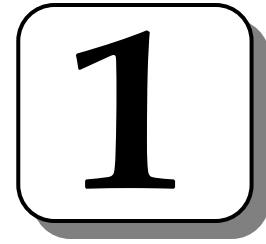


**Theory of Set**



This unit aims at explaining the set theory. Under the set theory, the topics covered are nature of set, types of sets, Venn diagram, basic set operations. Ample examples have been given in the lessons to demonstrate the application of set theory in practical contexts.

Blank Page

## Lesson-1: Meaning, Methods and Types of Set

After studying this lesson, you should be able to:

- Identify sets and its elements;
- Apply the methods of describing a sets;
- Define and explain different types of sets.

### Introduction

Mathematics speaks in the language of sets because it lies at the foundations of mathematics. Set is an undefined term, just as point and line are undefined in geometry.

### Meaning of Sets and Element

A set is understood to be a collection of objects. In other way, a set is a collection of definite and well distinguished objects. Each object belonging to a set is known as an element of the set.

*A set is a collection of definite and well distinguished objects.*

Generally capital letters  $A, B, C, X, Y...$ etc. are used to denote a set and small letters  $a, b, c, x, y, ...$ etc are used to denote elements of a set.

A set may be described by listing its members/elements between the symbols  $\{$  and  $\}$ , which are called set braces. Thus, the expression  $\{1, 2, 3, 4\}$  is read as: The set of 1, 2, 3 and 4. The elements of the set are 1, 2, 3 and 4. The symbol for set elements is  $\in$ . Thus  $1 \in \{1, 2, 3, 4\}$  is read as: 1 is an element of  $\{1, 2, 3, 4\}$ . The symbol  $\notin$  is the negation of  $\in$ . Thus  $6 \notin \{1, 2, 3, 4\}$  is read as: 6 is not an element of  $\{1, 2, 3, 4\}$ .

### Methods of Describing a Set

A set can be described in the following two ways:

**(1) Tabular Method:** In this method, all the elements of the set are enclosed by set braces. For example,

*All the elements of a set are enclosed by braces.*

- (a) A set of vowels;  $A = \{a, e, i, o, u\}$
- (b) A set of even numbers;  $A = \{2, 4, 6, \dots\}$
- (c) A set of first five letters of alphabet;  $A = \{a, b, c, d, e\}$
- (d) A set of odd numbers between 10 and 20;  $A = \{11, 13, 15, 17, 19\}$

**(2) Selector / Set-builder Notation Method:** In this method, elements of the set can be described on the basis of specific characteristics of the elements. For example, let if  $x$  is the element of a set, then the above four sets can be expressed in the following way:

*Elements of the set can be described on the basis of specific characteristics of the elements.*

- (a)  $A = \{x \mid x \text{ is a vowel of English alphabet}\}$
- (b)  $A = \{x \mid x \text{ is an even number}\}$
- (c)  $A = \{x \mid x \text{ is a letter of the first five alphabet in English}\}$
- (d)  $A = \{x \mid x \text{ is an odd number between 10 and 20}\}$

In this case, the vertical line “ $\mid$ ” after  $x$  is to be read as “such that”.

### Types of Sets

A set can be classified on the basis of special features of elements. There are different types of sets which are discussed below:

(i) **Null, Empty or Void Set:** A set having no element is known as null, empty or void set. It is denoted by  $\emptyset$ . For example,

(i)  $A = \{x \mid x \text{ is an odd integers divisible by } 2\}$

(ii)  $A = \{x \mid x^2 = 4, x \text{ is odd}\}$

A is the empty set in the above two cases.

(ii) **Finite Set:** A set is finite if it consists of a specific number of different elements, i.e. the counting process of the different members/elements of the set can come to an end. For examples,

(i)  $A = \{1, 2, 3, 4, 5\}$                       (ii)  $A = \{a, e, i, o, u\}$

then the sets are finite, because the elements can be counted by a finite number.

(iii) **Infinite Set:** If the elements of a set cannot be counted in a finite number, the set is called an infinite set. For example,

(a) Let  $A = \{1, 2, 3, 4, \dots\}$

(b) Let  $A = \{x \mid x \text{ is a positive integer divisible by } 5\}$ ,

then the sets are infinite, as the process of counting the elements of these sets would be endless.

(iv) **Sub Sets:** If every element in a set A is also the element of a set B, then A is called a subset of B. We denote the relationship by writing  $A \subseteq B$ , which can also be read as “A is contained in B.” For example,

$A = \{1, 2, 3, 4, \dots\}$

$B = \{x \mid x \text{ is a positive even number}\}$

$C = \{x \mid x \text{ is a positive odd number}\}$

In this case  $B \subseteq A$  and  $C \subseteq A$ , because all the positive even and odd numbers are included in the set A.

(v) **Proper subset:** Since every set A is a subset of itself, we call B is a proper subset of A if B is a subset of A and B is not equal to A. If B is a proper subset of A, it can be represented symbolically as  $B \subset A$ . For example,

$A = \{a, b, c, d\}$ ,                       $B = \{a, c, b, d, c, a\}$

$C = \{a, c, d, a, d, a\}$

In this case,  $C \subset A$  and  $C \subset B$ , because the elements of C set are included in the sets A and B, but the element ‘b’ in of A and B sets is not element of C set.

(vi) **Equal sets:** Two sets A and B are said to be equal if every element which belongs to A also belongs to B, and if every element which belongs to B, also belongs to A. We denote the equality of sets A and B by ‘ $A = B$ ’. For example, let  $A = \{2, 3, 4\}$ ,  $B = \{4, 2, 3\}$ ,  $C = \{2, 2, 3, 4\}$ , then  $A = B = C$ , since each element which belongs to any one of the sets also belongs to the other two sets.

A set is finite if it consists of a specific number of different elements.

Every element in a set A is also the element of a set B, then A is called a subset of B.

If the elements of one set can be put into one to one correspondence with the elements of another set, then the two sets are called

**(vii) Equivalent sets:** If the elements of one set can be put into one to one correspondence with the elements of another set, then the two sets are called equivalent sets. For example,

Let  $A = \{a, b, c, d, e, f\}$  and  $B = \{1, 2, 3, 4, 5, 6\}$

In this case, the elements of set A can be put into one to one correspondence with those of set B. Hence the two sets are equivalent. It is denoted by  $A \equiv B$ .

**(viii) Unit set/ singleton:** A set containing only one element is called a unit set or singleton. For example,

(a)  $A = \{a\}$

(b)  $B = \{x \mid x \text{ is a number between 27 and 34 divisible by 10}\}$

In B set, 30 is the only number between 27 and 34 which is divisible by 10.

**(ix) Power set:** The set of all the subsets of a given set A is called the power set of A. We denote the power set of A by  $P(A)$ . The power set is denoted by the fact that 'if A has  $n$  elements then its power set  $P(A)$  contains exactly  $2^n$  elements'.

For example, let  $A = \{a, b, c\}$  then its subset are  $\{a\}, \{b\}, \{c\}, \{a,b\}, \{b,c\}, \{c,a\}, \{a,b,c\}, \{\emptyset\}$

$\therefore P(A) = [\{a\}, \{b\}, \{c\}, \{a,b\}, \{b,c\}, \{c,a\}, \{a,b,c\}, \{\emptyset\}]$

**(x) Disjoint sets:** If the sets A and B have no element in common, i.e., if no element of A is in B and no element of B is in A, then we say that A and B are disjoint.

For example, let  $A = \{3, 4, 5\}$  and  $B = \{8, 9, 10, 11\}$ , then A and B sets are disjoint because there is no element common in these two sets.

**(xi) Universal sets:** Usually, only certain objects are under discussion at one time. The universal set is the set of all objects under discussion. It is denoted by U or I. For example, in human population studies, the universal set consists of all the people in the world.

The universal set is the set of all objects under discussion.

### Questions for Review

These questions are designed to help you assess how far you have understood and can apply the learning you have accomplished by answering (in written form) the following questions:

1. How would you define set? Identify some of the characteristics of sets. Is there any distinction between set and element?
2. Define the following with examples:  
Null set, finite set, infinite set, disjoint set, equal sets, equivalent sets, venn diagram, universal set.
3. (a) What is a subset and proper subset.  
(b) Find the power set of  $A = \{1, 2, 3, 4\}$
4. List the elements of the following sets:  
(a) The set of all integers whose squares are less than 30;  
(b) The set of integers satisfying the equation  $x^2 - 7x + 10 = 0$ ;  
(c) The set of all positive integers which are divisible by 5 and smaller than 78.
5. State whether each of the following sets is finite or infinite. When the set is finite indicate the number of elements it possesses;  
(a) The set of odd positive integers;  
(b) The set of all integers, whose squares are less than 45,  
(c) The set of integers satisfying the equation  $x^2 - 5x + 6 = 0$   
(d) The set of students in your class who are taller than 7 feet.

### Multiple Choice Questions (✓ the appropriate answer)

1. A set is:  
(a) a collection of objects  
(b) a group of objects  
(c) a well defined collection of objects.
2. If  $A = \{2\}$ , which of the following statements is correct?  
(a)  $A = 2$       (b)  $2 \in A$       (c)  $\{2\} \in A$ .
3. The total number of elements in the power set of a set A containing 7 elements is:  
(a) 64      (b) 49      (c) 128
4. The number of all possible proper subsets of  $\{2, 3, 5\}$  is  
(a) 3      (b) 7      (c) 8.
5. Which one of the following is a finite set?  
(a)  $\{x : x = y^2, y > 3\}$   
(b)  $\{x : x = 2y, 30 < y < 40\}$   
(c)  $\{x : x = y^3\}$
6. Which of the following pairs of sets is disjoint?

*School of Business*

- (a)  $\{0, 1, 2\}$  and  $\{0, -1, -2\}$
- (b)  $\{1, 3, 4, 5\}$  and  $\{3, 5, 7\}$
- (c)  $\{1, 2, 3\}$  and  $\{-1, -2, -3\}$



## Lesson-2: Venn Diagrams

After studying this lesson, you should be able to:

- Draw a Venn diagram of any set;
- Explain the nature of Venn diagram;
- Apply laws of sets for set operations;
- Explain the relationship between sets by using Venn diagram.

### Venn Diagrams

Generally Venn diagram is used to help visualize any set and the relationship between sets. It is usually bounded by a circle. With the help of Venn diagram we can easily illustrate various set operations.

Following is the Venn diagram (Fig.1) of three sets A, B and C:

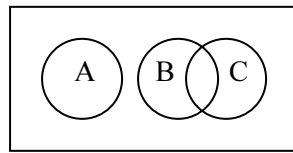


Fig.1

### Laws of Algebra of Sets

Basic set operations viz. union, intersection and complement satisfy some laws, known as Laws of Algebra of Sets. We state below these laws of algebra of sets:

- 1. Idempotent Laws:** For any set A, we have (i)  $A \cup A = A$ , (ii)  $A \cap A = A$ .
- 2. Commutative Laws:** For any two sets A and B, we have (i)  $A \cup B = B \cup A$ , (ii)  $A \cap B = B \cap A$ .
- 3. Associative Laws:** For any three sets A, B and C, we have, (i)  $A \cup (B \cup C) = (A \cup B) \cup C$ , (ii)  $A \cap (B \cap C) = (A \cap B) \cap C$ .
- 4. Distributive Laws:** (i)  $A \cup (B \cap C) = (A \cup B) \cap (A \cup C)$ , (ii)  $A \cap (B \cup C) = (A \cap B) \cup (A \cap C)$ .
- 5. De Morgan's Laws:** For any two sets A and B, we have (i)  $(A \cup B)^c = A^c \cap B^c$ , (ii)  $(A \cap B)^c = (A^c \cup B^c)$
- 6. Identity Laws:** Let U be the universal set,  $\phi$  be the null set and A be any subset of U. Then, (i)  $A \cup U = U$ , (ii)  $A \cap U = A$ , (iii)  $A \cup \phi = A$ , (iv)  $A \cap \phi = \phi$ .
- 7. Complement Law :** with the same notation given in (6) above, we have (i)  $A \cup A^c = U$ , (ii)  $(A \cup U)^c = \phi$ , (iii)  $(A^c)^c = A$ , (iv)  $U^c = \phi$ , (v)  $\phi^c = U$ , where  $A^c$  is the complement of A.

**Note:** We observe similarity in some laws of the set theory with the ordinary algebraic laws of real numbers. If  $a, b, c$  are real numbers, we have following laws of algebra of numbers:

- (i)  $a + b = b + a$ ,
- (ii)  $a \times b = b \times a$ ,
- (iii)  $a + (b + c) = (a + b) + c$

Basic set operations viz. union, intersection and complement satisfy some laws, known as Laws of Algebra of Sets.

Addition (+) and multiplication ( $\times$ ) notations of algebra of real numbers are replaced respectively by union ( $\cup$ ) and intersection ( $\cap$ ).

$$(iv) \quad a \times (b \times c) = (a \times b) \times c$$

$$(v) \quad a \times (b + c) = a \times b + a \times c.$$

If addition (+) and multiplication (×) notations of algebra of real numbers are replaced respectively by union (∪) and intersection (∩) notations of the set theory and the real numbers  $a, b, c$  are also replaced by the sets A, B, and C respectively, we obtain the following laws of algebra of sets:

$$(i) \quad A \cup B = B \cup A$$

$$(ii) \quad A \cap B = B \cap A$$

$$(iii) \quad A \cup (B \cap C) = (A \cup B) \cap C$$

$$(iv) \quad A \cap (B \cup C) = (A \cap B) \cup C$$

$$(v) \quad A \cap (B \cup C) = (A \cap B) \cup (A \cap C).$$

Some laws of algebra of sets differ from algebra of real numbers.

But some laws of algebra of sets differ from algebra of real numbers. For example, in ordinary algebra of real numbers, we have, (i)  $a + a = 2a$ , (ii)  $a \times a = a^2$ . But in algebra of sets, we have, (i)  $A \cup A = A$ , (ii)  $A \cap A = A$ .

In algebra of numbers, addition does not distribute across multiplication, i.e., for three real numbers  $a, b$  and  $c$ ,  $[a + (b \times c)] \neq (a + b) \times (a + c)$ .

But in algebra of sets, union distributes across intersection, i.e., for three sets A, B and C we have  $A \cup (B \cap C) = (A \cup B) \cap (A \cup C)$ .

**Example-1:**

Using Venn diagram, verify that  $A \cap (B \cap C) = (A \cap B) \cap C$

**Solution:**

**LHS:** Assume that the rectangular regions in Figs.-2, 3, 4 and 5 represent the universal set U and its subsets A, B and C in each diagram are represented by circular regions.

In Fig.-2, the set A has been shaded by horizontal straight lines and the set  $(B \cap C)$  has been shaded by vertical straight lines (i.e., the region common to both the sets B and C). Then by definition, the cross hatched region (i.e., the region where the horizontal and vertical lines intersect) represents the set  $A \cap (B \cap C)$ . The region representing this set has been shaded separately by slanting lines in Fig.-3.

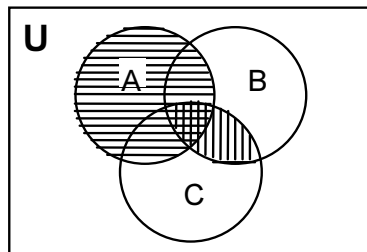


Fig. 2

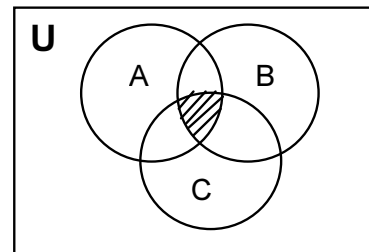
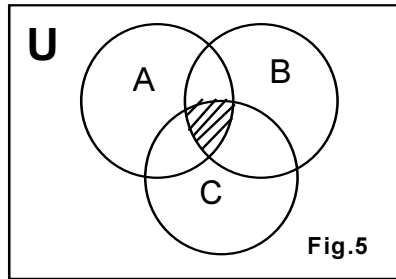
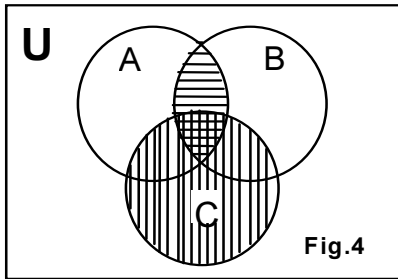


Fig. 3

**RHS:** In Fig.-4, the set  $(A \cap B)$  has been shaded by horizontal lines (i.e., the region common to both the sets A and B) and the set C has been shaded by vertical straight lines. Then by definition, the cross hatched region (i.e., the region where the horizontal and vertical lines intersect)

represents the set  $(A \cap B) \cap C$ . The region representing this set has been shaded separately by slanting lines in Fig.-5.



From Figs.-3 and 5, we see that the regions representing the sets  $[A \cap (B \cap C)]$  and  $[(A \cap B) \cap C]$  are identical. This verifies that  $A \cap (B \cap C) = (A \cap B) \cap C$ .

**Example-2:**

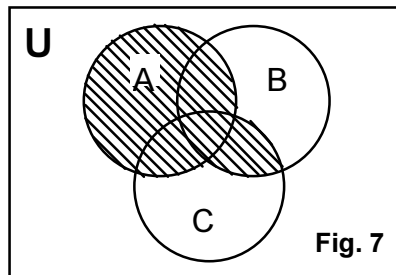
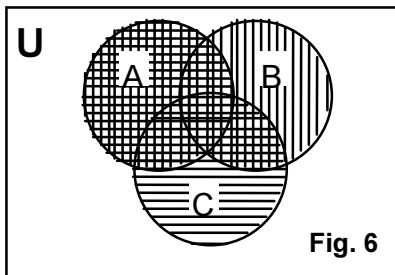
Using Venn diagram, verify that  $A \cup (B \cap C) = (A \cup B) \cap (A \cup C)$

**Solution:**

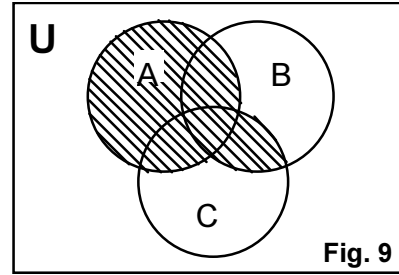
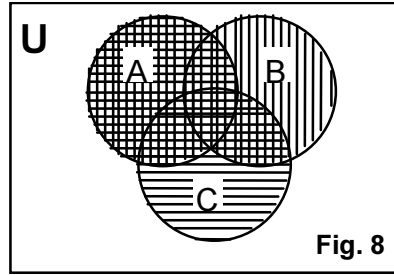
**LHS:** Assume that the rectangular regions in Figs.-6, 7, 8 and 9 represent the universal set U and its subsets A, B and C in each diagram are represented by circular regions.

In Fig.-6, the set A has been shaded by cross of horizontal and vertical lines. Set C has been shaded by horizontal straight lines and the set B has been shaded by vertical straight lines (i.e., the region common to both the sets B and C becomes a cross hatched region). Then by definition, the total cross hatched region represents the set  $A \cup (B \cap C)$ .

The region representing this set has been shaded separately by slanting straight lines in Fig.-7.



**RHS:** In Fig.-8, the set  $(A \cup B)$  has been shaded by vertical straight lines (i.e., the total region enclosed by the sets A and B) and the set  $(A \cup C)$  has been shaded by horizontal straight lines (i.e., the total region enclosed by the sets A and C). Then by definition, the cross hatched region (i.e., the region where the horizontal and vertical lines intersect) represents the set  $(A \cup B) \cap (A \cup C)$ . The region representing this set has been shaded separately by slanting lines in Fig.-7.



From Figs.-7 and 9, we see that the regions representing the sets  $A \cup (B \cap C)$  and  $(A \cup B) \cap (A \cup C)$  are identical. This verifies that  $A \cup (B \cap C) = (A \cup B) \cap (A \cup C)$ .

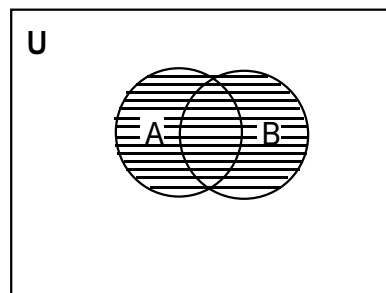
**Example-3: [De Morgan’s Laws]**

Using Venn diagrams, verify that  $(A \cap B)^c = A^c \cap B^c$

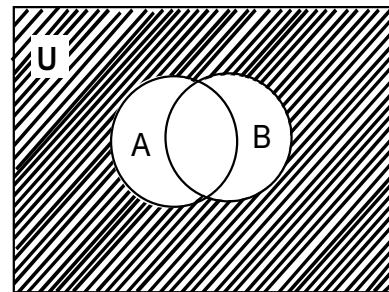
**Solution:**

**LHS:** Assume that the rectangular regions in Figs.-10, 11, 12 and 13 represent the universal set U and its subsets A and B in each diagram are represented by circular regions.

In Fig.-10, the set  $A \cup B$  has been shaded by horizontal straight lines (i.e., the total region enclosed by the sets A and B). Then by definition, the region of the rectangle outside the shaded region represents the set  $(A \cap B)^c$  (i.e. the complement of  $A \cup B$ ). The region represented by  $(A \cap B)^c$  has been shaded separately by slanting lines in Fig.-11.

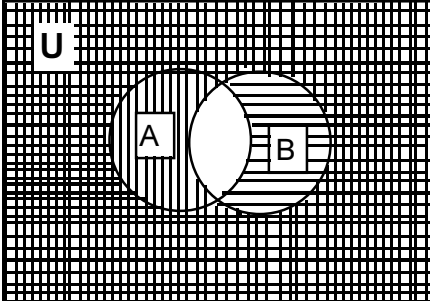


**Fig.10**

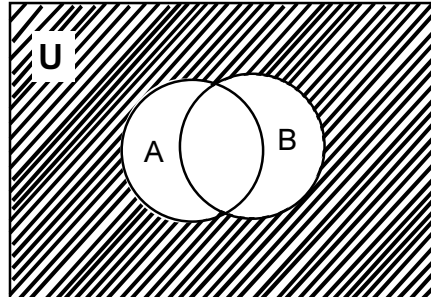


**Fig.11**

**RHS:** In Fig.-12, the set  $A^c$  has been shaded by horizontal straight lines (i.e., the region of the rectangle outside the set A) and the set  $B^c$  has been shaded by vertical straight lines (i.e., the region of the rectangle outside the set B). Then by definition, the cross hatched region (i.e., the region where the horizontal and vertical lines intersect) represents the set  $A^c \cap B^c$ . The region represented by the set  $A^c \cap B^c$  has been shaded separately by slanting lines in Fig.-13.



**Fig.12**



**Fig.13**

From Figs.-11 and 13, we see that the region representing the sets  $(A \cup B)^c$  and  $A^c \cap B^c$  are identical. This verifies that  $(A \cup B)^c = A^c \cap B^c$

### Questions for Review

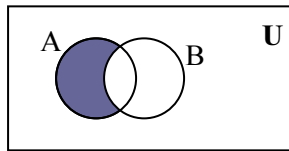
These questions are designed to help you assess how far you have understood and can apply the learning you have accomplished by answering (in written form) the following questions:

1. What are the laws of algebra in set theory?
2. Using Venn diagram verify that  $A \cup (B \cap C) = (A \cup B) \cap (A \cup C)$
3. Prove that  $A \cup (B \cap C) = (A \cup B) \cap (A \cup C)$  using Venn diagram.
4. Prove that  $(A \cap B)^c = A^c \cup B^c$  using Venn diagram.
5. Using Venn diagram show that  $X \cup (Y \cap Z) = (X \cup Y) \cap (X \cup Z)$

### Multiple Choice Questions (✓ the appropriate answer)

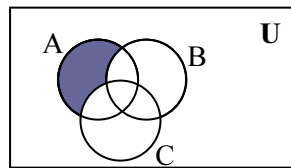
1. The shaded region in the adjoining diagram is:

- (a)  $A - B$       (b)  $B - A$       (c)  $A^c$



2. The shaded region in the adjoining diagram is:

- (a)  $A \cap (B \cup C)$       (b)  $A - (B \cup C)$       (c)  $A \cap (B - C)$



### Lesson-3: Addition, Subtraction and Complement of Sets

After studying this lesson, you should be able to:

- Apply the addition operation of sets;
- Apply the subtraction operation of sets;
- Apply the complement operation of sets.

#### Introduction

Basic set operations will help the mathematician in identifying common elements or uncommon elements or differences of elements between two or more sets. It has been discussed as under:

#### Union of Sets

The union of sets  $X$  and  $Y$  is the set of all elements, which belong to  $X$  or to  $Y$  or to both. We denote the union of  $X$  and  $Y$  by  $(X \cup Y)$ , which is read as ‘ $X$  union  $Y$ ’. The union of  $X$  and  $Y$  may also be defined concisely by,  $X \cup Y = \{x : x \in X \text{ or } Y\}$

union of sets  $X$  and  $Y$  is the set of all elements, which belong to  $X$  or to  $Y$  or to both.

#### Example-1:

Let  $X = \{1, 2, 3, 4, 5, 6\}$  and  $Y = \{3, 4, 5, 6, 7, 8\}$

then  $X \cup Y = \{1, 2, 3, 4, 5, 6, 7, 8\}$  ( According to the tabular method)

$X \cup Y = \{a : a \in I \text{ and } 1 \leq a \leq 8\}$  ( According to selector method).

#### Properties

The important properties of the union of two or more sets are:

- The individual sets composing a union are elements/ members of the union, In other words  $X \subseteq (X \cup Y)$  and  $Y \subseteq (X \cup Y)$
- It has an identity property in an empty/null set.  $\therefore X \cup \emptyset = X$ , for every set  $X$ .
- Union of a set with itself is the set itself, i.e.,  $X \cup X = X$ , for every set  $X$ .
- It has a commutative property, i.e., for any two sets  $X$  and  $Y$ ,  $X \cup Y = Y \cup X$
- It has an associative property, i.e., for any three sets  $X$ ,  $Y$  and  $Z$ ,
 
$$(X \cup Y) \cup Z = X \cup (Y \cup Z)$$
- If  $Y \subseteq X$ , then  $X \cup Y = X$  and if  $x \subseteq y$ , then  $X \cup Y = Y$ .
- $X \cup Y = \emptyset$ , then  $X = \emptyset$  and  $Y = \emptyset$ , in other words, both are null sets.
- $X \cap Y$  is the proper subset of  $X$  and  $X$  is the proper subset of  $X \cup Y$ . i.e.,  $(X \cap Y) \subset X \subset (X \cup Y)$ .

#### Intersection of Sets:

The intersection of sets  $X$  and  $Y$  is the set of elements, which are common to  $X$  and  $Y$ , that is, those elements which belong to  $X$  and

intersection of sets  $X$  and  $Y$  is the set of elements, which are common to  $X$  and  $Y$ .

which also belong to Y. We denote the intersection of X and Y by  $X \cap Y$ , which is read as 'X intersection Y'.

The intersection of X and Y may also be defined concisely by  $X \cap Y = \{b : b \in X, b \in y\}$

**Example-2:**

Let  $X = \{2, 3, 4, 5, 6, 7\}$  and  $Y = \{3, 4, 5, 6, 7, 8, 9\}$

Then  $X \cap Y = \{3, 4, 5, 6, 7\}$  (According to tabular method)

$X \cap Y = \{b : b \in I \text{ and } 3 \leq b \leq 7\}$  (According to selector method)

**Properties**

The important characteristics of intersection of sets are as follows:

- $X \cap Y$  is the subset of both the set X and the set Y,  
i.e.  $(X \cap Y) \subseteq X$  and  $(X \cap Y) \subseteq Y$ .
- Intersection of any set with an empty set is the null set, i.e.,  $X \cap \emptyset = \emptyset$  for every set X.
- Intersection of a set with itself is the set itself, i.e.  $(X \cap X) = X$ , for every set X.
- Intersection has commutative property, i.e.,  $X \cap Y = Y \cap X$ .
- Intersection has associative property. For any three sets X, Y and Z,  
 $(X \cap Y) \cap Z = X \cap (Y \cap Z)$
- If  $X \subseteq Y$ , then  $X \cap Y = X$  and  $Y \subseteq X$ , then  $X \cap Y = Y$ . For example, if  $X = \{2, 3\}$  and  $Y = \{2, 3, 4, 5, 6\}$ , then X is the subset of Y, i.e.,  $X \subseteq Y$ . In this case  $X \cap Y = \{2, 3\}$ , because 2 and 3 are the common elements of X and Y sets. Therefore,  $X \cap Y = X$ .
- If  $X \subseteq Y$  and  $Y \subseteq Z$  then  $X \subseteq (Y \cap Z)$ ; because  $Y \subseteq Z$  then  $Y \cap Z = Y$  :

**Distributive Laws of Unions and Intersections of Sets**

The distributive laws of unions and intersections of the sets can be illustrated as under:

- (i) The laws of the algebra of sets mentioned that the union distributes over intersection which is not possible in ordinary algebra,

$$\text{i.e., } X \cup (Y \cap Z) = (X \cup Y) \cap (X \cup Z)$$

Let  $X = \{a, b, c, d, e\}$ ;  $Y = \{c, d, e, f, g\}$  and  $Z = \{e, f, g, h, i\}$

then  $(Y \cap Z) = \{e, f, g\}$  and  $X \cup (Y \cap Z) = \{a, b, c, d, e, f, g\}$

On the other side,  $X \cup Y = \{a, b, c, d, e, f, g\}$ ;  $X \cup Z = \{a, b, c, d, e, f, g, h, i\}$

then  $(X \cup Y) \cap (X \cup Z) = \{a, b, c, d, e, f, g\}$

So,  $X \cup (Y \cap Z) = (X \cup Y) \cap (X \cup Z)$

- (ii) The algebra of sets can be expressed that the intersection distribute over the union which is also there in ordinary algebra. i.e.,  $X \cap (Y \cup Z) = (X \cap Y) \cup (X \cap Z)$ .

Let  $X = \{1, 2, 3, 4\}$ ,  $Y = \{2, 3, 4, 5\}$  and  $Z = \{3, 4, 5, 6\}$



Then  $(Y \cap Z) = \{2, 3, 4, 5, 6\}$  and

$$X \cap (Y \cup Z) = \{2, 3, 4\}$$

On the other hand,

$$(X \cup Y) = \{2, 3, 4\}; (X \cap Z) = \{3, 4\}$$

$$\therefore (X \cap Y) \cup (X \cap Z) = \{2, 3, 4\}$$

$$\text{So, } X \cap (Y \cup Z) = (X \cap Y) \cup (X \cap Z)$$

### Complement of a Set

The complement of a set  $X$  is the set of elements which do not belong to  $X$ , that is, the difference of the universal set  $U$  and  $X$ . We denote the complement of  $X$  by  $X^C$  or  $X'$ . The complement of  $X$  may also be defined concisely by,  $X^C = U - X = \{x : x \in U, x \notin X\}$ .

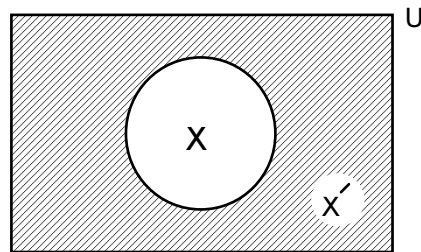
*The complement of a set  $X$  is the set of elements which do not belong to  $X$*

#### Example-3:

Let  $U = \{1, 2, 3, 4, 5, 6, 7\}$  and  $X = \{2, 3, 4, 5\}$

Then  $X^C = U - X = \{1, 6, 7\}$

The following Venn diagram showing the complement of a set:



The shaded region is  $X^C$  or  $X' = (U - X)$

### Properties

The important properties of complement of a set are:

- The intersection of a set  $X$  and its complement  $X'$  is a null set, i.e.,  $X \cap X' = \emptyset$ .
- The union of a set  $X$  and its complement  $X'$  is the universal set, i.e.,  $X \cup X' = U$ .
- The complement of the universal set is the empty set and the complement of the empty set is the universal set. Symbolically,  $U' = \emptyset$  and  $\emptyset' = U$ .
- The complement of the complement of a set is the set itself. Symbolically,  $(X')' = X$ .
- If  $X$  is the proper subset of  $Y$ , then the complement of  $Y$  set is the proper subset of complement of  $X$  set. Symbolically, if  $X \subset Y$ , then  $Y' \subset X'$ .

- Expansion or contraction of sets is possible by taking into account the complements of a set. For example,  $(X \cap Y) \cup (X \cap Y') = X$ , and  $(X \cup Y) \cap (X \cup Y') = X$ .

**Example-4:**

Let  $A = \{1, 2, 3, 4\}$ ,  $B = \{2, 4, 6, 8\}$  and  $C = \{3, 4, 5, 6\}$ . Find (i)  $A \cup B$ , (ii)  $A \cup C$ , (iii)  $B \cup C$ , (iv)  $B \cup B$ , (v)  $(A \cup B) \cup C$ , (vi)  $A \cup (B \cup C)$ .

**Solution:**

- (i)  $A \cup B = \{1, 2, 3, 4, 6, 8\}$
- (ii)  $A \cup C = \{1, 2, 3, 4, 5, 6\}$
- (iii)  $B \cup C = \{2, 3, 4, 5, 6, 8\}$
- (iv)  $B \cup B = \{2, 4, 6, 8\}$
- (v)  $(A \cup B) \cup C = \{1, 2, 3, 4, 5, 6, 8\}$
- (vi)  $A \cup (B \cup C) = \{1, 2, 3, 4, 5, 6, 8\}$

**Example-5:**

Let  $A = \{2, 3, 4, 5\}$ ,  $B = \{3, 5, 7, 8\}$  and  $C = \{4, 5, 6, 7, 8\}$

Find (i)  $A \cap B$ , (ii)  $A \cap C$ , (iii)  $B \cap C$ , (iv)  $B \cap B$ , (v)  $(A \cap B) \cap C$ , (vi)  $A \cap (B \cap C)$ .

**Solution:**

- (i)  $A \cap B = \{3, 5\}$
- (ii)  $A \cap C = \{4, 5\}$
- (iii)  $B \cap C = \{5, 7, 8\}$ .
- (iv)  $B \cap B = \{3, 5, 7, 8\}$
- (v)  $(A \cap B) \cap C = \{5\}$
- (vi)  $A \cap (B \cap C) = \{5\}$ .

**Example-6:**

Let  $A = \{1, 2, 3, 4\}$ ,  $B = \{2, 4, 6, 8\}$  and  $C = \{3, 4, 5, 6\}$ . Find (i)  $A - B$ ; (ii)  $C - A$ ; (iii)  $B - C$ ; (iv)  $B - A$ ; (v)  $B - B$ .

**Solution:**

- (i)  $A - B = \{1, 3\}$
- (ii)  $C - A = \{5, 6\}$
- (iii)  $B - C = \{2, 8\}$

(iv)  $B - A = \{6, 8\}$

(v)  $B - B = \{\phi\}$ .

### Questions for Review

These questions are designed to help you assess how far you have understood and can apply the learning you have accomplished by answering (in written form) the following questions:

1. Define the following with examples:  
(a) Union of sets, (b) Intersection of sets, and (c) Complement of a set.
2. Let the universal set and sets A, B and C are as follows:  
 $U = \{1, 2, 3, 4, 5, 6, 7, 8, 9, 10\}$   
 $A = \{1, 2, 3, 5\}$   
 $B = \{2, 5, 6, 8\}$   
 $C = \{5, 6, 8, 9, 10\}$   
Find (i)  $A \cup B \cup C$ ; (ii)  $(A \cup B \cup C)'$ ; (iii)  $A \cap B \cap C$ ; (iv)  $C'$ ; (v)  $B'$ ; (vi)  $A'$ .
3. Let  $U = \{0, 1, 2, 3, 4, 5, 6, 7, 8, 9\}$   
 $A = \{1, 2, 5, 7\}$ ,  $B = \{0, 1, 4, 6\}$ ,  $C = \{3, 4, 5, 7\}$   
Show that  $(A \cup B \cup C)' = A' \cap B' \cap C'$
4. If the universal set  $U = \{x : x \in \mathbb{N} \text{ and } 1 \leq x \leq 10\}$   
 $A = \{x : x \in \mathbb{N} \text{ and } 1 \leq x \leq 8\}$   
 $B = \{x : x \text{ is a natural number, which is less than 10 and divisible by 3}\}$   
 $C = \{1, 2, 3, 5, 6\}$   
Find (i)  $A'$ ; (ii)  $A \cup B$ ; (iii)  $A \cap C$ ; (iv)  $(A \cup C)'$ ; (v)  $B' \cap C$ .

### Multiple Choice Questions (✓ the appropriate answer)

1. If  $A = \{1, 2, 3, 4\}$  and  $B = \{5, 6\}$ , then  $A \cup B$  is  
(a)  $\{1, 2, 3, 4, 5, 6\}$  (b)  $\phi$ , (c)  $\{1, 2, 3, 4, 6\}$
2. Let  $A = \{0, 1, 3, 4\}$ ,  $B = \{5, 6, 1, 3, 9\}$  and  $C = \{0, 1, 2, 3, 9, 13\}$ .  
Then,  $(A \cap B) \cup C$  is :  
(a)  $\{0, 1, 3\}$  (b)  $\{0, 1, 2, 3, 9, 13\}$  (c)  $\{1, 3\}$
3. Let  $A = \{1, 2, 3, 4, 5\}$ ,  $B = \{2, 4, 6, 8\}$  and  $C = \{3, 4, 5, 6\}$  then,  
 $(A \cup B) \cap C$  is:  
(a)  $\{1, 2, 3, 4, 5, 6, 8\}$  (b)  $\{3, 4, 5, 6\}$  (c)  $\{3, 4\}$
4. Which of the following is a true statement?  
(a)  $(A \cup B)' = (A' \cup B')$   
(b)  $(A \cup B)' = A' \cap B'$   
(c)  $(A \cup B)' = A - B'$
5. If  $U = \{1, 2, 3, 4, 5, 6\}$ ;  $A = \{3, 5\}$ , then  $A'$  is equal to :  
(a)  $\{1, 2, 4, 6\}$  (b)  $\{3, 5, 6\}$  (c)  $\{1, 2, 3\}$

6. Let  $U = \{1, 2, 3, 4, 5, 6, 7, 8, 9, 10\}$  be the universal set and  $A = \{2, 4, 6\}$ ,  $B = \{1, 3, 7\}$ . Then  $A' \cap B'$  is equal to:
- (a)  $\{2, 4, 5, 6, 8, 9, 10\}$
  - (b)  $\{5, 8, 9, 10\}$
  - (c)  $\{1, 3, 5, 7, 8, 9, 10\}$

## Lesson-4: Difference and Product of Sets

After studying this lesson, you should be able to:

- State the difference of sets;
- State the product of sets;
- Explain the presentation of sets with corresponding set notation.

### Difference of Two Sets

The difference of set Y from set X is the set of elements, which belong to X but which do not belong to Y. We denote the difference of X and Y by  $(X \sim Y)$ , which is read as: X difference Y, or simply, 'X minus Y'. The difference of X and Y may also be defined concisely by,  $X \sim Y = \{a : a \in X, a \notin Y\}$ .

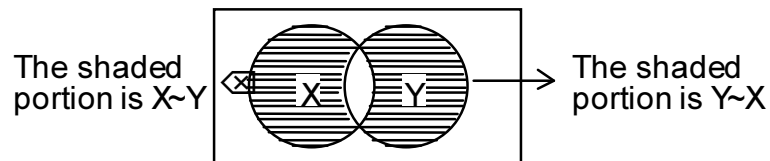
*The difference of set Y from set X is the set of elements, which belong to X but which do not belong to Y.*

For example: Let  $X = \{a, b, c, d, e, f\}$  and  $Y = \{d, e, f, g, h\}$

$$\text{Then } X \sim Y = \{a, b, c\}$$

$$\text{and } Y \sim X = \{g, h\}$$

The difference of two set can be shown by Venn diagram as under:



### Properties

The important properties of the difference of two sets are as under:

- $X - Y$  is the subset of X, i.e.,  $(X - Y) \subseteq X$  and  $(Y - X)$  is the subset of Y, i.e.,  $(Y - X) \subseteq Y$ .
- $(X - Y)$ ,  $(X \cap Y)$  and  $(Y - X)$  are mutually disjoint.
- $X - (X - Y) = (X \cap Y)$  and  $Y - (Y - X) = X \cap Y$ .

### Product of Two Sets

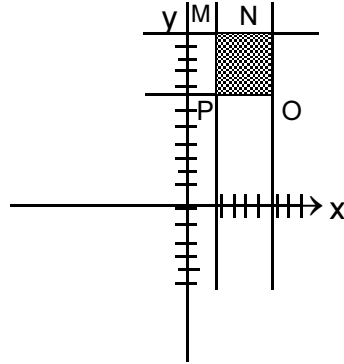
Let X and Y be two sets. The product of sets X and Y consists of all ordered pairs where  $\{(x, y) : x \in X \text{ and } y \in Y\}$ . It is denoted by  $(X \times Y)$ , which is read as "X cross Y". The product of sets X and Y may also be defined concisely by,  $(X \times Y) = \{(x, y) : x \in X, y \in Y\}$ .

*The product of sets X and Y consists of all ordered pairs where  $\{(x, y) : x \in X \text{ and } y \in Y\}$ .*

The product of sets  $(X \times Y)$  is also called Cartesian product of X and Y.

For example: Let  $X = \{1, 2, 3\}$  and  $Y = \{5, 6, 7\}$

Then  $X.Y = \{(1,5), (1,6), (1,7), (2,5), (2,6), (2,7), (3,5), (3,6), (3,7)\}$ . The Cartesian product of  $X$  and  $Y$  sets can be displayed in the following rectangular co-ordinate system.



The shaded portion is  $XY$  and  $MNOP$  is the required rectangular system of  $XY$ .

### Properties

The important properties of a Cartesian product are as follows:

- $X.Y$  and  $Y.X$  have the same number of elements but  $X.Y \neq Y.X$ , unless  $X = Y$ . Thus the Cartesian product of two sets is commutative if the two sets are equal.
- In the product of sets  $Y.X$ , the first component of ordered pairs are taken from  $Y$  and the second from  $X$ .
- If  $X$  and  $Y$  are disjoint sets, then  $X.Y$  and  $Y.X$  are also disjoint.
- If the set  $X$  consists of  $m$  elements  $x_1, x_2, \dots, x_m$  and set  $Y$  consists of the  $n$  elements  $y_1, y_2, y_3, \dots, y_n$  then the product sets  $X.Y$  consists of  $mn$  elements.
- If either  $X$  or  $Y$  is null then the set  $X.Y$  is also a null set.
- If either  $X$  or  $Y$  is infinite and the other is a non-empty set, then  $X.Y$  is also an infinite set.
- If  $X \subset Y$ , then  $X.Z \subset Y.Z$
- If  $X \subset Y$  and  $Z \subset D$ , then  $X.Z \subset Y.D$ .
- If  $X \subseteq Y$  then  $X.Y \Rightarrow (X.Y) \cap (Y.X)$
- If  $X, Y$  and  $Z$  be any three sets, then  $X.(Y \cap Z) = (X.Y) \cap (X.Z)$
- If  $X, Y$  and  $Z$  be any three sets, then  $X.(Y \cup Z) = (X.Y) \cup (X.Z)$
- $(X.Y) \cap (Z.D) = (X \cap Z) \times (Y \cap D)$ .

The following examples contain some model applications of set theory.

#### Example-1:

Let  $A = \{a, b\}$ ,  $B = \{2, 3\}$  and  $C = \{3, 4\}$ . Find (i)  $A \times (B \cup C)$ ; (ii)  $(A \times B) \cup (A \times C)$ ; (iii)  $A \times (B \cap C)$ ; (iv)  $(A \times B) \cap (A \times C)$ .

**Solution:**

- (i)  $A \times (B \cup C) = (a, b) \times (2, 3, 4)$   
 $= \{(a,2), (a,3), (a,4), (b,2), (b,3), (b,4)\}$
- (ii)  $(A \times B) \cup (A \times C)$   
 $(A \times B) = \{(a, b) \times (2, 3)\} = \{(a,2), (a,3), (b,2), (b,3)\}$   
 $(A \times C) = \{(a, b) \times (3, 4)\} = \{(a,3), (a,4), (b,3), (b,4)\}$   
 $(A \times B) \cup (A \times C) = \{(a,2), (a,3), (a,4), (b,2), (b,3), (b,4)\}$
- (iii)  $A \times (B \cap C) = \{(a, b) \times (3)\} = \{(a, 3), (b, 3)\}$
- (iv)  $(A \times B) \cap (A \times C) = \{(a, 3), (b, 3)\}$ .

**Example-2:**

Let R represent the set of all rational numbers and

$$X = \{x : x \in \mathbb{R} \text{ and } -4 \leq x < 3.5\}$$

$$Y = \{y : y \in \mathbb{R} \text{ and } 1.5 < y \leq 4.37\}$$

- (i) Express  $X \cup Y$  and  $X \cap Y$ .
- (ii) Draw a rectangular coordinate system and show XY on it.

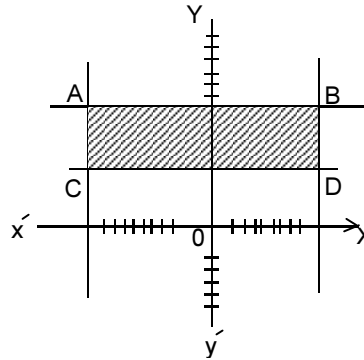
**Solution:**

$$(i) \quad X \cup Y = \{m : m \in \mathbb{R} \text{ and } -4 \leq m \leq 4.37\}$$

$$X \cap Y = \{m : m \in \mathbb{R} \text{ and } 1.5 < m < 3.5\}$$

$$(ii) \quad X.Y = \{(x,y) : x \in X, y \in Y, -4 \leq x < 3.5 \text{ and } 1.5 < y \leq 4.37\}$$

The following rectangular of coordinates shows X.Y in set notation.



So, the ABCD is the required rectangular coordinate system of X.Y.

**Example-3:**

Let R represent the set of all real number and.

$$X = \{x | x \in \mathbb{R} \text{ and } -1 \leq x < 2\}$$

$$Y = \{y | y \in \mathbb{R} \text{ and } 0 \leq y \leq 3\}$$

- (i) Draw a rectangular coordinate system and show X.Y on it.
- (ii) Draw another rectangular coordinate system and show Y.X on it.

**Solution:**

$$(i) \quad \text{Element of X set} = \{-1, 0, 1\}$$

$$\text{Element of Y set} = \{0, 1, 2, 3\}$$

In set notation:

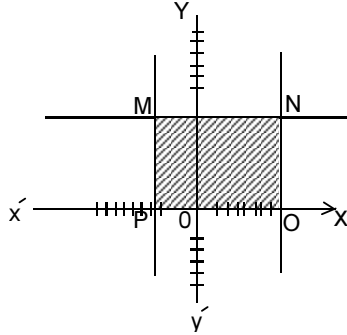


$$X.Y = \{(-1,0), (-1,1), (-1,2), (-1,3), (0,0), (0,1), (0,2), (0,3), (1,0), (1,1), (1,2), (1,3)\}$$

In expression:

$$X.Y = \{(x, y) \mid x \in X, y \in Y, -1 \leq x < 2 \text{ and } 0 \leq y < 3\}$$

The following rectangular of coordinates shows X.Y in set notation.



$\therefore$  MNOP is the required Rectangular system of X.Y.

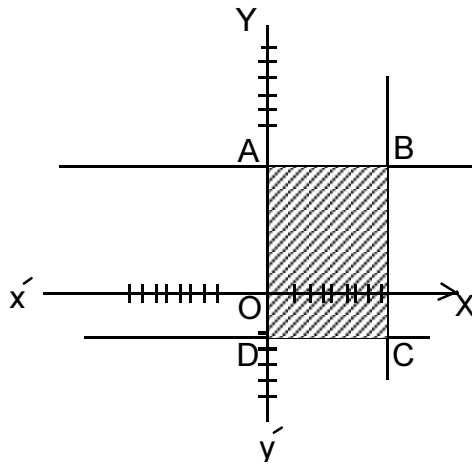
(ii) In set notation:

$$Y.X = \{(0,1), (0,0), (0,1), (1,-1), (1,0), (1,1), (2,-1), (2,0), (2,1), (3,-1), (3,0), (3,1)\}$$

In expression:

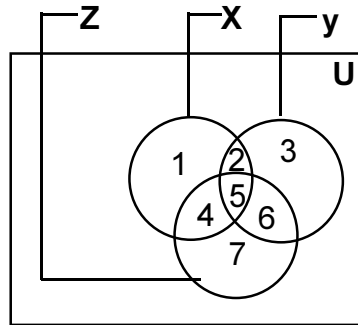
$$Y.X = \{(x, y) \mid x \in X, y \in Y, 0 \leq y \leq 3 \text{ and } -1 \leq x < 2\}$$

The following rectangular coordinate shows Y.X in expression.



So, ABCD is the required rectangular co-ordinate system of Y.X.

In the previous discussion we have learned about the union of sets, intersection of sets, complement of a set, difference of sets and product of two sets. Now the different parts of the three joint sets of X, Y and Z are expressed in mathematical way as under:



In the above Venn diagram,

- (1) indicates  $X \cap Y' \cap Z'$
- (2) indicates  $X \cap Y \cap Z'$
- (3) indicates  $X' \cap Y \cap Z'$
- (4) indicates  $X \cap Y' \cap Z$
- (5) indicates  $X \cap Y \cap Z$
- (6) indicates  $X' \cap Y \cap Z$
- (7) indicates  $X' \cap Y' \cap Z$
- (8) indicates  $X' \cap Y' \cap Z'$

### Questions for Review

These questions are designed to help you assess how far you have understood and can apply the learning you have accomplished by answering (in written form) the following questions:

- Define the following with examples:  
Product of two sets, Difference of two sets.
- Let the universal set,  $U = \{a, b, c, d, e, f, g\}$ ,  $X = \{a, b, c, d, e\}$   
 $Y = \{a, c, e, g\}$  and  $Z = \{b, e, f, g\}$   
Find (i)  $X \cup Z$ , (ii)  $Y \cap X$ , (iii)  $Z \sim Y$ , (iv)  $Y'$ , (v)  $X' - Y$ , (vi)  $Y' \cap Z$ , (vii)  $(X \sim Z)'$ , (viii)  $Z' \cap A$ , (ix)  $(X \sim Y)'$ , (x)  $(X \cap X)'$ .
- If  $M = \{1, 2, 3\}$ ,  $N = \{2, 3, 4\}$ ,  $O = \{1, 3, 4\}$  and  $P = \{2, 4, 5\}$ , Prove that  $(M \times N) \cap (O \times P) = (M \cap O) \times (N \cap P)$
- Let R represents the set of all rational numbers and  
 $X = \{x : x \in R \text{ and } -2 \leq x < 3.5\}$   
 $Y = \{y : y \in R \text{ and } 1.5 < y \leq 4.32\}$   
(i) Express  $X \cup Y$  and  $X \cap Y$ .  
(ii) Draw rectangular coordinate system and show (a)  $X.Y$ , and (b)  $Y.X$  on it.
- Given  $A = \{1, 3, 4, 7\}$ ;  $B = \{3, 7, 12\}$ ;  $C = \{1, 5, 8\}$   
Write the following sets:  
(i) The set containing all elements that are members of A or members of B or members of both A & B.  
(ii) The set of elements that are members of both A and B.  
(iii) The set of elements that are members of both B and C.  
(iv) The set of elements that are members of A but not members of B.  
(v) The set of elements that are members of all three sets.

### Multiple Choice Questions (✓ the appropriate answer)

- If  $A = \{1, 2, 3, 4, 5, 6, 7, 8, 9\}$ ,  $B = \{2, 4, 6, 7, 8\}$  and  $C = \{3, 4, 5, 8, 9, 10\}$ , then  $(A - B) \cup C$  is  
(a)  $\{1, 3, 4, 5, 8, 9, 10\}$   
(b)  $\{2, 4, 6, 7, 8\}$   
(c)  $\{1, 3, 4, 5, 8, 9\}$
- $A - (B \cup C)$  equals:  
(a)  $(A - B) \cup (A - C)$   
(b)  $(A \cap B) \cap (A - C)$   
(c)  $(A - B) \cup C$ .
- If  $U = \{x \in N : 1 \leq x \leq 10\}$ ,  $A = \{1, 2, 3, 4\}$ ,  $B = \{2, 3, 6, 10\}$  then  $(A - B)'$  is:  
(a)  $\{1, 4\}$                       (b)  $\{2, 3\}$                       (c)  $\{2, 3, 5, 6, 7, 8, 9, 10\}$
- $A \cap (B - C)$  is equal to:  
(a)  $(A \cap B) - (A \cap C)$   
(b)  $(A \cap B) - C$   
(c)  $(A \cap B) - (A \cup C)$

5. If  $A = \{2, 3, 5\}$ ,  $B = \{4, 5, 6\}$ , then  $(A \cap B) \times A$  is
- (a)  $\{2, 5\}, (3, 5)$
  - (b)  $\{(5, 2), (5, 3), (5, 5)\}$
  - (c)  $\{(5, 2), (2, 5), (3, 5)\}$
6. If a set A has 5 elements and a set B has 10 elements, then the number of elements in  $(A \times B)$  is:
- (a) 50
  - (b) 15
  - (c) 5.

## Lesson-5: Applications of Set Theory to Solve Business Problems

After studying this lesson, you should be able to:

- Explain the relationship of sets;
- Apply the principles of set theory in business problems.

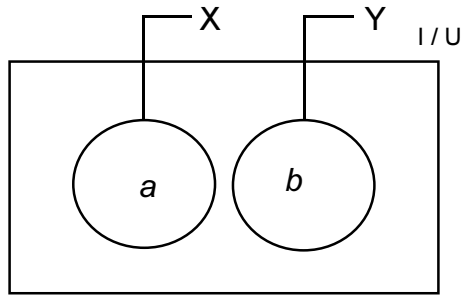
### Introduction

The numbers of elements in a set  $X$  is denoted by ' $n(X)$ '. Again, the number of elements in a set  $Y$  is expressed by  $n(Y)$ . Here we derive a formula for  $n(X \cup Y)$  in terms of  $n(X)$ ,  $n(Y)$  and  $n(X \cap Y)$ . First we observe that if  $X$  and  $Y$  set are disjoint, i.e., if  $(X \cap Y) = \emptyset$ , then  $n(X \cup Y) = n(X) + n(Y)$

union of two joint sets are  $n(X \cup Y) = n(X) + n(Y) - (X \cap Y)$ .

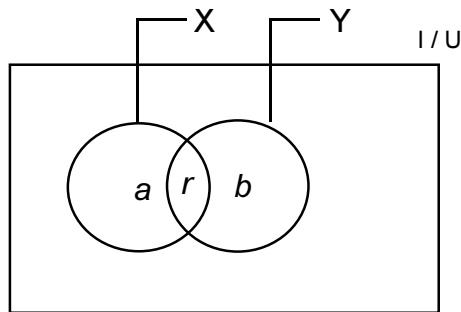
Later we take the case of the union of two finite sets which are not mutually disjoint, that is, there are some common elements between the two sets, i.e., the union of two joint sets are  $n(X \cup Y) = n(X) + n(Y) - (X \cap Y)$ .

The following Venn diagram presents two disjoint sets:



Here, the numbers of the elements of  $X$  set,  $n(X) = a$ , and  $Y$  set,  $n(Y) = b$ . If the sets are disjoint, then,  $n(X \cup Y) = (a + b) = n(X) + n(Y)$

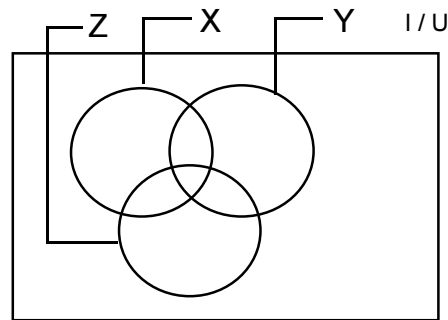
On the other hand, if ' $r$ ' is the common element of both the sets  $X$  and  $Y$ , the total elements of  $X$  set  $n(X) = a + r$  and  $Y$  set,  $n(Y) = b + r$ . i.e.,  $n(X \cup Y) = \{a, b, r\}$



But if  $n(X \cup Y) = n(X) + n(Y)$ , then the elements of  $n(X \cup Y)$  are  $\{(a + r) + (b + r)\} = \{a + b + r + r\}$ . Here the element ' $r$ ' will be deleted because it is added more than one time.

$$\text{i.e., } n(X \cup Y) = [\{a + r\} + \{b + r\} - r] = n(X) + n(Y) - n(X \cap Y)$$

Again for the union of any three sets X, Y and Z, which are mutually disjoint, we have,  $n(X \cup Y \cup Z) = n(X) + n(Y) + n(Z)$ . But when these three sets are joint, then the Venn diagram would be as under:



In the above diagram, the three sets are mutually joint. For the union of these three sets the elements are,  $n(X \cup Y \cup Z)$ .

Now, if we consider that X is a set and  $(Y \cup Z)$  is another set, then as per union of sets, we get:

$$\begin{aligned} n(X \cup Y \cup Z) &= n[X \cup (Y \cup Z)]. \\ &= n(X) + n(Y \cup Z) - n[X \cap (Y \cup Z)] \end{aligned}$$

Again  $n(Y \cup Z) = n(Y) + n(Z) - n(Y \cap Z)$

and  $n[X \cap (Y \cup Z)] = n[(X \cap Y) \cup (X \cap Z)]$  (using distributive law)

$$\begin{aligned} &= n(X \cap Y) + n(X \cap Z) - n[(X \cap Y) \cap (X \cap Z)] \\ &= n(X \cap Y) + n(X \cap Z) - n(X \cap Y \cap Z) \end{aligned}$$

Therefore

$$\begin{aligned} n(X \cup Y \cup Z) &= n(X) + n(Y) + n(Z) - n(X \cap Y) - n(Y \cap Z) - n(X \cap Z) \\ &\quad + n(X \cap Y \cap Z) \end{aligned}$$

Here,  $n(X) \Rightarrow$  The elements of X set

$n(Y) \Rightarrow$  The elements of Y set

$n(Z) \Rightarrow$  The elements of Z set

$n(X \cap Y) \Rightarrow$  The common elements of X and Y set.

$n(Y \cap Z) \Rightarrow$  The common elements of Y and Z set.

$n(X \cap Z) \Rightarrow$  The common elements of X and Z set.

$n(X \cap Y \cap Z) \Rightarrow$  The common elements of X, Y and Z set.

Now we have got an idea regarding the operation of set theory, which can be applied in the field of business.

The following section of this lesson contains some model applications of set theory.

### Example-1:

There are 1,500 students who appeared at the CMA examination under the ICMAB. Out of these students, 450 failed in Accounting, 500 failed in Business Mathematics and 475 failed in Costing. Those who failed in both Accounting and Business Mathematics were 300, those who failed

*The operation of set theory, which can be applied in the field of business.*

in both Business Mathematics and Costing were 320 and those who failed in both Accounting and Costing were 350. The students who failed in all the three subjects were 250.

- Find (i) How many students failed in at least any one of the subjects?  
 (ii) How many students failed in no subjects?  
 (iii) How many students failed in only one subjects?  
 (iv) How many students failed in both Accounting and Business Mathematics only?

**Solution:**

Let U is the set of the students who appeared at the CMA examination and A, B and C denote the set of students who failed in Accounting, Business Mathematics and Costing respectively. Now we are given,

$$\begin{aligned} n(U) &= 1500 & n(A \cap B) &= 300 \\ n(A) &= 450 & n(B \cap C) &= 320 \\ n(B) &= 500 & n(A \cap C) &= 350 \\ n(C) &= 475 & n(A \cap B \cap C) &= 250. \end{aligned}$$

- (i) Number of students who failed in at least any one of the subjects.

$$\begin{aligned} \text{Now, } n(A \cup B \cup C) &= n(A) + n(B) + n(C) - n(A \cap B) - n(B \cap C) - n(A \cap C) + n(A \cap B \cap C) \\ &= 450 + 500 + 475 - 300 - 320 - 350 + 250 \\ &= (1675 - 970) = 705 \end{aligned}$$

Therefore, the number of students who failed at least in any one of the subjects is 705.

- (ii) Number of students who failed in no subjects.

$$\begin{aligned} n(A \cap B \cap C)' &= n(U) - n(A \cup B \cup C) \\ &= (1500 - 705) = 795 \end{aligned}$$

Hence the numbers of students who failed in no subjects is 795

- (iii) Number of students who failed in only one subject:

$$\begin{aligned} \text{Now, } n(A \cap B' \cap C') &= n(A) - n(A \cap B) - n(A \cap C) + n(A \cap B \cap C) \\ &= (450 - 300 - 350 + 250) = 50 \end{aligned}$$

$$\begin{aligned} n(A' \cap B \cap C') &= n(B) - n(A \cap B) - n(B \cap C) + n(A \cap B \cap C) \\ &= (500 - 300 - 320 + 250) = 130 \end{aligned}$$

$$\begin{aligned} n(A' \cap B' \cap C) &= n(C) - n(A \cap C) - n(B \cap C) + n(A \cap B \cap C) \\ &= (475 - 350 - 320 + 250) = (725 - 670) = 55 \end{aligned}$$

Hence the number of students who failed in only one subject is,

$$n(A \cap B' \cap C') + n(A' \cap B \cap C) + n(A' \cap B' \cap C) \\ = (50 + 130 + 55) = 235.$$

(iv) Number of students who failed in both Accounting and Business mathematics only:

$$\text{Now, } n(A \cap B \cap C') = n(A \cap B) - n(A \cap B \cap C) \\ = (300 - 250) = 50$$

So the number of students who failed in both Accounting and Business Mathematics only is 50.

**Example-2:**

A Survey of 600 workers in a plant indicated that 410 owned their own houses, 500 owned cars, 550 owned televisions, 410 owned cars and televisions, 340 owned cars and houses, 370 owned houses and television and 300 owned all three. Illustrate by a Venn diagram and prove that the above data is not correct. What set is empty?

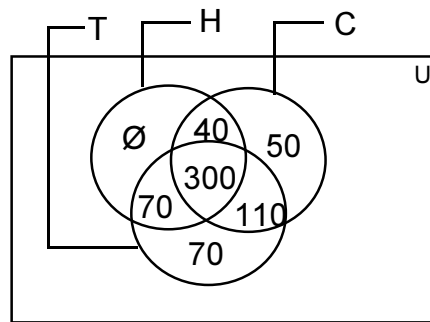
**Solution:**

Let U is the set of the workers who were surveyed and H, C and T are the sets of workers who owned their houses, cars and televisions respectively. Now we are given,

$$n(U) = 600; n(H) = 410; n(C) = 500; n(T) = 550; n(C \cap T) = 410;$$

$$n(H \cap T) = 370; n(C \cap H) = 340; n(C \cap H \cap T) = 300.$$

The following Venn diagram shows the result of the survey of ownership:



Hence, the total number of workers in the survey is,

$$n(H \cup C \cup T) = n(H) + n(C) + n(T) - n(H \cap C) - n(C \cap T) - n(H \cap T) \\ + n(H \cap C \cap T) \\ = (410 + 500 + 550 - 340 - 410 - 370 + 300) = 640$$

This figure exceeds the total number of workers who were surveyed. Hence the given data is not correct or consistent.



In Venn diagram,  $(H \cap C' \cap T')$  set is empty.

$$\begin{aligned} n(H \cap C' \cap T') &= n(H) - n(H \cap C) - n(H \cap T) + n(H \cap C \cap T) \\ &= (410 - 340 - 370 + 300) = (710 - 710) = \emptyset. \end{aligned}$$

**Example-3:**

Mr. Arefin has 165 workers in process-X, 110 workers in process-Y and 97 workers in process-Z in his firm. Out of these workers, 281 workers are skilled in the activities of X and/or Y, 269 workers are skilled in the activities of Y and/or Z, 241 workers are skilled in the activities of X and/or Z. However, 44 workers are unskilled.

Accounts department of his firm has informed that the average monthly earnings of different types of workers are as follows:

Workers who are skilled in the activities of at least two processes:  
Tk.3,500

Workers who are skilled in the activities of any one process: Tk.2,500

Workers who are not skilled: Tk.1,500

Find the monthly amount of total earnings of all workers of the firm.

**Solution:**

Let U is the set of the workers who are skilled in all the processes. X, Y and Z are the sets of workers who are skilled in Process-X, Process-Y and Process-Z respectively.

We are given,

$$\begin{aligned} n(X) &= 165; n(Y) = 110; n(Z) = 97; n(X \cup Y) = 281; n(Y \cup Z) = 269; \\ n(X \cup Z) &= 241. \end{aligned}$$

The numbers of workers who are not skilled is 44.

$$\begin{aligned} \text{Now, the total number of workers, } n(U) &= (P_x + P_y + P_z) = \\ &= (165+110+97) = 372 \end{aligned}$$

The total number of the workers who are skilled in at least one of the processes;

$$n(X \cup Y \cup Z) = (372 - 44) = 328$$

The number of workers who are skilled in only X,

$$n(X \cup Y \cup Z) - n(Y \cup Z) = (328 - 269) = 59$$

The number of workers who are skilled in only Y,

$$n(X \cup Y \cup Z) - n(X \cup Z) = (328 - 241) = 87$$

The number of workers who are skilled in only Z,

$$n(X \cup Y \cup Z) - n(X \cup Y) = (328 - 281) = 47$$

So, the total number of workers who are skilled in only one process,

*School of Business*

$$= (59 + 87 + 47) = 193.$$

Therefore the number of workers who are skilled in at least two processes is,

$$= (328 - 193) = 135.$$

Hence the monthly amount of total earnings of all workers of the firm is,

$$= 135.(3,500) + 193.(2,500) + 44.(1,500)$$

$$= (4,72,500 + 482,500 + 66,000) = \text{Tk.}10,21,000.$$

### Questions for Review

These questions are designed to help you assess how far you have understood and can apply the learning you have accomplished by answering (in written form) the following questions:

1. Prove that  $n(A \cup B \cup C) = n(A) + n(B) + n(C) - n(A \cap B) - n(B \cap C) - n(A \cap C) + n(A \cap B \cap C)$ .
2. In a survey, only 60% of 1000 questionnaires are found correct. Survey result indicates that only 42% prefer their present job responsibilities and 55% prefer their job environment. If 30% prefer both the job responsibility and job environment, how many do not prefer any one of these two?
3. In a survey of 100 families, the numbers that read the recent issues of various magazines were found to be as follows:  
  
Dhaka Courier 28; Readers Digest 30; Bangladesh Time 5; Courier and Readers Digest 8; Courier and Bangladesh Time 10. Readers Digest and Bangladesh Time 42; All the three magazines 3. With the help of set theory, find
  - (i) How many read none of the three magazines?
  - (ii) How many read Bangladesh Time as their only magazine?
  - (iii) How many read Reader's Digest if and only if they read Bangladesh Time?
4. The production manager of MIC House, M. Nuruddin has 95 workers in Division-P, 80 workers in Division-Q and 120 workers in Division-R in his firm. Three different types of products are produced in these three divisions and workers in each division can easily perform the activities of that division. However, out of these workers, 25 workers can perform the activities of P and/or Q, 32 workers can perform the activities of Q and/or R, 39 workers can perform the activities of P and/or R. There are only 12 workers who can perform any activity of the three divisions. Due to change in the demand of the product of three divisions, M. Nuruddin has to shift workers from one division to another. In a 40-hour week, what would be the maximum labor hours in each division that can be worked by this work force?

### Multiple Choice Questions (✓ the appropriate answer)

*School of Business*

1. In a group of persons, each one knows either Bengali or English. If 100 know Bengali, 50 know English and 30 know both, how many persons are there in the group?  
(a) 130,            (b) 120,            (c) 150
2. If 63% of Bangladeshi like milk and 76% like tea, how many like both?  
(a) 39%,            (b) 26%,            (c) 13%
3. In a group of 52 persons, 16 drink tea but not coffee and 33 drink tea. How many drink coffee but not tea?  
(a) 17,            (b) 3,            (c) 19
4. A dinner party is to be fixed for a group consisting of 100 persons. In this party, 50 persons do not prefer fish, 60 prefer chicken and 10 do not prefer either chicken or fish. The number of persons who prefer both fish and chicken is:  
(a) 30,            (b) 10,            (c) 20
5. In a class consisting of 100 students, 20 know English, 20 do not know Hindi and 10 know neither English nor Hindi. The number of students knowing both Hindi and English is:  
(a) 15,            (b) 20,            (c) 10