

# **Zj b1qj-K ik yv**

**Comparative Education**

**EDM 1106**

**Gg GW tcÖMg**

**~g Ae GWKkb**



**e1sj v` k D>gÿ vekte` `vj q**

# **Zj bvgj-K ikjv**

EDM 1106

## **iPbvq**

**cđmi tgv: Zevik Dj Bmjvg**

**~đ Ae GWžKkb, evDwe**

## **máúv`bvq**

**cđmi W. Gg G Ine ıgTv**

**~đ Ae GWžKkb, evDwe**

## **gıbv tvımb**

**mnıhvıx Aa`vcK, ~đ Ae GWžKkb, evDwe**

## **ımj bv Av<sup>3</sup>vi**

**mnKvix Aa`vcK, ~đ Ae GWžKkb, evDwe**

**~đ Ae GWžKkb**



**elsj vı`k Dıgıı vekıe``vj q**

# Zjbigj-K ikjv

EDM 1106

## Gg GW tcÜMg

### cKvkKvj

cÜg gÿY: Wtµ†, 2000

clj: gÿY: 2001, 2004, 2006, 2010

clj: gÿY: Ribgwi 2012

### cÜ`

KvRx mvBdžxb AveŸvm

### KvúDUvi KtúvR

tZvdvtqj Avnµš

© ejsj vt`k D>gÿ wekte`vj q

ISBN: 984-34-0048-8

### cKvkbiq

cKvkbi, gÿY I weZiY wefvM

ejsj vt`k D>gÿ wekte`vj q

MvRxcj- 1705|

### gÿY

ejsj vevRvi tch GÜ crevjj tKkb

53 b\_@K nj ti vW, ejsj vevRvi

XvKv-1100|

## **tKum@B AbyriY Kivi KihRi ciugk©**

### **ucQ uk¶iv\_¶**

Db¶¶ ukLb c×uZ ubf¶ Gg GW uk¶iv tçMötg fivZ¶l qvi Rb" `ž Ae GWžKkb Avcbv¶K Avšhi K Avfb`b Rvbr¶PQ| **Zžbvqj-K ukýv** (EDM 1106) tKum@eBiu Gg GW tçMötgi GKiu Avevk"K tKum¶ GB tKv¶m¶ D¶i"K" nj KtqKiu t¶ki ukýv i jý" I D¶i"K", KvVtgv, cKvmbK e`vi Ges , YMZgvb m@utK@avi Yv jv¶f Avcbv¶K mrvqZv Kiv| Avkv Kiv hvq, Avcub Ab" t¶ki ukýv e`vi &vetkl Y I ch¶j vPbvi gva"tg ubR t¶ki ukýv e`vi `enkó"vej I , Yu, Y m@utK@mivK avi Yv jv¶f KižZ mýg nteb Ges ukýv tý¶t bZb vPštariv I `vofwž veKv¶k Zžbvqj-K ukýv i Ae`vb Dcj wä KižZ cvi teb|

G tKum@eBiu i cv" melqe`tk Avgiv cv¶nu BDubtu fivM Kti¶u| cü\_g BDubtu Zžbvqj-K uk¶iv i `fç I `enkó" cñt½ Avtj vPbv Kiv ntq¶Q Ges Ab`vb" BDubU , tj vZ KtqKiu ube¶PZ t¶ki uk¶iv e`vi vetkl vetkl v K m@utK@Avtj vPbv Kiv ntq¶Q|

### **Zžbvqj-K ukýv (EDM 1106) tKum@B cvW I Ablaj tbi týt¶ Avcbvi KiYvq vK?**

- `ukLb c×uZi gj- K\_vB nj ubtR ubtR cto tkLv Ges ubtRi tPovq tkLv| Ab" K\_vq, G c×uZi gva"tg uk¶iv\_x© ubR `vqZ; ubtRi mpeavgtZv mgtg tkLvi Kv¶R ubtqv¶RZ nb| e`Z G D¶i"K"K mvgtb tižLB `ž Af GWžKkb Gi veirfbv¶Kv¶m¶ eB, tj v i¶PZ| GtZ fivMZ HK" i ¶iv Kti cv¶vi melqe`tk KZ, tj v BDubtu fivM Kiv ntq¶Q| Avevi BDubU , tj v¶K KZK, tj v cv¶v fivM Kiv ntq¶Q| cüZiu cvW cü\_ugK fite GKevi cožZ Avcbvi 40-45 vguBU mgq j vMte etj ati tbi qv ntq¶Q| cüZiu cv¶vi tktl Avcub ubtRB ubtRi cv¶vi AM¶hZ gj`vqb KižZ cvi teb| G Rb" cüZiu cv¶vi tktl i tq¶Q cv¶vEi cKgvj v Ges BDubtu i tktl i tq¶Q Pevšlgj`vqb cKgvj v|
- tKum@B covi mgq Kx Kx Kv¶Ri Dci , i azj w žZ nte?
  - cv¶vEi gj`vq¶bi cKgvj vi DEi ubtR ubtR Kiab| Avcbvi DEi , tj v mivK nj vK bv, Zv cv¶vi tktl t l qv ōmivK DEi ō t ¶L hvPvB Kti vbb|
  - cv¶vEi gj`vq¶bi me, tj v cŕkæ DEi mivK ntj Pevšlgj`vq¶bi cKgvj vi DEi i ubtR Kiab| tktlv³ cŕkæ DEi i mivK ntj cieZPBDubtu GuMtq hvb|
  - Avcbvi DEi , tj v mivK bv ntj cvW, tj v Avevi cob| cov tkl ntj cv¶vEi gj`vq¶bi cKgvj vi DEi Kiab| DEi mivK ntj ci cv¶v GuMtq hvb|
  - tKvb cv¶v me, tj v cŕkæ DEi mivK bv ntj tm cv¶vi ubw ō Ask Avevi cob| Gfite cüZiu BDubtu i cvW, tj v tkl Kiab|

eBiužZ th mg`l ubt`Rbvqj-K vPy e`vüZ ntq¶Q tm, tj v nj :



D×uZ



cv¶vEi gj`vq¶b I Pevšlgj`vq¶bi cKgvj v



cvW veivZ



mivK DEi

### **• cvW-mivqK Kg¶¶**

- ♦ `ž Ae GWžKkb GB eBiu Qvovl `vbxq vUDtUvi qvj tmv¶ti Avcbvi Rb" cüZ gv¶m (2q I 4\_@\_ev 1g I 3q i ¶evi) `vnu vUDtUvi qvj Kv¶mi e`vi MhY KtižQ| Gme Kv¶m thvM v žq Avcub eBiu cožZ vMtq tKvb mgm`vq cožj tm melžq cŕqvRbxq ciugk@I ubt`Rbv MhY KižZ cvtib| GQvovl Avcub mivmiv `ž Ae GWžKkb-Gi tKum@mgšqKvixi m½ thvMthvM Kti cŕqvRbxq ciugk@MhY KižZ cvtib |
- ♦ GQvovl `ž Ae GWžKkb ti v¶v I vUvžZ cüZ mBv¶n Avcbvi Rb" cvW melqv¶vEK Kv¶mi e`vi MhY KtižQ| Avcub vba¶i Z mgtg Nti e¶m Gme tmk¶b AskMhY Kti msikŕ týt¶ Avcbvi avi Yv mg× KižZ cvtib |

# mPcĪ

	cW	cŋv
<b>BDĪbU 1</b>	<b>Zĵbvġj K űkŲv</b>	01
	1 Zĵbvġj-K űkŲvi msÁv I cwi mi	02
	2 Zĵbvġj-K űkŲvi j Ų" I DŲĪ k"	06
	3 Zĵbvġj-K űkŲvi c×wZ	09
<b>BDĪbU 2</b>	<b>eŷj vŲ`Ųki űkŲv e`e`v</b>	15
	1 eŷj vŲ`Ųki i vóŲq ġj-bwZ Ges űkŲvi j Ų" I DŲĪ k"	16
	2 eŷj vŲ`Ųki űkŲv e`e`vi K vVŲġv	19
	3 űkŲv cĶvmb I e`e`vcbv	23
<b>BDĪbU 3</b>	<b>fviŲzi űkŲv e`e`v</b>	29
	1 RvZŲq űkŲvbwZ Ges űkŲvi j Ų" I DŲĪ k"	30
	2 űkŲvi K vVŲġvMZ iŲc	33
	3 űkŲv cĶvmb I e`e`vcbv	37
<b>BDĪbU 4</b>	<b>kĲj sKvi űkŲv e`e`v</b>	43
	1 kĲj sKvi eZŲvb űkŲv e`e`vi cUfŲġ Ges űkŲvi j Ų" I DŲĪ k"	44
	2 kĲj sKvi űkŲv K vVŲġv	47
	3 űkŲv cĶvmb I e`e`vcbv	50
<b>BDĪbU 5</b>	<b>Bsj`vŲŲi űkŲv e`e`v</b>	55
	1 cv_ŲġK I ġva`ŲġK űkŲvi ġġŲeKŲk	56
	2 űkŲvi eZŲvb K vVŲġv	60
	3 űkŲv cĶvmb I e`e`vcbv	65
	<b>MĚcÁŲ</b>	71

# Zj̄bvġj-K uk̄ŋlv

## fvgKv

cū\_exi me t̄tkB uk̄ŋlv cāvb j̄ŋ nj bvlmvi Kt̄i ˆˆwnK l gubvmK ŋgZvi weKvk  
 mvaṭb mnvqZv Kiv hv̄z mgvR l t̄tki meŋzxb mgv× ARṭb Zviv Ae`vb ivL̄z  
 cv̄i | j̄ŋŋi w̄K t̄tk t̄zgb tKvb cv\_Rˆ bv\_vKt̄j l uk̄ŋlv KivVt̄gv l e`vi w̄K  
 t̄tk t̄tk t̄tk h̄t\_ó cv\_Rˆ me`gvb it̄q̄Q | cŌZˆK t̄k w̄R w̄R D̄t̄kˆ l  
 cŌqvR̄t̄bi w̄bi t̄LB meṭPt̄q Dc̄thvMx uk̄ŋlv e`v cŌZṭbi l weKv̄tki Dci ˆiaZ;  
 Av̄ivc K̄t̄i | Hw̄ZnmvK t̄cŋlvCU, Av\_ŋvgv̄RK Ae`v l ˆw̄fiv̄MZ cv\_ŋKˆi KvīY  
 GK t̄tki uk̄ŋlv e`v Abˆ t̄tki c̄ŋ ūeū M̄h̄Y ev Ab̄ȳiY Kiv m̄e b̄q | Z̄te  
 Abˆ t̄tki uk̄ŋlv e`v Db̄q̄t̄bi w̄Q̄t̄b th w̄biš̄i cŌP̄ón, e`v\_Zv l m̄vdt̄jˆi Bw̄Znm  
 it̄q̄Q Zv h\_vh\_ PP̄ŋ gva`tg uk̄ŋK, uk̄ŋlv\_ŋ l uk̄ŋlv c̄kvmKMY w̄R w̄R t̄tki  
 uk̄ŋlv e`vi ˆenkóˆewj l ˆYv\_Y Av̄i l f̄vj f̄vte Dc̄j w̄ä K̄īz m̄ŋg n̄teb |

Av̄av̄bK uk̄ŋlv e`M̄t̄Yi ḡt̄aˆ G w̄el̄t̄q w̄ŋgZ t̄bB th uk̄ŋlv ḡv̄t̄bv̄q̄b l AM̄h̄Zi  
 w̄b̄ŏq̄Zv w̄eav̄t̄bi t̄ŋŋ̄t̄ Z̄j̄bv̄ġj K uk̄ŋlv w̄eṭk l Ae`vb it̄q̄Q | Z̄j̄bv̄ġj-K uk̄ŋlv  
 gva`tg Abˆ t̄tki uk̄ŋlv ˆenkóˆ, KivVt̄gv, c̄kvm̄bK e`v l ˆYMZgvb m̄áut̄Kˆ  
 mgˆK av̄iYv j̄vf Kiv m̄e | uk̄ŋlv m̄sˆv̄t̄i ev Db̄q̄t̄bi t̄ŋŋ̄t̄ Abˆ t̄tki uk̄ŋlv  
 e`vi w̄eṭk- lY, c̄ixŋY l ch̄ŋj̄vP̄bvi gva`tg w̄R t̄tki uk̄ŋlv e`v Av̄š̄R̄ŋZK  
 ḡv̄t̄bi t̄Kvb ch̄ŋq Av̄t̄Q Zv c̄w̄igv̄c Kiv hv̄q | Zv Q̄vov uk̄ŋlv t̄ŋŋ̄t̄ bZ̄b w̄P̄š̄lav̄iv l  
 ˆw̄fiv̄z m̄w̄b̄w̄kZ K̄t̄i w̄R t̄tki Av\_ŋvgv̄RK Db̄w̄Z m̄vab Kiv l m̄e n̄q |

GKw̄ ˆiaZc̄Yˆ uk̄ŋlv w̄elq Ges PP̄ŋ t̄ŋŋ̄t̄ w̄t̄m̄te Z̄j̄bv̄ġj-K uk̄ŋlv m̄áut̄Kˆ  
 c̄k̄ŋYv\_ŋK mgˆK Ávb l Dc̄j w̄ä ARṭb mnvqZv Kivi RbˆB GB BD̄w̄Uw̄U īw̄PZ  
 n̄t̄q̄Q | BD̄w̄t̄U w̄Z̄b̄U cv̄V it̄q̄Q | cŌg cv̄V Z̄j̄bv̄ġj-K uk̄ŋlv m̄sÁv l c̄w̄i mi Ges  
 w̄ŌZ̄xq cv̄V Z̄j̄bv̄ġj-K uk̄ŋlv j̄ŋ l D̄t̄kˆ m̄áut̄Kˆ Av̄t̄j̄vP̄bv Kiv n̄t̄q̄Q | ZZ̄xq  
 cv̄w̄Ūz Z̄j̄bv̄ġj-K uk̄ŋlv t̄ŋŋ̄t̄ thme c̄x̄w̄Z Aēj ˆb ev Ab̄ȳiY Kiv n̄q Zvi GKUv  
 w̄eṭk- lY w̄eiY cŌvb Kiv n̄t̄q̄Q |

cv̄V - 1 Z̄j̄bv̄ġj K uk̄ŋlv m̄sÁv l c̄w̄i mi  
 cv̄V - 2 Z̄j̄bv̄ġj-K uk̄ŋlv j̄ŋ l D̄t̄kˆ  
 cv̄V - 3 Z̄j̄bv̄ġj-K uk̄ŋlv c̄x̄w̄Z

### Zʒbvgj-K ɪkʻŋvi msÁv I cwi mi

#### Dʒik`

GB cW tkʻl Avcb —

- ◆ Zʒbvgj-K ɪkʻŋv mʻúʻKʻAvcbvi avi Yv e`3 KiʻZ cvi ʻteb;
- ◆ Zʒbvgj-K ɪkʻŋvi msÁv cŵvb KiʻZ cvi ʻteb Ges
- ◆ Zʒbvgj-K ɪkʻŋvi cwi mi mʻúʻKʻwefbæʻtʻki ʻtʻÁi gZvgZ chʻʻj vPbv I e`3 KiʻZ cvi ʻteb|

Ebwesk kZvāxi tkʻl bʻMv` Zʒbvgj-K ɪkʻŋv ej ʻtʻZ ɪkʻŋv e`e`v mʻúʻKʻZ mʻ I wewa-wearb cŵqʻtʻbi jʻtʻŋ` wewfbæʻtʻki ɪkʻŋv e`e`vi ZĒj I Zt`i Mšbv I wtkdY terSvZ| Zʒbvgj-K ɪkʻŋvi Ab`Zg RbK m`vi gvBʻtʻKj m`Wjvi meĒĠg Zʒbvgj-K ɪkʻŋvi msÁv I avi Yvi cŵvi NUVb| cieZʻZ K`vʻŪj, g`wvj bmb, nvbʻn& cŵjy ɪkʻŋvwe`MY Zʒbvgj-K ɪkʻŋv mʻúʻKʻwR wR avi Yv e`3 Kʻi b Ges Zʒbvgj-K ɪkʻŋvi msÁv cŵvʻtʻbi tPov Kʻi b|

### Zʒbvgj-K ɪkʻŋvi msÁv

m`Wjvi Zʒbvgj-K ɪkʻŋvi `ʻfc wtkdY KiʻZ thʻtq DʒjĠ Kʻi b: “In studying foreign systems of education we should not forget that the things outside the schools matter even more than the things inside the schools . . . . ‘A national system of education is a living thing, the outcome of forgotten struggles and difficulties and of battles long ago. It has in it some of the secret workings of national life.’ A\_ʻr th tKvb ɪkʻŋv e`e`vq we`ijq ewfʻZ wēlq I cwi ʻtek we`ij ʻtqi Af`šl`xY cwi w`wZ Aʻtʻŋv Kg , iæZcY`bq| RvZxq ɪkʻŋv e`e`v wbi šl` MvZkxj, `xNŋvjxb Avʻʻvj b I msMʻtʻgi ga` w`tq Mto I ʻv Ges RvZxq Rxeʻtʻbi Mfʻxʻi Gi exR wbnZ `vʻtʻK| ZvB wewfbæʻtʻki wewfbæDcv`vb i ayGKwĠZ Kiʻtʻj B tKvb t`ʻtʻki cYʻʻz ɪkʻŋv e`e`v Mto I ʻv, Gi Rb` cŵqvRb RvZxq Rxeʻtʻbi Mfʻxʻi AeMvnb| mʻz`ivs m`Wj vʻtʻi i `wʻfʻwʻtʻZ Zʒbvgj-K ɪkʻŋv nj Ggb GKwĠ Aa`qb ev cwi PPʻ wēlq hvi mivvʻth` Avgiv Avgvʻ`i RvZxq `emkó` I mĒyi Dci wfvĒ Kʻi wewfbæʻtʻki ɪkʻŋv e`e`v chʻʻj vPbv KiʻZ cwi Ges wbtʻRʻ`i ɪkʻŋv e`e`vʻtʻK m`wēRfvte Dcj wä KiʻZ cwi |

m`Wjvi hʻw` Zʒbvgj-K ɪkʻŋvi c\_ wbt`RK nb, Zte K`vʻŪj ntʻj b tmB cʻt`i cŵg cwi eʻRK| `fveZtB G cwi μgvi dtj Zʒbvgj-K ɪkʻŋvi tʻŋĠ Avi I we`Z. Ges e`vcK ntʻtʻQ| K`vʻŪj i fvlvq, The purpose of comparative education, as of comparative law, comparative literature or comparative anatomy, is to discover the differences in the forces and causes that produce differences in educational systems. mʻz`ivs, K`vʻŪj i gʻtʻZ th mKj KviY, kw`3 I Dcv`vb tKvb mgvʻtʻRi KwóʻtʻK iʻc`vb Kʻi Ges th mKj kw`3 cĒ`ŋ I cʻtʻivʻŋfvte mgvʻtʻRi ɪkʻŋv e`e`vʻtʻK wqšʻy Kʻi Zvʻ`i Aa`qbB Zʒbvgj-K ɪkʻŋvZĒj|

Aci GK wekIA g'vuj bmb Zǰbvǰj-K ukŋlv ej tZ K'vŰtj i avi YvB cŰq cYe<sup>es</sup>  
KtiŰb| Zui gŰZ ubqgvbM cirŋlv I ubixŋvi gva'tg mgvR, Kuó. I Zv' i ukŋlv  
Zǰbvǰj-K chŋj vPbvB Zǰbvǰj-K ukŋlvZÉ; hv wefbaeKuó i ukŋlv mv`k` I `emv`k`  
Ges Gme mv`k` I `emv`k` i KviY ubaŋY Ki tZ mŰpó nq|

### **Zǰbvǰj-K ukŋlv cwi mi**

Zǰbvǰj-K ukŋlv avi Yv GLb chŋi weKvkvb chŋq itq tMŰQ| dtj Gi e'vB ev  
cwi mi m'úŰKŰKvb meŋi<sup>z</sup> avi Yv t` I qv mnR bq| Zǰbvǰj-K ukŋlv msAv cŰvb  
cŰt½ Avgiv BtZvgta` m'vWj vi, K'vŰŰj I g'vuj bmb-Gi AwfgZ t\_ŰK G m'úŰK<sup>o</sup>  
ukŰlv avi Yv tctqŰQ| Gevi t`Lv hvK, Zǰbvǰj-K ukŋlv hŰt` i Ae`vŰb mgx nŰqŰQ  
Ggb Avi I KŰqKRb wekIA G m'úŰK<sup>o</sup> etj b:

### **AvB Gj K'vŰtj i AwfgZ**

K'vŰtj gŰZ Zǰbvǰj-K ukŋlv cwi mi iayukŋlv Kvvtgv, msMVb, cŰvmb,  
ukŋlvug I ukŋlv`vb c<sup>x</sup>uZi PPPev Aa`qŰbi gŰa`B mxgve<sup>x</sup> bq eis wefbaet`Űki  
শিক্ষা সংশ্লিষ্ট সমস্যাবলীর কারণ অনুসন্ধান এবং সামাজিক, রাজনৈতিক ও সাংস্কৃতিক  
Av`Űk<sup>p</sup> Avtj vŰK Hme mgm'v mgvavŰbi cŰpŰv m'úŰK<sup>o</sup>Aa`qŰb| Zǰbvǰj-K ukŋlv  
Avl Zvf<sup>z</sup> | G cŰt½ uZvb etj b: The comparative study of education must be  
founded on the analysis of the social and political ideals which the school  
reflects, for the school epitomizes these for transmission and for progress.

### **Aa`vck vŰŰKvj m nvbŰmi AwfgZ**

nvbŰmi gŰZ RvZxq ukŋlv e'e`v MŰo IŰV RvZxq PwiŰŰi Dci wŰE Kti, Avi RvZxq  
PwiŰ MŰo IŰV RvZxq I fvlvMZ msugkY, agŋ AvŰ`vj b Ges HwZnvvmK I  
tŰŰŰMvj K cwi cŰkŰZvi ga` w`Űq| mŰzivs, ukŋlv t`Űc Dcj wä Ki tZ ntj RvZxq  
PwiŰ MVŰbi GBme Dcv`vŰbi wekŰY I cŰqvRb|

RvZxq ukŋlv e'e`v thgb AZxZŰK A`Űkvi Ki tZ cvŰi bv, tZgvb fŰel`Űzi Dci I  
Gi QvqvZ ifx Ki tZ cvŰibv| nvbŰn j'ŋ` KtiŰb th wefbaet`Űki ms`vi, cŰv,  
HwZn`, cwi tek Ges BwZnvŰmi gŰa` ukŰyukŰymsMwZ iŰqŰQ Ges thŰnZzG, tji vi Dci  
wŰE KtiB ukŋlv e'e`v MŰo IŰvŰQ, tm KviŰY wefbaet`Űki ukŋlv mgm'vi tŰŰŰ I  
GKŰv A`mZ mv`k` j'ŋ` Kiv hvq| G KviŰYB uZvb Zǰbvǰj-K Avtj vPbv i wŰE tZ  
wefbaet`Űki ukŋlv mgm'vi mgvavb nI qv DvPZ etj gŰb Kti b|

### **tRGd m'vgvi Ges vRGm eŰDŰbi AwfgZ**

m'vgvi Ges eŰDŰbi gZvbvŰti Zǰbvǰj-K ukŋlv Avl Zvq ukŋlv tŰŰŰ t`Űk t`Űk  
cv`Ű` I AbMŰni Zvi KviY AvyŰvŰbi mvŰ\_ mvŰ\_ G mŰei chŋj vPbvI cŰqvRb|  
tKbbv th tKvb t`Űki ukŋlv e'e`v tmB t`Űki ivR%vZK, mgvmRK I agŋ cwi w`uZi  
Űviv ubqvšZ nq| thgb, tKvb t`Űki miKvi hŰ RbMYŰK MYZmšK AwaKvi t\_ŰK  
ewAZ Kti KŰvi kvmbvaxŰb Avex ivLŰZ Pvg Zte tmB t`Űki ukŋlv e'e`vi tgŰj  
PwiŰ nŰe j'ŋ` ciŰYi mnvqK| weŰUK Ges cŰk`vbx kvmbvgtj cŰxZ evsj vŰ`k  
fLŰŰi ukŋlv e'e`v Gi cŰó.D`vni Y|



### **udij c B tRvbn-Gi AvfgZ**

tRvbn Zjbvgj-K ukqvi cxiZtK ukqvgj-K cwi Kibv cVqtbi Rb` , iaZcY`etj gtb Ktib| Zjbvgj-K ukqvi Zvrch`ccht½ uZub etj b: “Comparative education, with its rapidly increasing resources and its hopes for better methods, seems admirably suited to provide a more rational basis for planning.”

### **GWgU tR uks-Gi AvfgZ**

uks-Gi gtZ Zjbvgj-K ukqvi nj Ggb GKU Aa`qtb ielq hv AvMZ fivel`tzi `tfc mautK`Avgt` i chfeqY I mxvstK mngex Kti| uZub gtb Ktib eZgub wekt; mvgvRK I ukqvgj-K mgnivej x tKvb GKU t`tki ctq GKv mgiavb Kiv mae bq, GRb` weifbat`k, mgiR I Kwoi cZ `wp w`tZ nte|

### **RR`eqvitWi AvfgZ**

Aa`vcK RR`eqvitW tKvb GKU ms`wZ. Mto DVri ucQtb th `vkBK I mvgvRK bniZ, tju Kvhrix `vtK ZviB ubvilt Zjbvgj-K ukqvtK GvMtg ubtq thtZ tPtqtQb| Zui gtZ, weifbawqvi e`e`vi gta` th miv`k`-`amv`k` `vtK Ges Zvt`i gta` th cvi `uvi K t`vl , Y eZgub, ZvtK mivKfite wektY KivB Zjbvgj-K ukqvi KvR| cKZctq, tgSj bniZ wfiEK HuznvmK wektY PPB nj Zjbvgj-K ukqvi|

### **kuBvvi-Gi AvfgZ**

kuBvvi Zjbvgj-K ukqvi cZciv` ielq Avil `uo Kti Dtg - L Kitz tPov KtitQb| uZub KZK, tju Acvinih`Dciv`vbi K\_v Dtg - L KtitQb hvi Dci ukqvi ZEjM I cttqvmK w`K eujvstK wbfP Kti| Zui gtZ, ukqvi `tfc I Kvvtg v wbfP Kti t`tki RvZxq Pwi I, tftMvj K cwi w`wZ, miv`wZK`-`AmvK`-`vkBK cUfug, ivR`wZK I A\_`wZK cwi w`wZ, ag,`Buznm I `et`ukK cftitei Dci|

Avgiv GB civV Zjbvgj-K ukqvi msAv cVtbi jtq` KtqKRb wektitAi `wfwz mautK`aviY jvf Kijvg Ges Zjbvgj-K ukqvi `tfc I `enko` mautK`Avil KtqKRb wektitAi gZvgZ Abgveb Kijvg| cieZP civV Avgiv Zjbvgj-K ukqvi jtq` I Dtik` mautK`AemZ nZ tPov Kie|



### **civVei gj`vqb- 1**

#### **A) eu ubePbx ckae**

mivK DEi wbt`Rgj-K AqiuutK eEivqZ Kiab| (D`vniY: Avcbri ubePZ DEiW K nTj GtK (K) eEivqZ Kiab)

1. Ab̄ t̄tki ḫḫv e'e-ḫ PPḫ gva'tg ḫbR t̄tki tKvḫU Dcj ḫä Kiv ḫvq?  
 K. ḫḫv\_ḫ Ae-ḫ  
 L. ḫḫv cḫvḫbi Ae-ḫ  
 M. ḫḫv e'e-ḫi ḫenkóveḫj  
 N. ḫḫt̄Ki ḫenkóveḫj
2. RvZxq ḫḫv e'e-ḫ ḫbi šli MvZkxj , ḫNḫvj ḫb Avḫ:ḫj b I msMḫtgi ga" ḫ"tq  
 Mto I t̄v – GvU Kvi K\_v?  
 K. mḫWj vi  
 L. nvbḫn  
 M. kvBvvi  
 N. tRvbḫn
3. tKvḫU GWgŪ tR ḫKs-Gi AvfḫZ?  
 ZḫbvḫjK ḫḫv –  
 K. cvḫ Kíbv cḫvḫbi Rb" , iazcḫḫ  
 L. ARvḫv fḫel t̄zi t̄fc tevSvi Rb" , iazcḫḫ  
 M. vevfbḫḫv e'e-ḫi vevḫt̄Yi Rb" , iazcḫḫ  
 N. vevḫ vevḫb cḫvḫbi Rb" , iazcḫḫ
4. ḫḫvi tḫt̄ t̄tk t̄tk cv\_R" I AbMḫiZvi KviY AvḫŪvḫbi Dci , iaz;  
 Avḫivc Kḫt̄Qb tK?  
 K. RRḫevḫi t̄W  
 L. ḫvgvi GŪ evḫDb  
 M. kvBvvi  
 N. vclḫj c B tRvbḫn

**Av) msḫḫB DĒi cḫæ**

1. GK t̄tki ḫḫv e'e-ḫ Ab̄ t̄tki cḫḫ MḫY Kiv mæḫ ḫK? ḫvḫmn Dḫt̄  
 Ki ab|
2. Zḫbvḫj-K ḫḫv mæúḫKḫmḫWj vḫi i avi Yv Kx?
3. Zḫbvḫj-K ḫḫv cḫt̄½ gḫvḫj bḫḫbi msAvḫU Dḫt̄ K i ab|
4. ḫbKj ḫm nvbḫmi gḫZ RvZxq Pvi T MVḫbi Dcv ḫb , t̄j v Kx?
5. Kḫt̄Ūt̄j i gḫZ Zḫbvḫj-K ḫḫvi Avl Zvfḫ vevḫ q , t̄j v Kx?



**mḫK DĒi**

- A) 1| M, 2| K, 3| L, 4| L|

**cW 2**

**Zḫbvḫj-K ḫḫvi j ḫḫ I Dḫik"**

**Dḫik"**

GB cW t̄kḫI Avcḫb —

- ◆ Zǰbvgj-K ukʻvi gj- j ʻŋ Dǰ ŪL KiǰZ cviǰeb Ges
- ◆ Zǰbvgj-K ukʻvi weǰkl Dǰi k`vevj eYǰv I e`vL`v KiǰZ cviǰeb|

wevfbet`tki ukʻvi Zǰbvgj-K Aa`qǰbi gva`tg ukʻvi gvǰbvbqǰ I AvaybKxKiǰYi j ǰŋ ukʻvi ms`vǰi cwi Kǰi bv MǰhY Kiv mǰe| ukʻvi I mgvR mǰúǰK`cǰqvRbxq Z`mieivn Kǰi Dbǰb I ms`vǰi Muzavivi w K wǰt`Rbv t`qvi tǰŋǰ Zǰbvgj-K ukʻvi Ae`vb Ab`Kvhǰ Zǰbvgj-K ukʻvi gj- j ʻŋ nj wevfbet`tki ukʻvi e`e`vi AvfÁZvi AvǰvǰK wR t`tki ukʻvi e`e`vǰK Mfxi fivǰe Dcǰwǰ Kiv, ukʻvi I Áw I fuj w K wǰbǰY Kiv Ges cǰqvRbxq ms`vi I Dbǰǰbi j ǰŋ` , iǰZcY`Z` msMǰh I h\_vh\_ cǰqvM Kiv| GB gj- j ʻŋ` tǰwǰvǰvi Rb` Zǰbvgj-K ukʻvi gva`tg KǰqKw weǰkl Dǰi k` ARǰ Kiv cǰqvRb|

**evj`Eǰj-K Dǰi k`**

Zǰbvgj-K ukʻvi GKw cwi ŪZ`cY`ÁvbPPP tǰŋǰ | Ab` t`tki ukʻvi e`e`v mǰúǰK` evj`xǰ Abǰvǰv I chǰj vPbv e`wǰi wR Ávb I DcǰwǰǰK cwi cY` Dbǰ Kǰi Ges Zvi Ašf ǰ Ggbfivǰ weKwKZ Kǰi th tm Ab`vb` t`tki RbMǰYi tǰŋǰǰZ wǰRǰK mg`K Dcǰwǰ Kivi mǰhvM cǰq| Gi dǰj ukʻvi weÁvb I mvgwRK weÁvǰbi tǰŋǰǰ bZǰ Ávǰbi weKv I cǰqvǰMi ǰvi DǰbǰvǰZ nq|

**cwi Kǰi bvgj-K Dǰi k`**

cw\_ exi me t`kǰ AvR mgw`x i j ǰŋ` Dbǰb cwi Kǰi bv cǰvqǰ Kǰi Pj ǰǰ| ukʻvi tǰŋǰǰ I cǰZw t`k bZǰ bZǰ bwiZ I KgǰwP wǰtǰ GwMǰq Pj ǰǰ| Gme bwiZ I KgǰwP cǰvqǰ I ev`éqvǰb tKivǰfc`ǰǰZv ev`kw\_j` cǰkǰbi mǰgvb` AeKvkl tǰb, Kvi Y Gi mǰv\_ j ǰŋ j ǰŋ bvwǰi tKi fuj g` I fvel`Z RwoZ| AZGe, Gme wǰtǰ wmxvšf ÁwUgʻ I cwi c` nǰZ nǰe| Gǰŋǰǰ Zǰbvgj-K ukʻvi mǰysMwZ I mgǰZwǰZ Z` cǰvǰb mǰvqK nǰZ cǰi| G cǰh`ǰ tRvǰǰn etj b: “Comparative education, with its rapidly increasing resources and its hopes for better methods, seems admirably suited to provide a more rational basis for planning.”

**DcǰhwMzǰj-K Dǰi k`**

ukʻvi A\_ǰwZK gj` AvR cǰZwǰZ mZ`| Pxb, Rvcv I tKwǰvǰ gZ wKQwKQy t`k Kg`AvfÁZv ARǰǰK ukʻvi GKw AZ`vek`Kxq A½ etj gǰb Kǰi Ges G bwiZi cǰZdj b Nuǰtǰ Gme t`tki A\_ǰwZK AMwZi mwaZ nǰtǰǰ| cǰvǰšfǰi fviZ I evsj v`tki gZ AǰbK t`kǰ ukʻvi t`tki A\_ǰwZK mgw`x i Dcvq wǰtǰte` , iǰZj bv w`tǰ ukʻvi cǰvi, weǰkl Kǰi D`P ukʻvi cǰvi Ggbfivǰ Nuǰtǰǰ th teKvi mgm`v Av I cǰKU nǰq Dǰvǰǰ| Gi mǰv\_ Avevi hǰ nǰtǰǰ teb tWb (brain drain) mgm`v| AZ`šf cwi Zǰvǰci wǰlq th Abǰvǰ I DbǰbKxj t`k\_ tǰv cǰǰ A\_`e`q Kǰi th tgav weKv Kǰiǰ Zv tkl chšf Dbǰ t`k` vǰvšfǰi Z nǰ`Q, A\_`w` w``t`k\_ tǰvi e`tǰi mgǰj tǰvM Kǰiǰ Dbǰ t`k\_ tǰv| Gme mgm`vi mgvavb tǰZ nǰj Zǰbvgj-K ukʻvi AvǰvǰK ukʻvi cǰqvMkxj Zv I DcǰhwMzǰvi wǰlq w fivǰZ nǰe|





### ciVViEi gj`iqb- 2

#### A) eU űbePbx cĕæ

műWK DĒi űbĕ`Rgj-K AŷiűűK eĒűiqZ Kiab | (D`vniY: Aűcbvi űbeűPZ DĒiű K ntj GĕK Ⓚ eĒűiqZ Kiab)

1. Zĕbűgj-K űkŷvi j ŷĕ tKűbű?
  - űewfbaĕ`ĕki tĕŷĕZ űbR t`ĕki
  - K. űkŷvi e`e`ĕK Mfxi fiĕe Dcj űä Kiv
  - L. űkŷvi űau I fiy ű`K űbaŷY Kiv
  - M. űkŷvi ms`vi I Dbqĕbi j ŷĕ Z` msMĕ Kiv
  - N. Dĕĕi me, űj
2. eűeűĒgj-K Dĕĕk` ej ŷZ Kű tevSűq?
  - K. űkŷvi ŷĕĕĕ D`űeYűgj-K KgűűP cĕZĕ
  - L. bZĕ Aűĕbi űeKűk I cĕűűMi űvi DĕbűPb
  - M. mgűx i j ŷĕ Dĕqĕ cűi Kĕ bű cĕűqĕ
  - N. űkŷvi ms`vi műĕbi j ŷĕ Z` msMĕKiY
3. tKűbű D`űebűgj-K KgűűP bq?
  - K. gűűDj vi c`űZ
  - L. `űkŷY c`űZ
  - M. e<sup>3</sup>Zű c`űZ
  - N. bZĕ cĕűű

#### Aű) msűŷB DĒi cĕæ

1. Zĕbűgj-K űkŷvi cűi Kĕ bűgj-K Dĕĕk` ej ŷZ Kű tevSűq?
2. Zĕbűgj-K űkŷvi DĕĕűMZűgj-K Dĕĕk` ej ŷZ Kű tevSűq?
3. Zĕbűgj-K űkŷvi eűeűĒgj-K Dĕĕk` ej ŷZ Kű tevSűq?
4. Zĕbűgj-K űkŷvi gj- j ŷĕ Kű?



#### műWK DĒi

A) 1 | N, 2 | L, 3 | M |



• **HuZnumK cxiZ**

mÿi AZxZ t\_tK Avic Kti bvbv cZeÜKZv I bvbv chiq AwZug Kti ukŕv AvaybK tti Gtm tctiQfQ| ukŕv tPZvri mugieKviki GB chiq,tjvi Zjbvgj-K wefk- IYB HuZnumK cxiZ| Zjbvgj-K ukŕvi tŕŕt GB cxiZi Dŕj- LthvM Ae`vb Ab`xKvhŕ GB cxiZi ØvivB Avgiv RvbŕZ tctiQ tKvb t`tki ukŕv iPšri weeZŕbi tŕŕt tKvb tKvb Dciv`vb,tjv wefkl fite KvhRix\_vfK| iayZvB bq, AZxZ AwfÁZv Avgv`i fiel`tZi ct\_i ubt`R t`q| tm Kvity GB cxiZ thgb GKw`tK AZxZ BwZnum Ges Zvi wefbaDciv`vb,tjvŕK RvbŕZ mrvh` Kti, tZgub Ab`v`tK fiel`tZ Avgv`i KiYxq m`útkŕbt`Rbvl t`q| Avevi wefbaDciv`vb,tjv wefk- IY Kitz wMŕq Avgiv wefbaevgvrRK I ivR%wZK mslMvb,tjvi m½l cwiwPZ nB| GB mslMvb,tjv ukŕvŕK euj vs`tk cŕimeZ I ubqwišZ Kti |

ubtKvj vm nvbŕn GB cxiZi Dci mwekl ,iaZj Avtivc KtitQb| Zvi gŕZ Guw Zjbvgj-K ukŕvi meŕaK Rbvcŕ cxiZ| cKZctŕ GB cxiZ chŕ nevi m½ m½B Zjbvgj-K ukŕv GKw ubR`^cwi gUj Mto ZŕtZ mŕg nq|

K`vEj I GB cxiZi ,iaZj A`xKvi Ktib vb| Zvi gŕZ HuZnumK cxiZ iaywefbae t`tki ukŕv mgm`vi Drm RvbŕZB mrvh` Ktiub, eis ukŕv ubqšK wefbae Dciv`vb,tjvŕKl Ave`vi Kti w`tqfQ|

tdWwi L kuBwvi gŕb Ktib GB cxiZi Øviv th Dciv`vb,tjv RvZxq Pwi` I RvZxq ukŕvŕK cŕimeZ Kti tmB Dciv`vb,tjvi GK e`ubŕ wefk- IY Kiv m`e nq|

HuZnumK cxiZi Ae`vb hw` I A`xKvi Kiv hvq bv, Z\_vvc GK\_v wK th, AvaybK cwl\_exi hveZxq mgm`v AZxZ AwfÁZvi cwi`ctŕŕtZ wefk- IY Kiv m`e bq| wefkl Kti, AvaybK chŕŕ weÁvb GZ `zZ MwZtZ AMŕhigvb th Zvi m½ mgvb c`ŕŕtZ AMŕhi nŕZ Avgv`i wePvi eyx`l evievi chŕ`lnq| tmBtŕŕt AZxZ AwfÁZv GK epr I e`vcK cŕ`ebvi cŕ`igK cŕ`wzi `wqZjcvj b Kitz cvti gv` |

• **mgvR weÁvb wfiEK cxiZ**

GB cxiZ Abymti, tKej gv` mvgvrRK Dciv`vb,tjvi wfiEKZB Zjbvgj-K ukŕvi PPŕ Kiv nq| gvBtKj m`wvjvi ntjb GB cxiZi Ab`Zg cŕ`v| 1902 Lióvã wZub wj`LwQŕj b, Bsj`vŕŕi ukŕv e`e`vi chŕjvPbv wev`Obŕvte Kiv m`e bq| GB chŕjvPbvi Rb` thgb cŕqvRb Bsj`vŕŕi mvgvrRK cwi gUjti wefkl Y, tZgub cŕqvRb Rvgŕb, Avŕgwi Kv, dvY Ges Ab`vb` t`tki ukŕv e`e`vi m½ mvgvrRK cUfiqKvi wefkl YI |

wU n`wmi mb mgvR weÁvwfiEK cxiZi j ŕŕ Avtj vPbv Ktib| wZub etj b ukŕvi j ŕŕ`B Dchŕ Ges Av`k`bvMwi K`Zwi Kiv| Avevi GB bvMwi K`Zwi Kitz nŕe GKw t`tki mvgvrRK Dŕik` cŕŕYi mrvqK wntmte| GB Kvity mvgvrRK Ae`vi tctŕvctUB ukŕv e`e`v Avtj wPZ nI qv DwPZ|

metPtq eo K\_v nj, GB cxiZ ikflitit čhy nevi mt½ mt½ AvšRuzK mvs-wzk  
fve weibgtqi, iaž; Ges c0qvrbiqZv AvR meRtbi -fKuZ tctqtQ|

uKš' GB cxiZtZ mgvR mEyi Dci AZwaK, iaž; AvtimcZ nevi dtj e-ir3mEý  
DtcvflZ ntqtQ| ZvQvon tKejgvĪ mvgvRK e'e-vB GKuW t'tki ikflv e'e-vi  
GKgvĪ wqšK ntZ cvtibv|

**• wetk0 YvZK cxiZ**

GB cxiZ Abynti, me0g tKvb GKuW t'tki ikflv e'e-v m-utK9ewfbaez\_ msm0h  
Kiv nq| Zvici msMpxZ Z\_ ,tjvK Zžbvgrj-K fite wetePbv Kiv nq| Gici  
Z\_ ,tjvK KZK, tjv tkYtZ web-t'Kiv nq Ges GB webvm mvaŧbi cvitc0flZ th  
dj k0Z j ä nte ZvtKB umxvšĪntmte M0Y Kiv nte|

AZ'vaybK Kvtj Zžbvgrj-K ikflvi tflit GB cxiZ wetkl fite čfve we-li KitZ  
mflg ntqtQ| eZ0vb čEYzvb nj, th tKvb weAvtbi gZ Kti Zžbvgrj-K ikflitKl th  
tKvb Z\_ hvpvb Kti t'ltZ nte| ikflv wqšY Kti Ggb Dcv'vb,tjvK tKej  
ch0j vPbv KivB eo K\_v bq hZUv m-ē wlvzfite Zvt' i wetk- IYI KitZ nte|  
Rvcvb I Avtgui Kvq GB cxiZ wetkl fite čPwj Z|

**• msŧk- IY cxiZ**

wetk0 YvZK cxiZi wK weciZ ifcB nj msŧk0 Y cxiZ| GwG0 tr uKs ntj b Gi  
č0vb čE3v| 1962 Li0vŧā wZvb Zui World perspective in Education bvtgi  
eBiuŧZ GB cxiZ wbtq Avtj vPbv Ktiŧqb| wZvb etj ŧqb, 00nkflvi w'K t\_ŧK mgM0  
cĪ extK GKiu GKk wntmte M0Y KitZ nte| tKvb GKuW t'tki ikflv e'e-v tmB  
wef' ikflv e'e-vi wbiŧL wePri Kti t'ltZ nte| 00 GB cxiZi c0qvm i agvĪ Avi-  
ntqtQ| GLbi hŧ\_ó cixflv wbxflv tkl nqvb| Zvb GB cxiZ wbtq GLbi tKvb K\_v  
ej evi mgq Avtmvb|

tgvu K\_v wvttjv GB th, Zžbvgrj-K ikflvq e0wea cxiZ wqzB e'eüZ ntQ|  
cKZcŧfl tKvb cxiZiB m-uy-cixflv wbxflvi li GLbi AwZmvsĪnqvb| Zvb tKvb  
cxiZi c0qvmK mdj Zv I DrKI-m-utK-tkl K\_v ejv m-ē bq| tKbbv,  
cwieZ0kxj Zvb ikflvi ag0 GB cwieZ0kxj Zv AvtQ etj B hM t\_ŧK hMvšŧi, Kvj  
t\_ŧK Kvjvšŧi gvbe mfZvtK etfl aviY Kti ivltZ cvitQ ikflv| GB  
cwieZ0kxj Zv AvtQ etj B ikflv gvbe Pwi ŧK I gvbe mgvRŧK hŧMvcthvMx Kti,  
KvtjvcthvMx Kti Mto ZžtZ cvitQ| Zvb tKvb ikflvi Pwi ŧ wbaŧY GK AwZ `jfh  
KvR Ges tmB KvR meRvtj i Rb" GKiu mybw 0 cxiZ Avie0vi I m-ē bq|





### ciVvEi gj`iqb - 3

#### A) eU ubePbx cKæ

mWVK DEi ubt` Rgj-K Aqi uWtK eFvqZ Kiab | (D`vniY: Avcbvi ubePZ DEi uW K ntj GtK K) eFvqZ Kiab)

1. weifbat`tki ukqv e`e`vi m`k` I `emv`tk`i Dci ,iaZ;Avtivc Kti tKvb cXvZ?  
 K. HwZnvmK cXvZ  
 L. eYDvgj-K cXvZ  
 M. wek- IYvZK cXvZ  
 N. DrKIAcKIcXvZ
2. tKvb uW wek d YvZK cXvZi `enkó`?  
 K. ukqv e`e`v m`u`K`Z` msMh, tkYweb`vm I umxvS`MhY  
 L. mgvRK e`e`vi tcdqvc tU ukqv e`e`vi chqj vPbv KiY  
 M. ukqv e`e`v m`u`K`mavi Y eYDv cDvb  
 N. ukqv e`e`vi mgveKvtki HwZnvmK wek d Y
3. ubtKvj vm nvtmi gtZ Zjvvgj-K ukqvi mehaK Rbvc d cXvZ tKvb uW?  
 K. wek d YvZK cXvZ  
 L. mgvR weAvb wfvEK cXvZ  
 M. HwZnvmK cXvZ  
 N. mstkd Y cXvZ
4. mgvR weAvb wfvEK cXvZi cE`3v tK?  
 K. m`Wj vi  
 L. K`vtUj  
 M. weqv tW  
 N. nvtm

#### Av) msuqB DEi cKæ

1. Zjvvgj-K ukqvi AvvZ cXvZ ,tj vi bvtgtj L Kiab |
2. Zjvvgj-K ukqvi DrKIAcKIcXvZtK ucvi msL`vb d cXvZ ej v nq tKb?
3. ubtKvj vm nvtmi gtZ Zjvvgj-K ukqvi mehaK Rbvc d cXvZ tKvb uW? e`vL`v`b |
4. n`vii m`bi gtZ omgvR weAvb cXvZi d ,iaZ; Kx?



#### mWVK DEi

A) 1| N, 2| K, 3| M, 4| K |



### Povšgjiqb

#### A) eü ubePbx cġæ

mWK DĒi ubt` Rgj-K AŋiUŋK eĒiqZ Kiab | (D`vniY t Avcbvi ubePZ DĒiU K ntj GtK (K) eĒiqZ Kiab)

- Zžbvj-K ŋŋv ej tZ K`vtŪj Kx eyStqtOb?
  - K. th mKj kw<sup>3</sup> cġ`ŋ I ctivŋfvte ŋŋv e`e`vtK ubqšY Kti Zvt`i Aa`qb
  - L. RvZxq `enkó` I mĒyi Dci vfiĒ Kti weifbæt`tki ŋŋv e`e`vi chġj vPbv
  - M. weifbækuó mrv`k, `emv`k I Gt`i KviY ubaŋY
  - N. ubqgvbŋ cixŋv ubixŋvi gva`tg mgvR, Kuó. I Gt`i Zžbvj-K chġj vPbv
- weifbæt`tki ŋŋv mgm`vi tŋtġ GKUW A`mZ ŋcj t`Lv hvq| ubtKvj vm nvtġmi gġZ Gi KviY tKvbU?
  - K. mKj t`tki ŋŋvi BwZnm cġq GKB iKg etj
  - L. mKj t`tki RvZxq `enkó` cġq GKB iKg Dcv`vb w`tq MwZ etj
  - M. mKj t`tki ms`vi, cġv, HvZn, cvġtek I BwZnġmi gġa` msMwZ itqtQ etj
  - N. mKj t`kB weifbæRwZi msugkġY Mto I tV etj
- ŋŋvi DcthwMZvgj-K Dġt`k`i tŋtġ tKvbU Dci , iæZ; t` I qv nq?
  - K. ŋŋvi cġqvMkxj Zvi Dci
  - L. ŋŋvi cġvti i Dci
  - M. ŋŋvi eyx`xB AbŋvUvb I chġj vPbv Dci
  - N. ŋŋvi MwZavv ubaŋt`Yi Dci
- teb tWb (brain drain) mgm`vi KviY ŋK?
  - K. A`ŋwZK mgw`xi Afve
  - L. tgav weKvtki mġhvġMi Afve
  - M. ŋŋv tŋtġ Kg`AvfÁZvi Afve
  - N. ŋŋvi cġqvMkxj Zv I DcthwMZvi Afve
- tKvb t`tki ŋŋvi e`e`vtK wek; ŋŋvi e`e`vi ubwiġL gj`iqb Kivi Dci tRvi t` I qv nq tKvb c`wZtZ?
  - K. HvZnmK c`wZtZ
  - L. msġkŪIY c`wZtZ
  - M. mgvR weÁvb vfiĒEK c`wZtZ
  - N. weġkŪ YvZK c`wZtZ

6. tKvb c×wZwŷK Zŷbvgj-K wkŷvi cwi msL`vb c×wZ bŷtŷl AwfinZ Kiv nq?  
K. mgvR weÁvb wfiwĚK c×wZ  
L. mstkdŷ c×wZ  
M. eYŷvgj-K c×wZ  
N. DrKIŲAcKIŲc×wZ

**A) iPbvgj-K cŷæ**

1. Zŷbvgj-K wkŷvi ej tZ Kx tevSvq?
2. Zŷbvgj-K wkŷvi PPP ev Aa`qtbi wefqvej m`útkŲŲRb weklŷÁi AwfgZ wj wec× Kiab|
3. Zŷbvgj-K wkŷvi wekl Dŷŷk`vej eYŷv Kiab|
4. Zŷbvgj-K wkŷvi wefbc×wZi , iæZcŷŲewkó" Dŷŷŷ Kiab|
5. Zŷbvgj-K wkŷvi tŷŷŷ DrKIŲAcKIŲc×wZi , iæZŷDŷŷŷ Kiab|
6. Zŷbvgj-K wkŷvi tŷŷŷ HwZnwmmK c×wZi , iæZŷDŷŷŷ Kiab|
7. mstkdŷŷI weklŷ c×wZi cv`Ų" wbjcŷ Kiab|



**mŷK DĚi**

A) 1| K, 2| M, 3| K, 4| N, 5| L, 6| N|

# evsj vř`tki ukŕŕv e`e`v

## figKv

cŕlexi cŕZiU ř`tki ukŕŕv e`e`vB Zvi ubR`^RvZxq Av`k©I ms`uZi ewntcKvk|  
 ukŕŕv e`e`vB RvZxq ms`uZ. I Huzřn`i aviK I evnK| Avevi RmZi fiel`r Avkv-  
 Avkv•ŕŕvi cŕZdij Z nq ukŕŕv e`e`vi gvařg| cŕlexi mKj ř`tki gZ evsj vř`tki  
 tejvqI G K\_v, řjv cŕhvR`| řaxbZvi Ae`einZ cřiB 1972 mřb iŕPZ msıeavřb  
 mŕyúofıře `elg`nxb, MYgŕx I meRbxb ukŕŕv e`e`vi K\_v Dřj - L Kiv nřqřQ| ejv  
 nřqřQ ukŕŕv nře MYgŕx Ges RıebıřıEK hv Rıetři Pıın`v tgUřřZ mŕŕg nře|  
 cŕugK ukŕŕv nře cŕZiU ŕki i Rb eva`Zvřj-K I A%eZıubK| GKıř`řK ukŕŕvi , YMZ  
 gvřbıvqřb, Acııř`řK ř`tki cŕZiU gvřřı i Rb` ukŕŕvi ubđqZv ıeavb Kiv ivřřı  
 Ab`Zg `ııqZ; eřj Dřj - L Kiv nřqřQ| řaxbZvi ci ukŕŕv ms`vi I , YMZ gvř  
 Dbqřři j řř` meŕŕg 1974 mřb KřivZ-G-Lŕv ukŕŕv Kıgkb ııřcvU`cKıvkZ nq|  
 Gici 1979 mřb GKıU AřeZřKıj xb ukŕŕvıbmZ I 1988 mřřj gıdR Dııı b Kıgkb  
 ııřcvU`cKıvkZ nq| ŕKř`AvR chřıımi Kvi KZř `xN`řgqı`x mıvııMıK iřřıLv I ıı K  
 ııř`Rbı m`ıřj Z řKvb cřř% bııZ cŕřb Kiv m`e nqıı| G řcŕřřřZB eZřıv BDııbřU  
 evsj vř`tki ukŕŕv e`e`vi KřqKıU ıı K ııřq Avřj vPbv Kiv nřqřQ| BDııbııU ııZbııU  
 cvřV ıef<sup>3</sup> | cŕg cvřV evsj vř`tki ivřřq gj-bııZ I Gi Avřj vř`tki ukŕŕvi  
 j řř` I Dřř`k` m`úřK`Avřj vPbv Kiv nřqřQ| ııZxq cvřV evsj vř`tki eZřıv ukŕŕv  
 Kıvřřgv Ges ZZxq cvřV evsj vř`tki ukŕŕv cřıvb I e`e`vıcbı m`úřK`Avřj vPbv Kiv  
 nřqřQ|

- cvV - 1 evsj vř`tki ivřřq gj bııZ Ges ukŕŕvi j řř` I Dřř`k`
- cvV - 2 evsj vř`tki ukŕŕv e`e`vi Kıvřřgv
- cvV - 3 ukŕŕv cřıvb I e`e`vıcbı

**ejsj it`ki ivóŋq gj-bmwZ Ges ukŋvi j ŋ` I Dfík`**

**Dfík`**

GB cW tkfI AvciB —

- ◆ ejsj it`ki ivóŋq gj-bmwZ Dfj L KitZ cvi teb;
- ◆ meRbxb ukŋv cŋt½ ivóŋq gj-bmwZ e`vL`v KitZ cvi teb Ges
- ◆ ivóŋq gj-bmwZi Avfj vtK ukŋvi j ŋ` I Dfík` eYŋv KitZ cvi teb|

**ivóŋq gj-bmwZ**

msieavtb eivŷ gj-bmwZ, tjv ntjv RvZiqZvev`, mivmRK I A\_ŋbwZK b`vquePvi (mgvRZš), MYZš; I gvbermaKvi Ges agfŋ `faxbZv| ejsj it`ki msieavtb GB gj-bmwZ, tjv t\_ŋK D`M`Z AvI ukQygvj-bmwZi Dfj L itqtQ| G, tjv nj- t`tki AbMŋi gvbyfK tkvI Y t\_ŋK gvŷ, bMi I MŋqvÁtj i gta` `elg` `hKiY, Rb`f` I `bwZKZvi DbwZ, mŋhvMfI mgZv, KtgŲ AvA Kvi, RvZiq mveŋŋŋZj I mgZvi cŋZ k`v Ges AvšRŋZK kwšf, vbi v`cEv I msnwiZi Dbq| G OvovI MYg`x I meRbxb ukŋv cŋt½ msieavtbi vŌZiq fvtMi 17 b`f AbjPQf` ej v ntqtQ:

**ivó<sup>a</sup>**

- K. GKB c`wZi MYg`x I meRbxb ukŋv e`e`v cŋZôvi Rb` AvBtbi Ōviv vbaŋi Z `li chšf mKj evj K I evnj Kvtk A`vZwbK I eva`Zvgj-K ukŋv vtbi Rb`;
  - L. mgvRi cŋqvRtbi minZ ukŋvtK m½wZc`Kvi evi Rb` Ges tmB cŋqvRb vvx Kvi evi Dfík` h\_vh\_ cŋkŋYcŌB I miv "OvcŌYvii Z bvMvi K mŋó i Rb`;
  - M. AvBtbi Ōviv vbaŋi Z mgtqi gta` vbi ŋi Zv `i Kvi evi Rb`;
- KvhRi e`e`v MŋY Kvi teb|

**ukŋvi j ŋ` I Dfík`**

ejsj it`ki ukŋv e`e`vi gv- j ŋ` I Dfík`vej gj-Z 1974 mvtj i KzivZ-G-Ljv ukŋv Kvgkb vvtcvfUŲ Avfj vtK w`i Kiv nq| vvtcvfUŲ Dfj L Kiv ntqtQ, Ōŋkŋv e`e`v GKvU RvwZi Avkv-Avkv`ŋv ifcvqvtbi I fveI`Z mgvR vbgŋYi nviZqvi|Ō KvŋRB ukŋvi cŋvb j ŋ` ntPQ mivÁZ Ávb, AvfÁZv Ges HvZn`ŋK bej ä Ávb I AvfÁZvi Avfj vtK mÁveZ Kf i `^`^RvZiq Av`kŌ gv`tevtai vfiÉfZ bZb mgvR mŋó i tŌYv mÁvi Kiv Ges RvwZi AmŌvZi c\_ŋK mŋg Kiv| AvI GB Kvii`ŋZ gv- j ŋ` tŌŌvfvri Rb` ejsj it`ki ukŋvi Dfík`vej vbyŷZ ntqtQ vbgiefc:

- K. f`kčŲ I mbyMvi KZ; Gi A\_ŋntPQ cŋZ`K bvMvi K Zvi f`kŋK fij evmte| GB Dfík` cŋZv bvMvi K RvZiq msnwiZtevtā DŌy nte, mKtj i Avkv-Avkv`ŋvi mvt\_ GKvZfZv cŋvK Ki te|

- L. **agr օ mnbkxj Zvt** ivtճi agr օ bnx Z RvxZ-ag՝nbnեթk՝l mKj bMnիtKi mg AաKvi I mթիVM մյբav nbnՕZ KtiժQ| GB bnxZi մթ½ մ½նZcԿ՝l մյրցուՏZ gube Rxeթbi Rb՝ cՕquRbxq gj֊թeva I և Yvej x յեKվtկi e՝e֊v KivB նե յԿղի մեթPթq eo KivR|
- M. **kթgi ghթvt** KվRi cՕZ Abıvı I kթgi ghթv ՚vթb KՋvթeva tՊkի MVBgj-K Dbթb KգRկvՕtK e՝vnZ KtiժQ| GB Ae֊v t֊tK gյթ՝ tctZ ntj յԿղիv e՝e֊vq nvtZi KվRi Dci յեթl և յաջ; AvՊıvc KtiZ նե| th th KվRi Dchթ՝ ZvtK tmtթթt մթթb cՕkԹ AZ՝եկ՝K|
- N. **Kk j x Rbm֊u՝ մյթ Kk j x Rbm֊u՝ մյթi** Rb՝ thgb GKıv՝tK mgMՕնԿղիv e՝e֊vq cՕquMgղ֊Zvi gva֊tg gıvımk kթgi մթ½ Drcv՝bgղ֊x KvıqK kթgi mgՏթ մvab KtiZ նե, tZgıb Ab՝ıv՝tK Kւլ.յեAvb, Kj v, ւկի, cthթթ, ıPııKrmv, emıYR՝, ւԿղK ւԿղY cթւZ. eւղղ֊x ւԿղıavıv cՕZԹ KtiZ նե|
- O. **gubeZv I յեկըմիKZt** tkıvYnx mյi mgıvR մյթi gnr tctYıq յեթkի mKj mslMոցx RbZvi cՕZ eՕZ; I ևvZtZji n֊l cthıvı Z Kivi Av՝k՝, ւԿղիv t֊tK jvf Kite|
- P. **bnZK gj֊թevat** յagıv՝ K֊vi eyj ıvՊq Av՝kթK e՝vL֊v bv Kti cՕZıւ յԿղիv\_թ յթb thb e֊եZvi ՚ւկթ֊q v hvq tımb jթթ՝ ւԿղիv bnZKZvթeva մյթtZ mnıvqK նե| Ab՝vթji յեıթx mr mıvm thvMթե ւԿղի| KviY ւկi ւԿtկi I Zıթթi յթb gj֊թeva մյթ I Pıvı MVթb ւԿղիv յեKի tıb|
- Q. **mgıvRK cııeZթbi nıvZqvi** ՚tթct th tKvb cııeZթb ւԿղիv Zvi cթvb nıvZqvi | cՕZıւ e՝ıթ՝ Zvi cՕZfv I cթYZv Abıvqıx mgıvR Rxeթb I e՝ıթ՝MZ Rxeթbi mKj tթթt մRbկj ՊgZv ıbթq AMթi ntZ cvթı | Gթթթ ւԿղıvթKB evnb ınmıթe e՝envı Kti GB mgıvRi mKj cթKı Kms֊vı, AbıPıvı I յbnZı Aemvb Nıւթq bZb mgıvR Dcnvı ıvՊZ նե fıel՝r cՕRbթK|
- R. **cՕquMgղ֊x A֊ջbnZK AMթıvızi Abթթj ւԿղի** RvxZ ınmıթe Avgıv cւլ.eyı ՚ıı֊Zg t֊k\_ıj i Ab֊Zg| t֊tկi mıvgıMթ Kj ՚vY I DbwթtZ RbMY kixK նե, ՚թ RbկıթթZ cıııYZ նե GB Dթıtկի cՕZdj b NUvթZ mթղg GKgıv՝ ւԿղիv e՝e֊v| Zıv A֊ջbnZK Dbթb մvab Kti t֊tկi AMթıvıtK ՚ջZı Kti tZıjıvı Rb՝ ւԿղıvթK cՕquMgղ֊x Kiv cՕquRb| t֊tկi RbMYtK KթթıbթqıvıMi ւԿղիv Ges Dchթ՝ ՚թZv ARթbi cթıvı mgMՕնԿղիv e՝e֊vq \_vKtZ նե|
- S. **tbZZı.I mslMթbi և Yvej x, մRbկj Zv I MթelYv** th tKvb t֊tկi ւԿղիv Zvi RvxZı ՚ıaxb ıPՏı, մRbկj Zv, մıvslMıvıbK ՊgZv I tbZtZji և Yvej x յեKվtկ eyj օ c֊թթc| mgMՕ ւԿղիv e՝e֊v Ggb նե hvթZ tKej Z֊ AvııY bq, Dcjıı, յեթk-ıY, AbıvııRmıv, MթelYv I ՚ıaxb fıթe mZ֊vıvııvıv cթıւZ. և Yvej x յեKվk NUvթZ mթղg նե|

1996 mŷj Avl qvŷ j xM miKvi ŷgZvq Avmvi ci mgKvj xb wekŷi mŷ\_ mŷwZ i ŷvKŷi wekŷvi Dbqŷbi i aZ; bZbŷŷe Dcj wä Kiv nq| GKw ŷK i vŷŷq cŷqvRb tgUvŷbv, Aciw ŷK cŷ\_ exi Dbz ŷ`k, ŷj vi wekŷv e`e`vi Zj` chŷq wekŷvŷK Dbz Kivi cŷqvRbxqZv Acwivh`eŷj MY` Kiv nq| miKvi GKw hŷMvŷŷvMx wekŷvbxwZ cŷqŷbi j ŷŷ` 1996 mŷj 56 m`ŷm`i GKw RvZxq wekŷvbxwZ KŷvU MVb Kŷib| KŷvU 1997 mŷj i ŷmŷPŷŷ gvŷm Ppviŷ wiŷcvU`ŷck Kŷib| wiŷcvUŷ miKvi i Abŷgv`ŷbi Aŷcŷvq AvŷQ|



**cŷvŷvEi gj`vqb - 1**

**A) eŷ ubeŷPbx cŷkæ**

mŷwK DËi wŷŷ` Rgj-K Aŷŷi wŷŷK eŷvŷqZ Kiab| (D`vniY: Avcbvi ubeŷPZ DËi wK ntŷ GŷK  eŷvŷqZ Kiab)

1. msŷeavŷbi wŷZxq ŷvŷMi 17 bs AbŷPQŷ` Kx cŷŷŷ½ ej v ntŷŷQ?

  - K. MYZŷ; l gvbeŷaKvi cŷŷŷ½
  - L. RvZxqZvev` cŷŷŷ½
  - M. MYgŷx l meRbx wekŷv cŷŷŷ½
  - N. agŷŷ mnbkŷj Zv cŷŷŷ½

2. 1974 mŷb ŷKvbiU cŷKvŷKZ nq?

  - K. evsj v`ŷki msŷeavb
  - L. KŷivZ-G-Lŷv wekŷv Kŷgkb wiŷcvU`
  - M. gŷdR Dwi b wekŷv Kŷgkb wiŷcvU`
  - N. AŷŷŷxKvj xb wekŷv Kŷgkb wiŷcvU`

3. Kŷj x Rbm`u` mŷŷi Rb` ŷKvbiU cŷqvRbxq bq?

  - K. eŷgŷx wekŷv aviv cŷZŷ
  - L. gvbiŷK l KŷvqK kŷgi mgŷŷ
  - M. wekŷv e`e`v cŷqvMgŷxKi Y
  - N. Kŷs`vi, Avvŷvi l `ŷŷZi Aemvb NUvŷbv

4. ŷ`kŷcŷŷ l mŷŷMwi KZ; ej ŷZ Kx tevŷvq?

  - K. ŷ`kŷK ŷvj evmŷ
  - L. RvZxq msŷwZŷevŷa Dŷx n l qv
  - M. mKŷj i Avkv AvKv`ŷvŷi mŷ\_ GKvZŷ n l qv
  - N. Dcŷi i me, wj

**Av) msŷŷŷB DËi cŷkæ**

1. evsj v`ŷki msŷeavŷbi wŷZxq ŷvŷMi 17 bs AbŷPQŷ` Kx ej v ntŷŷQ?
2. msŷeavb Abŷŷvŷx i vŷŷŷq gj-bwŷZ, ŷj v Kx?
3. evsj v`ŷki wekŷvi cŷŷv j ŷŷ` Kx?
4. cŷqvMgŷx A\_ŷŷwZK AMŷŷwZi Abŷŷŷj wekŷv ej ŷZ Kx tevŷvq?



mŷwK DËi: A) 1| M, 2| L, 3| N, 4| N|





מכילוי קבועים ומזמורים		
מספר		
22+		D"פ מכילוי
21	16	ג'ג'ג
20	15	מז"ק
19	14	(מג"ב)
18	13	מז"ק (צ"מ)
17	12	D"פ ג'ג'ג
16	11	
15	10	נ"ב
14	9	
13	8	מב"ב נ"ב
12	7	
11	6	צ"מ
10	5	
9	4	
8	3	
7	2	
6	1	
5		צ"מ-צ"מ
4		
3		
eqm	ת"כ	

**דרם: נקבי תמ"ק וי"ג ממ"ב צ"מ**

D"פ ג'ג'ג ת"י מכילוי גל"ב חי"ג מזמור ת"ג ר מכילוי א"ש ומת"י ל"ב נ"ב, ג'ג'ג ת"י ב"ב ז"ב ג"ב ת"י מכילוי צ"מ ז"ב מ"ב י"ג D"פ ג'ג'ג ת"ג ר ב"ב ג"ב מ"ג | D"פ ג'ג'ג ת"ג ר ג"ב ל' ז"ב ת"כ ז"ב צ"מ ז"ב ק"ב נ"ב | צ"מ 98% D"פ ג'ג'ג ת"ג ר ב"ב מ"ב י"ג | ג"ב ל' ז"ב ת"כ ז"ב מכילוי D"פ ג'ג'ג ת"ג ר ז"ב א"ב ל' ז"ב א"ב צ"מ ז"ב צ"מ ז"ב ק"ב נ"ב:

- ז"ב ק"ב ת"ג ר א"ב ג'ג'ג ע"ב ז"ב ת"י מ"ב ג"ב ל' ז"ב ת"כ ז"ב | צ"מ ז"ב |
- מ"ב מ"ב ת"ג ר, צ"מ מ"ב מ"ב מ"ב ת"ג ר ב"ב D"פ ג'ג'ג ק"ב ל"ב ז"ב |

**D"פ מכילוי**

D"פ מכילוי מ"ב י"ג צ"מ ע"ב ת"ג ז"ב, א"ב (3 ע"ב מז"ק צ"מ + 2 ע"ב ג'ג'ג מ"ב מ"ב) א"ב ע"ב (4 ע"ב מז"ק א"ב מ"ב + 1 ע"ב ג'ג'ג מ"ב מ"ב) | ג ז"ב ג"ב ע"ב מ"ב מ"ב | מ"ב ר"ב א"ב ז"ב ב"ב ז"ב ה"ב ז"ב ג"ב ע"ב 2 ע"ב ג"ב 3 ע"ב מ"ב צ"מ ר"ב נ"ב | D"פ מכילוי צ"מ ז"ב ת"ג ר מ"ב מ"ב מ"ב ת"ג ר ג"ב ז"ב ז"ב | ג ח"ב ת"כ מ"ב י"ג | ת"ג מ"ב י"ג





### erjir`k gj`iqb- 2

#### A) erjir`k ibe`Pbx c`kæ

m`WK D`Ei ir`k Rgj-K A`ji`U`K e`F`iqZ Kiab | (D`vniY: Avcbvi ir`k PZ D`Ei`U K nj G`K  e`F`iqZ Kiab)

- erjir`k i`ki ir`k`jv e`e`vq KquU ir`k`jvaviv Av`Q?  
K. GK`uU  
L. `B`uU  
M. wZ`buU  
N. Pvi`uU
- erjir`k KZ eQi ch`S`ir`k`jv eva`Zigj-K?  
K. 10 eQi  
L. 12 eQi  
M. 14 eQi  
N. 16 eQi
- gv`imv ir`k`jvi tKvb `li`u mvaviY ir`k`jvi DPP gva`igK `k`i i mgZ`j`?  
K. `vL`j  
L. d`vR`j  
M. Avij`g  
N. K`v`igj
- t`fiv`Kk`bij ir`k`jv e`e`vq w`t`c`igv tKv`tm`e`f`w`Z`P` thv`M`Zv`Kx?  
K. 5g t`k`Yx`c`vk  
L. 8g t`k`Yx`c`vk  
M. gva`igK`c`vk  
N. DPP gva`igK`c`vk

#### Av) m`sv`j`B D`Ei`c`kæ

- gva`igK ir`k`jvi Dc`li`\_`tjv`Kx? c`Z`K`u`i` tgqv` D`tj`L` Kiab |
- gv`imv ir`k`jvi `li`\_`tjvi` D`tj`L` Kiab |
- c`Z`igK ir`k`jvi`\_`i`æZ`c`Y`Q` K`\_`tjvi` D`tj`L` Kiab |



#### m`WK D`Ei

A) 1 | M, 2 | K, 3 | L, 4 | M |

**cW 3**

**ւկղն շկմբ I e՛e՛ւււբն**

**Dփիկ՛**

GB cW փիկI Aւււբ —

- ◆ evsj ւփֿ փիկի ւկղն շկմբ Kւււտգն e՛ւL՛ն KիփZ cւիփեբ Ges
- ◆ evsj ւփֿ փիկի ւկղն շկմբ Kւււտգնի միփֿ Abփֿ փիկի ւկղն շկմբ Kւււտգնի cւ\_R՛՛ ււփֿ R KիփZ cւիփեբ|

evsj ւփֿ փիկի Rւււտգն ւկղն e՛e՛ւււբն մմեR շկմբ I cւիււիյ բնի մփֿP ղգZն I ՝ււղZ; ւկղն գճյւյ ղգի Dci b՛ւ՛ւլ ւկղնգճյւյ գճյւյ ղգի ւբեփն շկմբ| Zփֿ A\_՞msւււճի ւելզմգփնի ւբեփն շկմբ գճյւյ ղգի միււբ| մգ՛ւ՛ւււ Z ւելզK ւմxւճի գճյւյ ղգի Mւււտգն ղգի ւկղն գճյւյ գ ւկղնի միփֿ msւււո՞ հւեZւղ Aւճի գճյւյ գ ւելզեյ xi I մյււն Kփի ւփֿK| ւկղն գճյւյ ղգ GKւււ cւի Kի բնի փիւ Aճիփֿ iփֿQ հն գճյւյ ղգի Aւլ Zւււտգն ms՛ւււմգփնի փիկKZ.cճի մգփնի cւի exղյ Kփի Ges cւի Kի բնի գճյւյ գ I cւի Kի բնի Kւղկփի միփֿ փիււփիււ մւււբ Kփի |

շկմբմբK մյփֿւււ Rb՛՛ մգMոււկղն e՛e՛ւււբն ՝ււլ շկմբ Aսփֿ փիւ Kիւ նփֿQ - c՞ււղK I Mյււկղն ւեփիւ Ges գւաւղK I D՛P ւկղն ւեփիւ| ւեփիւ Aւա՛ Bi, Aւււ ՝ւղZկււււ Z c՞ւււււ I փիկMZ c՞ւււււ փիկ՝ ղգ շիփֿ ւկղն գճյւյ գ KZR.Mւււտգն bւււ Z I Kւիւղգ eւ՛եւղբ Kփի ւփֿK| G\_տյւի մսւղիւ cւիււււ ււփֿP c՞ււււ Kիւ նյ |

**c՞ււղK ւկղն Aւա՛ Bi**

ւկղն գճյւյ գ KZR.Mւււտգն c՞ււղK ւկղն մսւււճի bւււ Zգյւյ v Kւիւրի Kիւ GB Aւա՛ Bփի Kիւր| Zփֿ AփֿK մգգ GB Aւա՛ Bi ւկղն մxւււ KՉ Lմու bւււ Zգյւյ c՞ւղբ I Pուճի Kիփֿ e՛ււււ փիկի գճյւյ ղգի ւբKւ մգւււի Kի Kփի ւփֿK| GB Aւա՛ Bփի ՝ււղZ; նփֿv:

1. փիւյ c՞ււղK ւկղն Aւււմ, ւււ ւկղն Aւււմ, տյւփֿ KգփZ KգRZփ, Kգփիւ I c՞ււղK ւե՛ւյ ղգի ւկղն մxւււ KՉ շկմբ, e՛e՛ւււբն I cւի ՝կ՞;
2. c՞ււղK ւկղն մxւււ KՉ bւււ Z c՞ւղբ I eւ՛եւղբ մxւււ K՞ գճյւյ ղգի cիւղկ՞ ււ;
3. c՞ււղK ւկղն Dbղբ cճի c՞ւղբ I eւ՛եւղբ;
4. Aւա՛ Bփի Aւււ ւեփիւ փիւ Aւււմ I c՞ււււ փիւ շկմբ, cւի ՝կR I Ab՛ււ՛ Kգփիւ Ges ւկղն KMփֿ փիկMZ cճի փիկի e՛e՛ւււբն;
5. c՞ււղK cճիղյ Bբւ÷ււDU I b՛ււկւյ GKւփWգն di c՞ււղիւ GWKKb-Gi Dbղբ;
6. c՞ււղK ւկղնի eւփֿRU c՞ւղբ I eիւ՛ի KZ.Aփֿ P մ՞enւ ււււճZKիY|
7. մփֿււ Aւա՛ Bփի Aւււ bb K՛ւււ KգRZփ, Kգփիւ ււփֿM cփֿ ււււ I e՛յ xi e՛e՛ւււիY|

**gva`ngK I D`P ukŷv Ava`Bi**

gva`ngK I D`P ukŷv Ava`Bi gva`ngK I D`P ukŷv cŷvmb Ges Z`viŷKi Rb` ukŷv gšŷvj ŷqi ubKU `vqx \_vŷK| GB Ava`Bi wefvMiq Avdm, tRjv Avdm, gnwe`vj q, D`P we`vj q Ges gv`tmvngŷni mnŷhMzvq cŷvmbK Kvŷŷej x cwi Pvj bv Kŷi \_vŷK| GB Ava`Bŷi i cŷvb gnvcwi Pvj K| Zuŷ KvR mŷZvŷte m`ubŷKivi Rb` ZŷK cwi Pvj K (gva`ngK ukŷv), cwi Pvj K (D`P ukŷv), cwi Pvj K (cŷkŷY) Ges cwi Pvj K (cwi Kí bv I Dbqŷ) mn Ab`vb` wefvbŷchŷqi KgŷZP I KgŷvixMY mnŷhMzv cŷvb Kŷi \_vŷKb| GB Ava`Bŷi i KvR nj miKvix gva`ngK `ŷ, Kŷj R I gv`tmvngŷ cwi Pvj bv Kiv| G Qvovl GB Ava`Bi temiKvix gva`ngK `ŷ, Kŷj R I gv`tmvngŷK wevea cŷvi gÁjmn Zvŷ`i ukŷK Kgŷvix`i teZb-Abŷvbl cŷvb Kŷi \_vŷK| gva`ngK I D`P ukŷv mŷmŷšDbqŷ cŷkí I GB Ava`Bi ev`evqŷ Kŷi \_vŷK| GLvŷb Dŷj - L Kiv cŷqvRb th miKvix `ŷ I Kŷj R, ŷj vŷK KŷqKwŷ tŷŷŷ GB Ava`Bŷi i ubqšŷ tgŷb Pj ŷZ nq| ubeŷPZ MfvŷŷewW-Gi gva`ng temiKvix `ŷ I Kŷj Rmgn cwi Pvj Z nq|

**KwiMwi ukŷv Ava`Bi**

KwiMwi ukŷv Ava`Bi KwiMwi ukŷv cwi Pvj bvi Rb` ukŷv gšŷvj ŷqi ubKU `vqx \_vŷK| GB Ava`Bi t`ŷki cij ŷUKwbK, gŷbvŷUKwbK I tŷvŷKkbvj Bbw`wUDUmgŷni cŷvmb I Z`viŷKi KvR Kŷi \_vŷK|

**d`wuj wR cwi`Bi**

ukŷv gšŷvj ŷqi Avl Zvaxb mKj cŷvi cZŷvR m`uv`b Ges wefvbŷ febmngŷni iŷŷvŷŷŷ Gi cŷvb KvR| GKrb cŷvb cŷKŷkj x KŷqKwŷ AvÁjv K Kvŷŷŷ ŷqi gva`ng ukŷv Ava`Bŷi i Avl Zvŷŷ mKj Kvŷŷŷ q I ukŷv cŷZŷvŷbi feb ubgŷŷ I iŷŷvŷŷŷ Kŷi \_vŷKb| miKvix Abŷvŷb ubgŷŷe` temiKvix ukŷv cŷZŷvŷbi febv` I GB cwi`Bi KZŷ.ubgŷŷ nq|

**AvwU I Bbŷ`úKkb cwi`Bi**

temiKvix gva`ngK I Kŷj R chŷŷŷ ukŷv cŷZŷvbmngŷni Avwŷ ŷj bŷ`ŷbi wnmve ubixŷv Kiv GB cwi`Bŷi i cŷvb KvR| GKrb cwi Pvj K GB cŷZŷvŷbi cŷvb|

Ava`Bi Ges cwi`Bi ŷjv Qvovl ukQyAvav`ŷqZkvmmZ cŷZŷvŷ evsj v`ŷki ukŷv cwi Pvj bvi tŷŷŷ ŷ, iæ`wqZj; cij b KiŷQ| G ŷjv mŷŷŷŷ ewŷŷ nŷjv:

- **wekte`vj q gÁjx Kugkb** – Gi cŷvb `wqZj; nŷjv wekte`vj q ŷjv ukŷv Pwv`v ubiŷŷ Ges Pwv`vbŷvqx ukŷv i Dbqŷŷi Rb` cwi Kí bv cŷqŷ Abŷŷw`Z cŷkŷi i ev`evqŷ I gj`vqŷ|
- **gva`ngK I D`P gva`ngK ukŷv tevW** – t`ŷk 5wU gva`ngK I D`P gva`ngK ukŷv tevW©AvŷQ| G ŷjv gva`ngK I D`P gva`ngK ukŷv cŷZŷvŷ ŷjv ukŷv welqK welq ubqšŷ Kŷi Ges GmGmm I GBPGmm ciŷŷŷi `wqZj; cij b Kŷi |

ḡ Ae GWḡKkb

- **KwiMni ḡḡv teW** – GB cĀZōvb, cij tUKġbK, gḡbvtUKġbK, eḡĒg-j-K ḡḡv cĀZōvbmgḡni ḡḡv mspvšl̄elq, tjv ḡbqšY Kḡi |
- **gv`ḡmv ḡḡv teW** – gv`ḡmv ḡḡv mspvšl̄`ḡqZj; cij b Kḡi ḡḡK |
- **RvZxq ḡḡvḡg I cv`cYK teW** – gvaḡgK ḡi chšl̄ cĀZōvb, tjvi ḡḡvḡg, cv`mḡP cḡqb Ges Z`vbḡḡḡi cv`cYK cḡqb, gY I ḡZiḡYi KvR mḡḡv`b Kḡi ḡḡK |

G, tjv Qvovl mshY Ges ḡḡkl aiḡbi RvZxq cĀZōvb iḡḡ0 | thgb- bvtqg, e`vbḡBm |

- **NAEM** (b`vkbvj GKvḡWgx di GWḡKkbvj g`ḡbRg`vU) – Gi ḡḡqZj; nḡjv ḡḡv cġvmb, cwi Kḡi bv Ges e`e`vcbv ḡelḡḡ ḡḡv cġvmbḡbi EaYzb KgRZḡ`i PvkZxiceḡ Ges PvkZxKujxb cġḡḡY cġvb Ges Gme tḡḡḡ MḡelYv cwi Pj bv | ḡḡmGm (ḡḡv) K`vWviḡ`i dvDḡŪkb tUḡbsl̄ GLvḡb t`qv nq |
- **BANBEIS** (evsj ḡ`k eYiv Ae GWḡKkbvj Bbdiḡkb GŪ ÷ḡUḡmUKm) – Gi cġvb ḡḡqZj; nḡjv ḡḡvḡj-K Z` msl̄ḡ, msKj b, gY I cḡvi Yv |

ḡḡ 2: evsj ḡ`ḡi ḡḡv cġvmb Kḡḡḡv

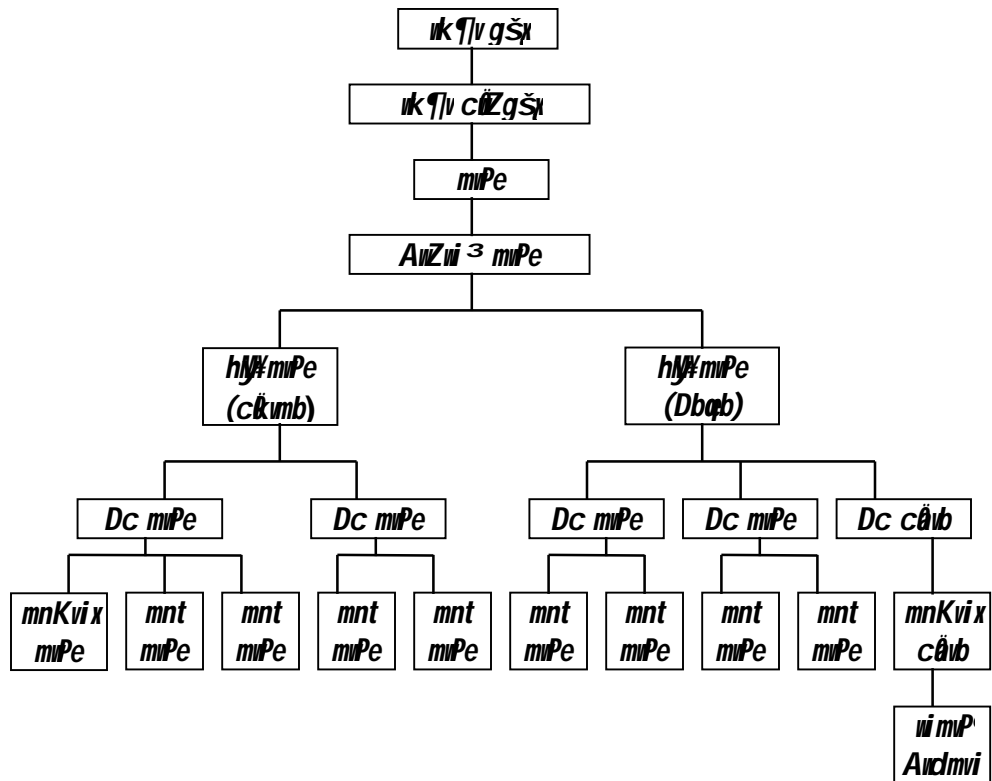



### civivi gj`iqb - 3

#### A) eü ubePbx ckae

mivK DEi ubt`Rgj-K AjiuUK eEviqZ Kiab | (D`vniY t Avcbvi ubePZ DEiuU  
K ntj GtK (K) eEviqZ Kiab)

1. ukjlv gšyij tqi A\_ m=úukZ mel qmgtni ubePbx cávb tk?  
K. A\_ gšy  
L. ukjlv gšy  
M. ukjlv miPe  
N. msm`xq ukjlv Kuglji mfvciZ
2. tkvbuU Avav`iqZkvmZ cáZövb bq?  
K. AvvU GÜ BÝtcKkb cwi`Bi  
L. iekje`ij q gÄjx Kugkb  
M. gva`igK I D`P gva`igK ukjlv tevW©  
N. RvZxq ukjlvµg I civ`cyK tevW©
3. tkvbuU NAEM-Gi`viqtZji gta` cti bv?  
K. veimGm (ukjlv) dvDtÜkb tUlbs cÜvb  
L. ukjlv KgRZMti Yi PvkziKvj xb cákqjY cÜvb  
M. ukjlv gj-K Mtel Yv cwi Pvj bv  
N. ukjlv gj-K Z\_` msmth I mskj b
4. gva`igK I D`P ukjlv m=úukZ cákí ev`éiqb Kti tkvbuU?  
K. ukjlv gšyij q  
L. gva`igK I D`P ukjlv Avva`Bi  
M. iekje`ij q gÄjx Kugkb  
N. cwi Kí bv tkv
5. gva`igK I D`P ukjlv Avva`Bti i cwi Pvj tki msL`v KZ?  
K. `BRb  
L. vZbRb  
M. PviRb  
N. cWRb

#### Av) msvjB DEi ckae

1. cá`igK ukjlv Avva`Bti i KtqkuU cávb`viqtZji DtiL Kiab |
2. gva`igK I D`P ukjlv Avva`Bti i KtqkuU cávb Kvtrí DtiL Kiab |
3. KtqkuU Avav`iqZkvmZ cáZövtbi msvjB cwi vPvZ v`b |
4. d`vniuj uJR cwi`Bti i cávb KvR\_ tji v Kx?
5. vvtqg uk ai tbi cáZövb? Gi`viqtZji Kx?



#### mivK DEi

A) 1 | M, 2 | K, 3 | N, 4 | L, 5 | M |



### პირსიჯიყბ

#### A) ეუ იბეიპხ ციკე

მიუკ დეი იბეიჯიკ აქიიუქ ექვიკი კიბ | (D`vniY t Arcbvi იბეიპზ დეიუ  
K ntj GtK (K) ექვიკი კიბ)

1. ევსი იქიკ ციუკი იქვი ევაჯიკი აიბი ციკი ნი ტიბი მიქი?  
 K. 1972  
 L. 1974  
 M. 1990  
 N. 1992
2. გვიმი იქვიავიკი კიუი იქი იქი?  
 K. იუ  
 L. იზიუ  
 M. პიუ  
 N. ციუ
3. მიქიუიუიუი იქი ტიბი იქი იქვი ცივი კი ნი?  
 K. იქიუი მიუი  
 L. ციუკი  
 M. იბგვიიუკი  
 N. გვიიუკი
4. იქიქვი I იქიქვიეი კიქი იქვი იქი ტიბიუ?  
 K. იბგვიიუკი  
 L. გვიიუკი  
 M. D`P გვიიუკი  
 N. Dcti i me,ij
5. იქვი გსიქი იქი იბეიქი ცივი ტი?  
 K. ცივიგსი  
 L. msm`xq Kugui mfvuz  
 M. იქვიგსი  
 N. იქვი მიე
6. მი კვი გვიმიგვი ციუი პიქი ბი იქვი ცივი ბი კი ტიბიუ?  
 K. გვიიუკი I D`P იქვი აიბი  
 L. გვიმი იქვი ტევი  
 M. ეიბიბი  
 N. გვიიუკი I D`P იქვი ტევი



**Av) iPbvj-K cka**

1. ersjv`tki ukvivi j`q` I Df`k`vej eY`v Kiab|
2. ersjv`tki ukvivi Kvitgvi c`vn wP` AsKb Kiab Ges Gi ,iaZcY`  
w`K`tv eY`v Kiab|
3. ersjv`tki ukvivi ckvmb I e`e`vcbvi t`q`f` gS`vj q I Gi Aarb`I  
Ava`B`ii ,iaZjeY`v Kiab|



**mVK D`i**

A) 1| M, 2| N, 3| L, 4| N, 5| M, 6| K|

**fviþZi ukŕŕve'e'v**

**fvgKv**

1947 mvtj `vaxbZv jvtfi ci fviþZi RvZxq ukŕŕve'e'v Mto tZvj vi j þŕŕ`  
e'vcK Df`vM MðY Kiv nq| hþMi cðqvRb, mgvþRi Pwn`v Ges mgvR weeZþbi  
mvt\_ mþwZ i ŕŕv Kþi ukŕŕvi ms`vi I cþMŕþbi j þŕŕ` AþbK\_ þjv ukŕŕv Kvgkb  
MwZ nq|

ZvivPv Kvguŕi wþcvþU©(1948-49) meðŕg 20 ermi tgqv`x ukŕŕv Dbqþ  
cwi Kíbvri ceŕŕvl cvl qv hvq| GB Kvguŕ 5 ermtii cðwK, 3 ermtii wþge  
gva'wgK Ges 4 ermtii gva'wgK ukŕŕv A\_ŕ wekte`vj þq cðetki Rb` 12  
ermtii ukŕŕv cþwZi mþwmi k Kþi b| GB Kvguŕ eúgþx cvV`þg Ges GKwŕ gvŕ  
mgvþB cixŕŕvi K\_vl etj b| GB mgþq W. ivavKþði tbZþZ; MwZ wekte`vj q  
Kvgkb fviþZ gva'wgK ukŕŕvþKB `þŕZg Askifc AvL`v t`b, hvi dj kðwZþZ  
1952-53 mþb W. j ŕŕY`ŕgx gþwþj qþi tbZþZ; gva'wgK ukŕŕv Kvgkb MwZ  
nq| Gme Kvguŕ mþúþK©ejv hvq þh, G\_ þjv mþwmi k Kþi Qb wevQbŕvþe, wevŕbæ  
weŕq I wevŕbæ`li mþúþK©Ges Gme tRiovZwþj w þq RvZxq ukŕŕve'e'v Mto  
tZvjv mþe nqub| GB Amvdj þK 0`\_ŕxb fvŕvq `ŕKvi Kþi B 1966 mþb  
meŕŕvi Zxq ukŕŕv Kvgkb A\_ŕ tKvWwmi Kvgkb MVb Kiv nq| ukŕŕvi meðþi  
Dbqþ mvaþb GB Kvgkþbi mþŕwŕZ AwfgZ AZ`ŕcŕksmbvq|

GB BDibþU AvayþK fviþZi ukŕŕve'e'vi Dci AvþjvKcvZ Kþi wZbuŕ cvV  
Dc`rcb Kiv nþqþQ|

- cvV - 1 RvZxq ukŕŕvþwZ, ukŕŕvi j ŕŕ` I Dþŕk`
- cvV - 2 ukŕŕvi KvŕþgvMZ ifc
- cvV - 3 ukŕŕv cðvmb I e'e'rcbv

**cW 1**

**RvZxq uk`qivbwnZ, uk`qivi j`q` I Df`ik`**

**Df`ik`**

GB cW tk`l Avciw —

- ◆ fvi`zi RvZxq uk`qivbwnZ eY`v Ki`z cvi`eb;
- ◆ fvi`zi uk`qivi j`q` I Df`ik`vej eY`v Ki`z cvi`eb Ges
- ◆ uk`qivi j`q` I Df`ik`vej wbaft`yi t`qf` RvZxq gj-bwnZi c`Zdj b mbv<sup>3</sup> Ki`z cvi`eb|

**RvZxq uk`qivbwnZ**

tKvVmi Kugk`bi mgvni`tki wfu`E`z 1968 mt`j tK``iq gšymfvq RvZxq uk`qivbwnZ tNvlyv Kiv nq| 17wU `dvi GB tNvlyvi gta` th me ,iaZcy` w`K,`tjvi Df`j - L Kiv ntq`Q Zv nj :

1. msueat`bi wbt`R Abynt`i 14 eQi eqm chSf meRbxb, A%ZubK Ges eva`Zvgj-K uk`qivi bwnZ Kivh`Ri Kiv|
2. RvZ, ag,`eY,`Av`Aj K I mvgvni`RK `elg` wbu`ek`l mKt`ji Rb` uk`qivi mgvb m`thvM m`w` Kiv|
3. bvi`x uk`qiv, m`v`q`i`Zv I eq`-` uk`qivi Dci ,iaZj Av`ivc Kiv Ges correspondence course c`Pj b Kiv (we`tkl Kti kigK-Kl.Kt` i Rb`)|
4. RvZxq msnwZ I ms`wZi weKvk mva`tbi j`q` wZb-fvlv m`f`i c`q`vM Kiv| A`\_f` `z` `f`i uk`qivq Avn`x AA`tj uk`qivxq fvlv nte – gvZfvlv, Bst`i`R I un`x Ges un`x AA`tj uk`qivxq fvlv nte – un`x, Bst`i`R Ges Ab` GKwU Av`v`K fvi`Zxq fvlv (m`e` ntj GKwU `w`qY fvi`Zxq fvlv)|
5. Kj`vYgj-K I Kg`Av`f`ÁZvq eva`Zvgj-K fite mKj uk`qiv`f AskM`hY Kiv|
6. uk`qivi gv`bv`q`tbi j`q` Dch`y` uk`qivK wbt`q`vM I c`k`qY c`v`b Ges Dch`y` teZb, mvgvni`RK m`y`b I tckvMZ `v`x`bZv wbu`oZ Kiv|
7. A`\_w`v`ZK Db`q`b Zj`v`S`Z Kivi j`q` we`Avb, MvYZ, c`h`y` I M`te`lyvi m`thvM m`w` Kiv|
8. uk`qivi Rb` mgtch`q RvZxq Av`tqi 6 kZvsk eiv`i Kiv|

**uk`qivi j`q` I Df`ik`**

fvi`zi uk`qivi j`q` I Df`ik`vej x Dcwi Duj wLwZ RvZxq uk`qivbwnZi Dci wfu`E` KtiB c`v`xZ ntq`Q| tK``iq uk`qiv gšy`v`q uk`qiv e`e`vi c`p`M`tbi j`q` 1985 mt`j Challenge of Education – A Policy Perspective tNvlyvq uk`qivi j`q` I Df`ik`vej x thfite weaZ Kti`Q Zv wbt`g`eZ`tj aiv nj :

1. tgav I gb#bi mKj t#t# beZi Á#bi ueKvk mrvab |
2. Dbq#b I AM#uZi c#\_ ueivmRZ mgm'vej x mgvav#bi Rb" c#qvRbxq Ávb I `#Zvi ueKvk mrvab |
3. t#ŠZ I mvgvRK cvi#tek m#ú#K© uk#v\_# Dcjwä ueKv#k mnvqZvKiY |
4. e'ir#i Av\_#mvgvRK ~'Q>, thvM'Zv I mRbkxj Zv ueKv#ki j#t# –
  - e'ir#t#j# ^`uK, gvbumK I b#`ubK u' Kmg#ni ueKvk mrvab,
  - MYZvŠK, `b#ZK I Ava"uZ#K gj-#eva Ges `eÁvbK `#ófi#i cvi #b,
  - ARvbn cvi u' uZ tgvK#ej v I D"te#bi Rb" AvZ#ek#m RvM#ZKiY,
  - c#K#ZK, mvgvRK, A\_#b#ZK, mvs`uZK I ch#M#Z cvi#tek m#ú#K#m#PZbZv m#óKiY |
  - K#Vvi cvi k# Ges k#gi gh# v m#ú#K© Ab#k#j `#ófi#i D#b# mrvab,
  - ag#bi#c#Zv I mvgvRK b'vq#ePv#i b#uZi c#Z ub#e# ZKiY,
  - t`#ki AL#Zv, m#yb I AM#uZi ~`#D#ta#Z#j aivi Rb" ub#e# ZKiY Ges AvŠR#ZK mgt#vZvi Dbq#b |
5. uevfb#e uk#Yxq ue#tqi Z#; Z\_ I Á#bi ueKvk mrvab Ges fvlv I thvM#thv#Mi t#t# `bc# AR#bi c#kvcvuk tLjvajv I Avtgv` c#gvt`i c#Z Abj#M m#óKiY |
6. t`#ki AM#uZi aviv I Kg#t#i m#thv#Mi m#\_ mvgAm" eRvq ti#L uk#v\_#`i c#qvRbxq Ávb I `#Zv u' t# thvM'Zv AR#b mnvqZvKiY |
7. uk#vi ue`ri Ges gv#bv#bKiY hv#Z ag, eY, gZv`k, A\_#b#ZK Ae`v ub#e#k#l b#v# c#j# c#Z`#KB m#e#P ueKv#ki m#thvM cvq |
8. mnbkxj Zv I A#b'i gZvgt#Zi c#Z k#v#kxj n#qvi ,ia#; Ab#ve#b uk#v\_#`i mnvqZvKiY
9. uk#vi m#\_ mgvt#ri thvM# ~vcb |



### cvVvEi gj`vqb- 1

#### A) eú ubePbx cĕæ

mWVK DĒi vb`Rgj-K AŋiUŋK eĒvqZ Kiab | (D`vniY: Avcbvi ubePZ DĒiU K ntj GtK Ⓚ eĒvqZ Kiab)

1. tKvb wiŋcvU<sup>©</sup>meĒlg eúgĒx cvWµg Ges GKU gvĪ mgvB cixŋvi mgvvi k cŏvb Kŋi?  
 K. Zviv PvĪ KvgU wiŋcvU<sup>©</sup>  
 L. ivavKò.Y Kvgkb wiŋcvU<sup>©</sup>  
 M. gyvuj qvi Kvgkb wiŋcvU<sup>©</sup>  
 N. tKvVix Kvgkb wiŋcvU<sup>©</sup>
  
2. RvZxq msnWZ I ms`wzi meKvk mvaŋbi jŋŋ` fviŋzi RvZxq vKŋvbWZŋZ tKvbU Di iaz; Avŋvc Kiv nq?  
 K. meRbxb vKŋv KvRi Kiŋyi Di  
 L. mKŋj i Rb` vKŋvi mgvb mŋhM mWpKiŋyi Di  
 M. RvZ, ag<sup>©</sup>eY<sup>©</sup>AvĀvj K I mgvRK `elg` vbiŋbi Di  
 N. wZb-fvlv mĪ i cŏqvMKiŋyi Di
  
3. wZb-fvlv mĪ Abŋvqx Avn>`x AĀŋj i vKŋYxq fvlv nŋe tKvbU?  
 K. BŋiWR, vn>`x I Ab` GKU AvvŋK fvlv  
 L. gvZfvlv, BŋiWR I vn>`x  
 M. gvZfvlv, vn>`x I Ab` GKU `vŋY fvi Zxq fvlv  
 N. gvZfvlv, BŋiWR I Ab` GKU `vŋY fvi Zxq fvlv

#### Av) msWŋB DĒi cĕæ

1. fviŋzi RvZxq vKŋvbWZi cvU iazcY<sup>©</sup> dvi DŋjL Kiab |
2. wZb-fvlv mĪ vK Zv e`vL`v Kiab |
3. vKŋvi cĕvb 5Uj ŋŋ` I Dŋk` DŋjL Kiab |



#### mWVK DĒi

A) 1 | K, 2 | N, 3 | L |



**¶1: fviZi wk¶v KwWgv**

	শিক্ষিত ব্যক্তি	Øv`k tkYx DaY`tkYx	mæZK I mæZtkvEi
মাতৃশিক্ষিত		GKv`k I Øv`k tkYx	D`P ga`igK
		beg — `kg tkYx Aóg — `kg tkYx	wbga`igK
		Iô tkYx — Aóg tkYx cÂg tkYx — mBg tkYx	D`P cØ`igK
প্রাথমিক শিক্ষিত		cØ`g tkYx — cÂg tkYx cØ`g tkYx — PZz`tkYx	wbga`igK

wbga`igK `fi i tkl cØ`s, A\_¶ 10 eQ`ii wk¶vi tktl AbjZ nte cØ`g mvaviY cix¶v (tmKÊvix `z mWUØ`tkU cix¶v) | `k eQie`vcx GB wk¶v nte mvaviY wk¶v, tKvb we`tklxKiY \_vKte bv|

• **D`P gva`igK wk¶v**

we`vj`qi tkl `fi itqtQ `B eQ`ii D`P gva`igK wk¶v, A\_¶ GLv`b wk¶v\_¶v GKv`k I Øv`k tkYx ch`Aa`qb Kti | GB `fi we`tkl cv`vi mPbv Kiv ntj I Pig we`tklxKiY Kiv nq bv| D`P gva`igK wk¶v tktl nvqvi tmKÊvix `z mWUØ`tkU cix¶v MhY Kiv nq|

• **D`P wk¶v ev wekte`vj q wk¶vi `fi**

wekte`vj q wk¶vi `fi itqtQ wZb ev Z`ZvnaK eQ`ii cØ`g wWwMØ`li (e`v`Pj i wWwMØ`li) Ges Z`jaY`2 eQ`ii wØZxq wWwMØ`li ev gv÷vm`wWwMØ`li | GB `fi mvaviY wk¶v Qvovl bvbv ait`bi cY`mg`ti wKsev AvsukK mg`ti wk¶v itqtQ | D`P `fi i wk¶v ch`q 4wU D:gy wekte`vj q Ges 45wU Ab`vb` wekte`vj q we`fbæait`bi cØ`g GKkU wWwMØ`li vgv tkvm`cwi Pvj bv Kti \_v`tk | 1986 mtj w`j - x`Z RvZxq ch`q `mcZ Indira Gandhi National Open University (IGNOU) cØ`g 150wU Av`w`j K tKb`i mrvqZvq `i wk¶vY c`xwZ`Z we`fbæ we`l`qi wWwMØ`li vgv, wWwMØ`li tkvm`cwi Pvj bv Kti \_v`tk |

ᄡ Ae GWKkb

• **KwiMwi ukŕŕv**

ivR" Kwimwi ukŕŕv tevW©mwiU@t#KU, wWtcugv I wWwM0 ch#qi newfbœait#bi Kwimwi ukŕŕv tKvm©cwiPvj bv Kti| ukí tU#bs tevW© cuj tUK#bK I ia`vj Bbw=UUDU, t#v eù ait#bi tUW Ges tmt#Uwmiqvj tKvm©cwiPvj bv Kti| `k eQtii ᄡ tKvm©k#I GB tKvm©t#v#Z fivZ#nI qv hvq|

• **I#cb ᄡ**

1979 m#b 0#m>U#j tevW©Ae tmt#K0vix GWKkb0 KZR 0Db# we`vj q0 c0Z0 Kiv nq| 1990 m#b fviZ miKvi GKwU tiR#j k#bi gva`tg RivZxq Db# ᄡt#K gva`ngK I D"P gva`ngK ch#q tKvm©cwiPvj bv, cixŕŕv MhY I mwiU@t#KU c0v#bi ŕŕgZv c0vb Kti| 1992-93 ukŕŕve#I©mviv fvi#Zi 2.5 j#ŕŕi I AwaK ukŕŕv\_ŕGB ᄡ i newfbœ#Kv#m©FivZ#nq|





### cvWvEi gj`vqb - 2

#### A) eU ubePbx cKæ

mWVK DEi w`Rgj-K AqiuWtK eEvmqZ Kiab | (D`vniY: Avcbri ubePZ DEiuW K ntj GtK (K) eEvmqZ Kiab)

1. wkqv i wekixKiY tKvb `fi iiaeq?
  - K. wbgvga`vgK `fi
  - L. D`P gva`vgK `fi
  - M. wekpe`'vj q `fi
  - N. Kvi Mvi wkqv `fi
  
2. e`vtpj i wvWvM`li KZ eQi tgqv`x?
  - K. `B eQi
  - L. wZb eQi
  - M. Pvi eQi
  - N. cvP eQi
  
3. tKvbuW mWVK bq?
  - K. cU`vgK wkqv `fi i `BvW Dc`li itqtQ
  - L. gva`vgK wkqv `fi i `BvW Dc`li itqtQ
  - M. cU`vgK wkqv c`jv Qq eQi eqtm`i iiaeq
  - N. wkqv i gj`vqZj tK`xq miKv`i i Dci b`i
  
4. Bw`iv MvUx b`vkbyj I tcb BDwbvmmWv tKvb aitbi tKvm`cwi Pvj bv Kti?
  - K. wWtc- vgv I wvWvM`tKvm`
  - L. GmGmwm I GBPGmwm tKvm`
  - M. tUW I tm`pUvvi qvj tKvm`
  - N. Dc`i i me`vj

#### Av) msuqjB DEi cKæ

1. gva`vgK wkqv `li KvWrtgvi msuqjB eYv`v w`b |
2. D`P wkqv `li KvWrtgvi msuqjB eYv`v w`b |
3. D:gy` wkqv e`e`v m`u`tk`qv Rv`bb Zv D`j L Kiab |



#### mWVK DEi

A) 1 | L, 2 | L, 3 | N, 4 | K |

**cW 3**

**ukŋv cǵvmb I e'e'vcbv**

**Dǵik"**

GB cW tkǵI Avcb —

- ◆ fviǵZi ukŋv cǵvmb tkǵ`ǵ Ges ivR" miKvǵii fvgKv vbYǵ KiǵZ cviǵeb Ges
- ◆ ukŋv cǵvmb I e'e'vcbvi tǵǵǵI tkǵ`ǵ Ges `vbvq miKvǵii GLwZqvi I `vq-`vqZǵ;chǵj vPbv KiǵZ cviǵeb|

**iǵóǵi fvgKv**

cwi KwǵZ ukŋvi mvǵ\_ ivóǵq `vqǵZǵi msthvM AvZ vbwǵo| GB cǵǵǵ½ meǵǵg Dǵj-LǵhvM" c`ǵǵc nj RbmaviǵYi ukŋv jvǵfi AvǵKvi mǵúǵK"ivóǵq KZǵe"i `ǵKwZ| fviZǵq msǵevǵbi tgǵj bmvZ Ges tgǵjǵj K AvǵKvi chǵq 45 Ges 46 bǵt AvǵUǵKǵj GK\_v ej v nǵǵǵQ| ivóǵq `vqZǵ;cvǵj Z nq tkǵ`ǵ, ivR" I `vbvq `ǵi, GB wǵkwǵi Askx`vviǵZǵ|

**tkǵ`ǵ miKvǵii fvgKv**

tkǵ`ǵ miKvǵii ukŋv wǵlqK `vq-`vqZǵ;mǵú`vǵbi Rb" iǵǵǵQ ukŋv gǵǵǵj q| ukŋvgǵǵ GB gǵǵǵj ǵqi cǵvb| gǵǵǵK mǵvnh" Kivi Rb" iǵǵǵQb GKrb mǵPe, GKrb AvZwi<sup>3</sup> mǵPe Ges ukŴǵysL"K hǵǵmǵPe, DcmǵPe I mnKvix mǵPe| gǵǵǵj ǵqi AvǵZvq cǵq 46wU `ǵqZǵkwmZ cǵZǵvb iǵǵǵQ| thǵ,tjv ukŋv gǵǵǵj ǵǵK mgǵq cwi Kǵbv I KgǵmǵP mǵMvb I ev`ǵvqǵb mǵvnh" Kǵi \_vǵK| gǵǵǵj q KZR. ukŋvi `vq-`vqZǵ; bmvZMZfvǵte Avgj v I ukŋvme`MǵYi thǵ\_ cǵǵǵmi gva`ǵg mǵúv`ǵbi K\_v wǵwǵbawǵŋv Kǵgkb wǵǵcǵǵU`Dǵj - L Kiv nǵǵǵQ| KvǵǵǵǵI Aek" cǵq mKj tǵǵǵI B Avgj vǵ`i cǵvrb" t`Lv hvq|

gǵǵǵj ǵqi cǵvb `vqZǵ; nj— (K) ukŋvǵǵǵǵI mǵhvM-mǵǵavi mgǵǵ, (L) `eAvǵbK I KwǵMix ukŋvi cǵvvi I DbwZ, (M) D"p ukŋvi gvǵbvǵǵb, (N) meǵKvi MǵelYvi Drmǵv I mǵúǵvviY, (O) meǵviZǵq cwi Iǵ`i gva`ǵg cǵǵǵK I gva`ǵgK ukŋvǵǵǵǵI ivR", tjvi cǵǵǵvi mgǵǵ, (P) wǵw`i wǵ`liY I Ab`vb" fviZǵq fvǵvi Dbǵb, (Q) ukŋv wǵlqK hvǵZǵq e`vcǵǵi Ab`vb" t`k I UNESCO-Gi mvǵ\_ thvMvǵhvM mvab Ges (R) ukŋv Kǵgkb vbǵqvmKiY I ukŋv cwi Kǵbv cǵǵǵb|

ukŋvi wǵwǵbawǵ K I `li mǵúǵK"ukŋv gǵǵǵj ǵǵK cǵvgk" cǵvǵbi Rb" thme cǵZǵvb iǵǵǵQ tm,tjvi gǵa" DǵjLǵhvM" KǵqKw nj – All India Council of Elementary Education, National Institute of Basic Education, All India Council of Secondary Education, University Grants Commission, All India Council of Technical Education, Central Advisory Board of Education (CABE), National Council of Educational Research and Training (NCERT) cǵwZ. mǵMvb|

**ivR` miKvtii `wqZ;**

mysieavibK A#\_uk`vi `wqZ; ivR` miKvtii | ivR` miKvtii GKUW ivR` uk`qv  
gšyvj q itqtQ, hvi c`vb nj GKRB gšy | ivR`i gE`gšy KZR. ubtqvMc0B  
uk`qvgsy Zui `vq`wqZ; Reve`xmvzi Rb` cvj`gtUj ubKU `vqx | ivR`i  
c0`ugK I gva`ugK uk`qv me`aK mel`q uk`qvgsy c0q me`gq qvgZv itqtQ |  
we`vj`q ciWZe` mel`q, ciV`vb mgqmP I cxWZ, uk`vtKi teZb I PvkZmewa,  
Qv`teZb BZ`w` mel`q ivR` miKvi B bmvZ uba`Y Kti `vtK | G Qvov bvi`uk`qv,  
eq`uk`qv, Kvi Mvi x I e`E uk`qv m`u`K`P ivR` miKvtii cE`q `wqZ; itqtQ |  
gva`ugK uk`qv Rb` itqtQ Avav-miKvix uk`qv tevW` c0`ugK I gva`ugK `ti i  
uk`qv cwi Pvj bvi t`q`T ivR` miKvi `vbxq `vq`E`xvmZ c0Z`vbmgt`ni  
mnhvMvzi Dci wbf`P Kti | c`qv`š`ti, D`P uk`qv t`q`T ivR` miKvi `vq-  
`wqZ; mekte`vj q I tK``xq miKvtii mvt` fvm Kti tbq | Ab`K`vq ejv hvq,  
we`vj q ch`q gj-Zt `vbxq miKvi I ivR` miKvtii Askx`vvi Z; Ges D`P uk`qv  
ch`q gj-Zt ivR` miKvi I tK``xq miKvtii Askx`vvi Z; iaZ; tctq AvmtQ |  
gšyvj`q KgrvE` cwi Pvj bvi Rb` GKRB m`P`tei tbZ`Z; GKUW m`Pevj q  
itqtQ | G Qvovl itqtQ Rb`uk`qv cwi Pvj`Ki `Bi | Gi kvLv mefvm tRjv ch`  
we`Z | Rb`uk`qv cwi Pvj`Ki `B`ti c`v`bi kvR n`Q uk`qv mef`b`e`q`T MpxZ  
bmvZ ev`v`qb Kiv | ersj vt`ki Rb`uk`qv cwi Pvj bvi gZB fvi`Zi Rb`uk`qv  
cwi Pvj`Ki `B`ti cwi Pvj K, Dc-cwi Pvj K, mnKvix cwi Pvj K, `z` BY`c`i,  
mgyvi fivRvi c`ch`vi KgrZ`P itqtQ | Zte e`e`vcbvi w`K w`q mef`b`e  
ivR`i g`a` w`Q`v w`b`z`v t`Lv hvq | w`P`T fvi`Zi cwi`get`zi gva`ugK uk`qv  
c0`vmbK Kv`vtgv Dc`vcb Kiv nj |

**`vbxq uk`qv KZE`q**

c0ZUW ivR` uk`qv gšyvj q c0`ugK I gva`ugK uk`qv ubq`šy Kitj I `vbxq  
KZE`q uk`qv c0`vmb e`vcb fivte AskM`Y Kti `vtK | tRjv ch`q c0`vmb`K  
w`K``Kiy Kti w`D`v`m`c`v`j`w Ges c`v`q`Z`K c0`ugK I gva`ugK uk`qv  
e`e`vcbvi `wqZ; t`qv n`q`q`Q | c0`ugK uk`qv`K meR`b`x I eva`Zvgj-K Kivi  
D`T`k` "District Approach" M`Y Kti tRjv uk`qv c0`vmb Kv`vtgv k`v`k`v`x  
Kiv n`q`q`Q | Zte Kvi K`z`v I w`t`j`em c0`qb, uk`qK ubtqvM I c0`q`Y, cix`qv  
I A`q`b I BZ`w` `iaZ`c`Y`K`v`h`ej`x ivR` miKvtii ubq`š`b`B itqtQ |

metk`I ejv hvq, uk`qv c0`vmb ivR` c0`vmb`bi GLWZq`ti n`j I me`vi Zxq  
cwi K`i`bvi m`v`th` e`E e`e`v, mekte`vj q g`Aj`x Kugkb Ges mef`b`e`me`vi Zxq  
cwi l`i`ga` w`q, m`e`c`wi Avv`R m`v`th`i me`bg`q cE`q uk`sev c`t`v`q`f`v`te  
tK``xq uk`qv gšyvj q n``q`c Kti b |

**w`P`T 2: fvi`Zi uk`qv c0`vmb Kv`vtgv**

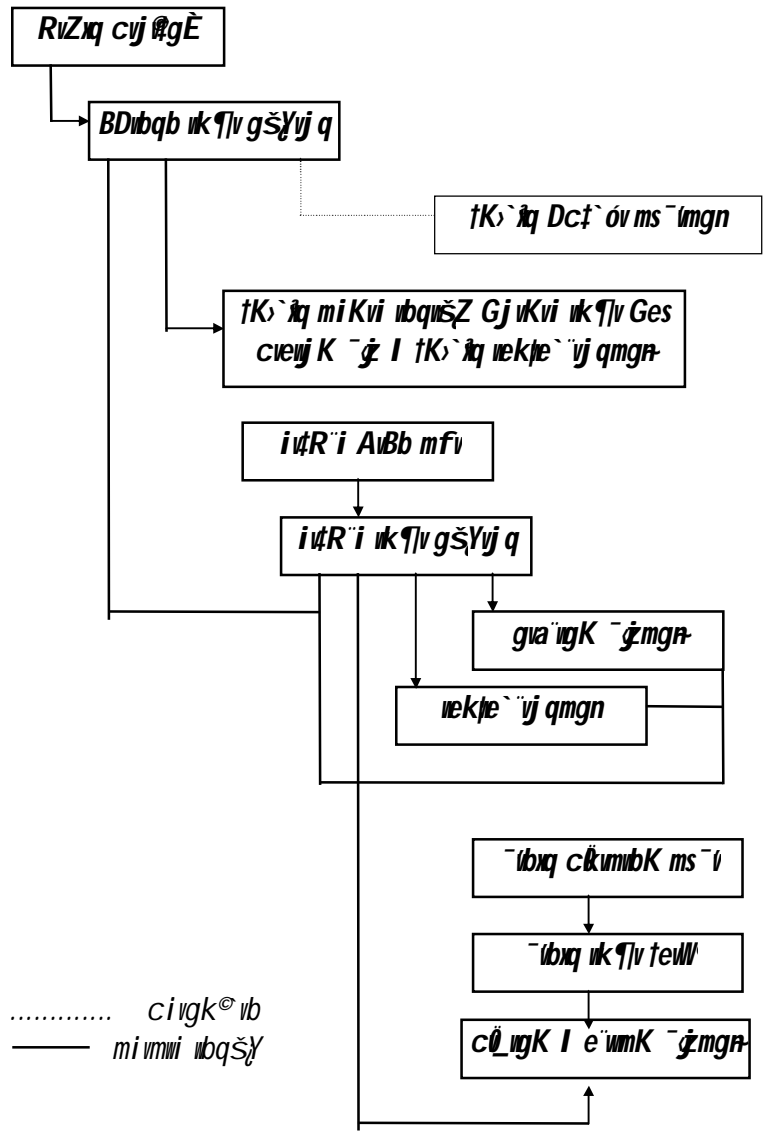



### civvEi gj`iqb - 3

#### A) eú ubePbx ckae

mivK DEi ibt`Rgj-K AqiuUtk eEivqZ Kiab | (D`vniY: Avcbvi ubePZ DEiU K ntj GtK (K) eEivqZ Kiab)

1. ukqlv Kugkb ibtqum KiYi `vqZj cvj b Kti tkvbuU?  
 K. tmUij AvWfvBRvi tevW<sup>o</sup>Ae GWzkkb  
 L. tk>`iq ukqlv gšyvj q  
 M. ivR` ukqlv gšyvj q  
 N. `vbxq ukqlv KZeql
  
2. tkvb `ti ukqlv cmiPvj bvi tqti ivR` miKvi I tk>`iq miKvi `vq-  
 `vqZj fvm Kti tbq?  
 K. cU`ugK ukqlv  
 L. gva`ugK ukqlv  
 M. D`P ukqlv  
 N. eEij-K ukqlv
  
3. ve`ij tqi ukqlKt`i teZb I PvKzmeia m`umKz bviZ ubafl Y Kti tk?  
 K. tk>`iq miKvi  
 L. ivR` miKvi  
 M. `vbxq KZeql  
 N. ve`ij q KZeql
  
4. ugDuvimcvij uU Ges cAvtqtZi `vqZj tkvbuU?  
 K. Kvi Kzvg I mtj evm cU`qb  
 L. ukqlK ibtqum I cUkqY  
 M. QvT teZb ubafl Y  
 N. cU`ugK I gva`ugK ukqlvi e`e`rcbv

#### Av) msifB DEi ckae

1. tk>`iq ukqlv gšyvj tqi cAvb `vqZj, tj vi Dtl Kiab |
2. ivR` ukqlv gšyvj tqi cAvb `vqZj, tj vi Dtl Kiab |



### mivK DEi

A) 1 | L, 2 | M, 3 | L, 4 | N |



### Povšgĵiqb

#### A) eŭ bePbx cĕæ

miWK DEi wĵ`Rgj-K AŕĵiUĵK eĖmqZ Kiab | (D`vniY: Avcbri bePZ DEiU K nĵ GĵK ⊗ eĖmqZ Kiab)

1. 1966 mĵĵ tKvb wĵĵv Kĵgkb MVb Kiv nq?
  - K. Zviv Pŭ KĵĵU
  - L. ivavKòY Kĵgkb
  - M. tKvvi x Kĵgkb
  - N. gŷmĵ qi Kĵgkb
  
2. wZb-fvlv mĵ Abĵvqx wŷ`x AĀĵĵ wĵĵYxq fvlv nĵe tKvbiU?
  - K. BŷĵiUR, wŷ`x I Ab` GKŭ AvajĵK fvlv
  - L. gvZfvlv, BŷĵiUR I wŷ`x
  - M. gvZfvlv, wŷ`x I GKŭ wĵĵY fvi Zxq fvlv
  - N. gvZfvlv, BŷĵiUR I GKŭ wĵĵY fvi Zxq fvlv
  
3. tKvb tkYx chŷiwĵĵĵK wbgæva`wĵK `ĵi i wĵĵv eĵj aiv nq?
  - K. 8g tkYxi ce`chŷi
  - L. 8g tkYx chŷi
  - M. 10g tkYxi ce`chŷi
  - N. 10g tkYx chŷi
  
4. Dbĵĵ wĵ`ĵĵ q `vcb Kiv nq tKvbiU KZR?
  - K. Bw` iv MvŪx b`vkbyj I ĵcb BDŭbFvmmŪ
  - L. tmŪĵĵ tevW`Ae tmĵKŪvix GWḖKkb
  - M. ivR` Kwvi Mmi wĵĵv tevW`
  - N. Dĵĵi i tKvbiUB bq
  
5. tKvbiU D`P wĵĵvi `vq-`wqZjenb Kĵi?
  - K. ivR` mi Kvi
  - L. tK`ĵq mi Kvi
  - M. wĵĵĵĵ `ĵĵ q
  - N. Dĵĵi i me,ĵĵ v

**Av) iPbrgj-K cka**

1. fviZi RvZxq ოქვიბოვ, ოქვი j ოქ I DfI k'vevj Dvj L Kiab|
2. fviZi ოქვი KvjtgvmZ ifc eYv Kiab|
3. fviZi ოქვი cka mb I e'e'vcbvi tvtI tK>iq miKvi, ivR' miKvi I vbxq KZetvi fvgKv eYv Kiab|



**mWK DEi**

A) 1| M, 2| K, 3| N, 4| L, 5| N|

## fıgKv

ŦŦY GKıq t`k,ıj i gta" kij sKv ukŦvi tŦŦI mtePP mvdj" ARŦ KiŦZ mŦlg  
 ntqtQ| 1948 mtj ˆvaxZv jvŦfi ci kij sKvq GKıU bZb MYZvıŦK I cMıZkıj  
 mgvR MVŦbi Rb" ŦbiŦi Zv ˆıkiY, ukŦvŦK meRbxkKiY I RbMŦYi Rb" ukŦvi  
 mgmŦhM mııKiYŦK cıvb jŦ" ŦmŦe ŦPıyZ Kiv nq| cıŦ t\_ŦK ŦPŦi eQi eqmı  
 tQŦj ŦgŦŦ"i Rb" ukŦv eva"Zıgj-K Kiv nq Ges ŦKŦvi MıŦUŦ ˆıı t\_ŦK Ŧektıe ˆıj q  
 ˆıı chŦı ukŦvŦK A%ZıvK Kiv nq| eZŦvŦb kij sKvi mŦŦi Zvi nvi cŦq 90 kZıvsk  
 Ges GZ`vÁŦj kij sKvB meŦŦg meRbxk cŦıgK ukŦvi jŦ" gvıv ARŦ KiŦZ mŦlg  
 ntqtQ| ukŦvi meŦŦi kij sKvi ıYMZ I cııı gvıYMZ mvdj" Dbqbkıj t`k,ıj i Rb"  
 ukŦYıq| eZŦvb BDİbŦU kij sKvi ukŦv e"e"vi ŦeŦki KŦqKıU ŦıK I ˆııktŦı Dci  
 AvŦj vKcvZ Kivi jŦŦ" ŦZbıU cvV Dc"ıcb Kiv ntqtQ|

cvV - 1 kij sKvi eZŦvb ukŦv e"e"vi  
 cUfıg Ges ukŦvi jŦ" I DŦıK"

cvV - 2 kij sKvi ukŦv KivıŦgv

cvV - 3 ukŦv cııııb I e"e"ıcbı



**cW 1**

**kij sKvi eZgub ukqlv e`e`vi cUfug Ges ukqlvi j ql` I Df`ik`**

**Df`ik`**

GB cW tkfI Avcub —

- ◆ kij sKvi eZgub ukqlv e`e`vi cUfug e`vL`v Ki tZ cvi teb;
- ◆ ukqlvt`ql`I kij sKvi eZgub iv`o`iq bniZ Dfj L Ki tZ cvi teb Ges
- ◆ kij sKvi ukqlvi mvavi Y j ql` I Df`ik` eY`v Ki tZ cvi teb/

tlvok kZvãtZ cW`ogv kw`i AvMgtbi ce`chSf kij sKvi ukqlv uQj tešx `k`bi Dci cãZw`Z Ges ukqlv e`e`v uQj tešx gw`i tKw`K| 1505 mvtj cZ`Riv me`g kij sKvq AvMgb Kti Ges kij sKvi ukqlv e`e`vq cwieZ`bi mPbv Kti| cZ`Riv Rbmvari Y tK tivgvb K`v`uj K atg`agf`Sni Z Kivi j t`ql` `q` vcb iia Kti| 1658 mvtj cZ`R kumtbi tkfI I j`vRt`i AvMgb NtU| Zviv ukqlv e`e`vq tKvbjc cwieZ` bv Gtb cZ`Rt`i Abvri Y Ki tZ `vtK| 1796 mvtj kij sKvi ubqšY Bstir`i nvtZ Avtm| Zviv ubgwe`t`ii `ql` Rbkw` `Zvi i j t`ql` Bstir`i gva`tgi `q` cwi Pj bv iia Kti| dj kãZ`Z 1869 mvtj kij sKvq wWcvU`gU Ae cveij K BYU`Kkb MWZ nq Ges axti axti ukqlv e`e`v Mto I vtZ `vtK|

1948 mvtj `vaxbZv j t`fi ci bZb Ges cwi ewZ` mgvR MVtbi j t`ql` ukqlv e`e`vi cW`Pb iia Kiv nq| ukqlvt`K A`eZubK Kiv nq Ges gvZfv`vtK ukqlvi gva`g wntmte Pj yKiv nq| HwZn`MZfvte cPuj Z mvavi Y avivi ukqlvi cvkvcuk weAvb I chny`MZ ukqlvi Dci `iaZ; Avtvc Kiv nq| Gi dtj ukqlv t`ql`I, wefkl Kti cj` AAtji ukqlv t`ql`I e`vcK cwieZ` mvaZ nq| ukqlvi j ql` Ges ukqlv ckvmb I e`e`vcbvi t`ql`I `iaZc`cwieZ`bi mPbv nq|

**iv`o`iq bniZ**

mKj bvmvi KtK ukqlv c`v`tbi `vqZi cvj`tb iv`o` A`xKvive`x| wK`v`i MvtU` t`K wekte`ij q chSf mKj `t`ii ukqlv A`eZubK Ges 14 eQi eqm chSf ukqlv eva`Zvgj-K| ukqlvi hveZiq e`q mi Kv t`i tK``iq Znvej t`K wbein Kiv nq| temki fivM `q`B mi Kvi KZR`ubqšZ| Zte temi Kvix `q` cwi Pj bvi t`ql`I mi Kvi Avc`E D`vcb bv Ktj I tKvbjc AvM`R mniqZv c`vb Kti bv| temi Kvix `q` `eZubK I A`eZubK `B a`tbi ntq `vtK| c`t`gv`u cãvZ Qv`I teZtbi Dci wbf` Kti Pj Ges tkfI v`u Avf`veK I c`t`cv`K i fivKv`Lx`i `v`tbi Dci wbf` Kti Pj | iv`o` `xN`tbi HwZn`evnx t`kxq ukqlv cãZ`v`b Pirivena `tj vtK AvM`R mniqZv c`vb Kti| Gme cãZ`v`b aglq Pirivena tKw` Ablyq` cwi Pvi Z I ubqšZ nq| tešx atg`P msN-mb`v`t`i c`K`qt`Yi Rb` cãZw`Z ntj I Gme cãZ`v`b eZgub cjad ukqlv``i KtqKw` wefkl t`ql`I ukqlv c`vb Kiv nq|





### ciVvEi gj`iqb- 1

#### A) eü ubePbx cÿæ

mivK DËi ubt`Rgj-K AqjiUtk eFvqZ Kiab | (D`vniY: Avcbvi ubePZ DËiU K ntj GtK **K** eFvqZ Kiab)

1. kÿj sKvq KZ eQi eqm chSukqiv eva`Zvgj-K?  
K. 11  
L. 14  
M. 15  
N. 16
2. `faxbZv jvtfi ci kÿj sKvi ukqiv e`e`vq tKvb aitbi cwieZB mvab Kiv nq?  
K. gvZfvivtk ukqivi gva`g intmte Pvj Kiy  
L. weAvb I chv`MZ ukqivi Dci `iaZ; AvtivcKiy  
M. ukqivtk A%ZvbKxKiy  
N. Dcti i me`uj
3. Pirivena Kx?  
K. miKvi ubqusZ teSx ukqiv cÿZôvb  
L. cjav ukqiv` i mvari Y ukqiv cÿZôvb  
M. teSx mbvut` i ukqiv cÿZôvb  
N. teSx ag`v` i
4. tKvbuU kÿj sKvi ukqivi Ab`Zg cÿvb j`q`?  
K. Drcv`bkxj , eFvj-K Ges Kivi Mui `bcY` I `qZv evx Kiv  
L. weAvb, chv` I D`vbevgj-K tqt`I `qZv evx Kiv  
M. D`P ukqivi tqt`I mKj bvmui tKi mgvb mshvM mvv Kiv  
N. ukqiv` i gta` h`MvcthvMx Avb, `qZv I `vofvzi weKvk mvab Kiv

#### Av) msuqB DËi cÿæ

1. ukqivtqt` kÿj sKvi cÿvb mvdj` Kx?
2. `faxbZvi ci kÿj sKvi ukqiv e`e`vq Kx Kx cwieZBbi mPbv nq?
3. kÿj sKvi ukqiv e`e`vi cUfug Dtv L Kiab |
4. Pirivena ej tZ Kx tevsvq?
5. ukqivtqt` kÿj sKvi ivôiq bmvZ Dtv L Kiab |



#### mivK DËi

A) 1| L, 2| N, 3| M, 4| K |



Dci b`v`l| GCE A Level cix`lvq KZKvh`nl qvi ci D`P uk`lvi Rb` GB mKj  
eekje`ij tq fuz`nl qv hvq|

e`v`Pj i tRbv`ij WWM` Rb` wZb eQti wZbU wel q Aa`qb Ki`Z nq| mdj Zvi mv`  
`jeQti i tKvm`k`l gv`vm`WWM`j vf Kiv hvq|

welUk g`Wj Aby`ti 1980 mtj k`j sKvi Dvg` eekje`ij q `rcb Kiv nq|

### tUK`bK`ij GU` tFv`Kkbyj uk`lv

AvUwU cij tUK`bK`ij Bb`v`JDU Ges tP`S`U R`bqi tUK`bK`ij B`Y`U`JDU  
B`A`bqvi s, Kgv`Ges wR`tm l · vdUm GB wZb ai`bi tKvm`c`ii Pij bv Kti |

m`v`U`d`t`KU tKvm`tj v `jeQti i Ges b`vkbyj w`l`c`gv tKvm`tj v `B` t`K wZb eQti i |

W`P` 1: k`j sKvi uk`lvi KW`g`MZ w`b`m

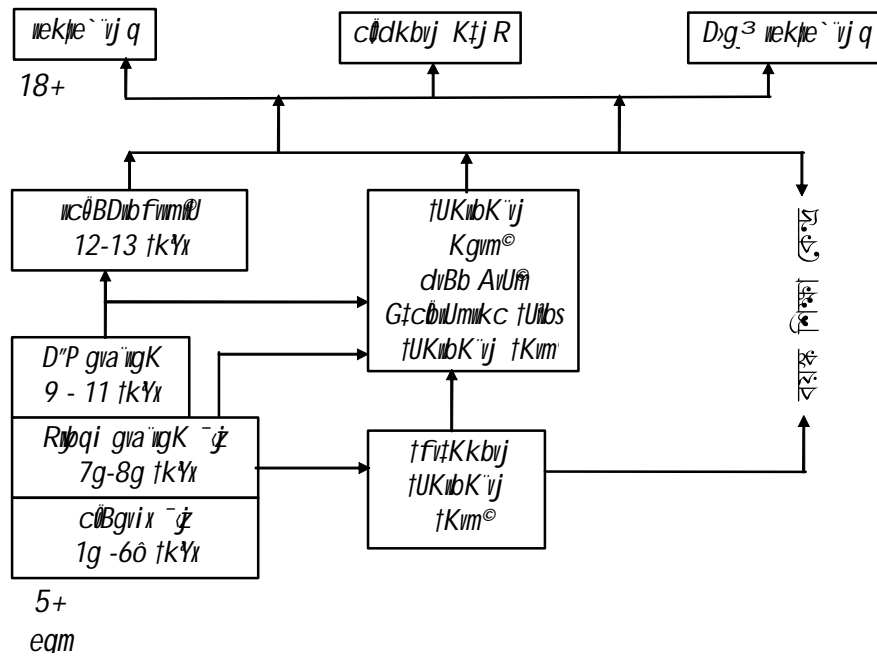

Drm: UNESCO



### ᄡᄢVvEi gj`vqb - 2

#### A) eū vbePbx cᄡæ

mᄡWK DĒi vᄡᄢ ᄡgj-K Aᄡᄢi vᄡᄢK eᄡvᄡqZ Kiab | (D`vniY: Avcbvi vbePZ DĒi vᄡ K ntj GᄡK (K) eᄡvᄡqZ Kiab)

1. kᄡj sKvi mᄡvavi Y vᄡᄡᄢvi e`vᄡB KZ eQi?
  - K. 11
  - L. 13
  - M. 14
  - N. 18
  
2. kᄡj sKvq GCE O Level ᄡi vᄡᄢᄢ KLb AbyᄡZ nq?
  - K. Aóg tkYxi tkᄡᄢ
  - L. `kg tkYxi tkᄡᄢ
  - M. GKv`k tkYxi tkᄡᄢ
  - N. ᄡᄡqv`k tkYxi tkᄡᄢ
  
3. kᄡj sKvi e`vᄡPj i tRbvᄡᄢij vᄡvᄡMᄡᄡKvᄡᄡ KZ eQᄡi i?
  - K. `ᄡ
  - L. vZb
  - M. Pvi
  - N. cᄡᄡ
  
4. kᄡj sKvi cᄡᄡᄡᄡK vᄡᄡᄢᄢ ᄡᄡi i e`vᄡB tKvb tkYx chᄡᄡ?
  - K. 8g
  - L. 7g
  - M. 6ᄡ
  - N. 5g

#### Av) msvᄡᄡB DĒi cᄡæ

1. mᄡvavi Y vᄡᄡᄢvi ᄡᄡᄡᄡᄡᄡ v tgqv`mn Dᄡᄡᄡᄡ Kiab |
2. tUKvᄡK`ij GWᄡKkb tKvᄡᄡᄡᄡ ᄡᄡᄡc Kx?



#### mᄡWK DĒi

A) 1 | L, 2 | M, 3 | L, 4 | M |

**cv 3**

**uk`vl c`kumb I e`e`vcbv**

**D`ik`**

GB cv tk`l Avcb —

- ◆ klj skvi uk`vli c`kumbK Kvvtgv e`vL`v Ki`Z cvi`teb;
- ◆ uk`vl gš`yij q Ges w`ri biy uk`vl w`fv`mi `vqZi I KZ` D`ij L Ki`Z cvi`teb Ges
- ◆ uk`vl c`kumb I e`e`vcbv Kvvtgv w`p`f`l Dc`vcb Ki`Z cvi`teb|

**tK``iq c`kumb I e`e`vcbv**

klj skvi ms`eavb Ablyvqx c`RvZt`šj me`gq vlgZvi Aw`Kvix t`c`m`f`WbU| gš`yij tqi w`bqš`Y Ges `vqZi i`q`q`Ob gš` Ges Zvi Aax`b i`q`q`O w`fv`M| gš`MY Zv`i w`b`f`n vlgZv t`c`q \_v`f`Kb t`c`m`f`Wb`Ui KvO t`\_t`K| uk`vl gš`yij tqi w`b`f`n c`avb n`f`Ob uk`vlgš`| Zv`K m`v`q`Zv`v`b`i Rb` i`q`q`Ob Dc`-gš` Ges c`R± gš`| uk`vlgš`i Aax`b uk`vl m`pe uk`v`v`v`Zi mdj ev`-`v`q`f`b`i `v`q`Zi` cvj b K`f`b| w`Zv`b gš`yij tqi w`fv`M Ges Ab`v`b` c`O`Z`v`b, hv uk`vl gš`yij tqi Aax`b, Zvi m`v`e`R KvR K`f`g` w`bqš`Y Ges Z`v`i`K K`f`i \_v`f`Kb| mi`Kv`f`i`i uk`v`v`v`Z ev`-`v`q`f`b`i Aw`dm Kg`R`Z`P`I Kg`P`v`i`x`MY m`pe`f`K m`v`q`Zv` w`t`q \_v`f`Kb| uk`vl gš`yij tq i`q`q`O P`v`i`Rb Av`Z`w`i`<sup>3</sup> m`pe| Zv`v` c`O`Z`f`K w`b`R w`b`R w`bqš`Y`v`ax`b gv`V ch`f`qi Kg`R`Z`P` Kg`P`v`i`x`f`i`i w`bqš`Y K`f`i \_v`f`Kb| mi`Kv`f`i`i b`v`v`Z m`g`z`ev`-`v`q`f`b`i Rb` f`k`u`f`K P`v`i`w` G`j`v`K`v`q` f`v`M K`v` n`q`q`O| c`O`Z`w` G`j`v`K`v`i `v`q`Zi; w`b`q`v`v`R`Z` G`K`R`b Av`Z`w`i`<sup>3</sup> m`pe Zv`i ÷`vd w`bqš`Y Ges Zv`i Kg` G`j`v`K`v`i c`w`i`k`O K`f`i \_v`f`Kb| Av`Z`w`i`<sup>3</sup> m`pe`f`K m`v`q`Zv` `v`b`i Rb` i`q`q`O t`W`c`w`l g`n`v`c`w`i` P`v`j` K (uk`vl), c`w`i` P`v`j` K (uk`vl), c`avb w`m`v`e` i`v`K, W`v`B`f`i`±i Ae`-`f` I`q`v`K`f`i, w`m`b`q`i m`n`K`v`i`x` m`pe, m`n`K`v`i`x` m`pe, c`avb uk`vl Kg`R`Z`P` Ges w`m`v`e` i`v`K| G` Q`v`ov Ab` `w` w`fv`M, c`ix`v`l w`fv`M Ges uk`vl c`K`v`k`b`v` w`fv`f`mi `v`q`Zi; i`q`q`Ob `B`R`b K`v`g`k`b`v`i`|

uk`vl gš`yij tqi `v`q`Zi` g`f`a` i`q`q`O w`v`i` s`-`Z`w`i, Av`m`e`v`e`c`f`i, uk`vl Dc`K`i`Y, cv`w`e`B Ges uk`vl`\_`f`i`i Rb` g`a`v`y` L`v`e`f`i`i e`e`-`v` K`v`| uk`vl gš`yij tqi m`pe c`R± w`v`b` ÷`v`f`i`i Aax`b `f`z` m`v`v`i`K`Z` G` m`g`-`f`K`v`f`R`i `v`q`Zi; cvj b K`f`i \_v`f`Kb|

G` Q`v`ov c`w`e`j`K` m`w`f`f`i` K`v`g`k`f`b`i Aax`b G`W`z`K`k`b` m`w`f`f`i` K`v`g`w`U` b`v`f`g` G`K`w`U` `v`ax`b m`s`-`v` uk`v`K` w`b`q`v`M, c`f`-`v`b`v`Z, c`lyt` w`b`q`v`M Ges uk`v`K, Kg`R`Z`P`I Kg`P`v`i`x`f`i`i k`;`L`j`v` I` m`f`h`v`M m`g`e`v`i` e`e`-`v` K`f`i \_v`f`Kb|

**Av`A`ij K c`kumb I e`e`vcbv**

uk`vli K`v`h`f`ig` ev`-`v`q`f`b`i c`K`Z.`v`q`Zi; w`v`f`b`v`v`i`w`ri biy uk`vl w`fv`f`mi | t`\_t`ki 24w`U c`kumbK w`v`v`-`f`-G` 24w`U w`v`c`v`U`g`y`U i`q`q`O| c`O`Z`w` w`ri w`ri biy w`v`c`v`U`g`y`U G`K`R`b w`ri w`ri biy W`v`B`f`i`±i Ae` G`W`z`K`k`b` O`v`i`v` c`w`i` P`v`ij` Z` n`q`| W`v`B`f`i`±i`K` m`v`q`Zv` w`t`q \_v`f`Kb` c`avb uk`vl Kg`R`Z`P`, uk`vl Kg`R`Z`P`, G`K`R`b w`m`v`e` i`v`K, `f`z` m`p`v`v`š`f` K`v`f`R`i` Rb`

ḡ Ae GWKKb

GKRb ubelx cii Pij K Ges GKRb mzi fivBRvi whub mivK<sup>0</sup> GWKKb Awdmvi bvtg  
ciiiPZ| Zj bvgj-Kfvte AfbK eo ckvmbK Ww÷± thLvfb ḡj i msL'v Ges ukḡv\_ḡ  
msL'v AfbK tenk, tm mg'í Gj vKvi cãvb GWKKb AwdmviḡK GKiu Awdm Ges  
GKiu mve Awdm mniqZv w'ḡq \_vḡK|

wiurI bij GWKKb Awdḡmi KivḡK cãvbZ 5iu fivM fivM Kiv nḡqḡQ| G,tjv nj -  
ukḡv ckvmb, ukḡv Dbqb, mivavi Y e'e'vcbv, A\_ḡqb Ges ḡj cãZov ubgḡYi KivR|  
wiurI bij WvBḡi±i Ae GWKKb (RDE) ukḡv Dbqb wefvḡMi wefvMiq cãvḡbi `vqZj  
cij b Kḡi \_vḡKb Ges Ab" wefvM,ij i mḡze'e'vcbvi e'e'v Kḡi \_vḡKb| th mKj  
wiurI b-G mve Awdm iḡqḡQ tm mKj wiurI ḡbl mve Awdm Gj vKvmn mḡze'e'vcbvi  
`vqZj RDE enb Kḡi \_vḡK| mve Awdḡmi `vqZj \_vḡKb cãvb ukḡv Awdmvi Ges  
Zvi Aaxḡb Ab'vb" mniqZvKvix ÷vd| mve Awdḡmi KivRKg<sup>0</sup> Gj vKvi mivavi Y  
e'e'vcbv, A\_ḡqb Ges ḡj i Kgḡvḡi ḡḡa" mniqZ \_vḡK|

cãZiu Ww÷± Avevi KḡqKiu mivKḡU wef<sup>3</sup>| Mḡo cãZiu mivKḡU 30 t\_ḡK 40iu ḡj  
AvḡQ| cãZiu mivKḡ-Gi `vqZj GK GKRb ukḡv KgḡZ<sup>0</sup> iḡqḡQb| Zvi cãvb KivR  
mivKḡU i mg'í ḡ,tjv mzi fivBR Kiv| wZub ḡj Ges wiurI bij WvcvUḡyU Ae  
GWKKb-Gi ḡḡa" thvMḡvM iḡv Kḡi \_vḡKb| Zivovov iḡqḡQ wḡkl mivKḡ GWKKb  
Awdmvi whub wewfbawelq thgb wEÁvb, Kul, emYR", Min<sup>0</sup> wEÁvb, tḡSḡ wEÁvb, Kj v,  
j ij Z Kj v wElqv i mzi wfkḡbi `vqZj;wbḡqvRZ|



**WPI 2: ksj sKvi ikqiv e`icbvi Kwiugv**

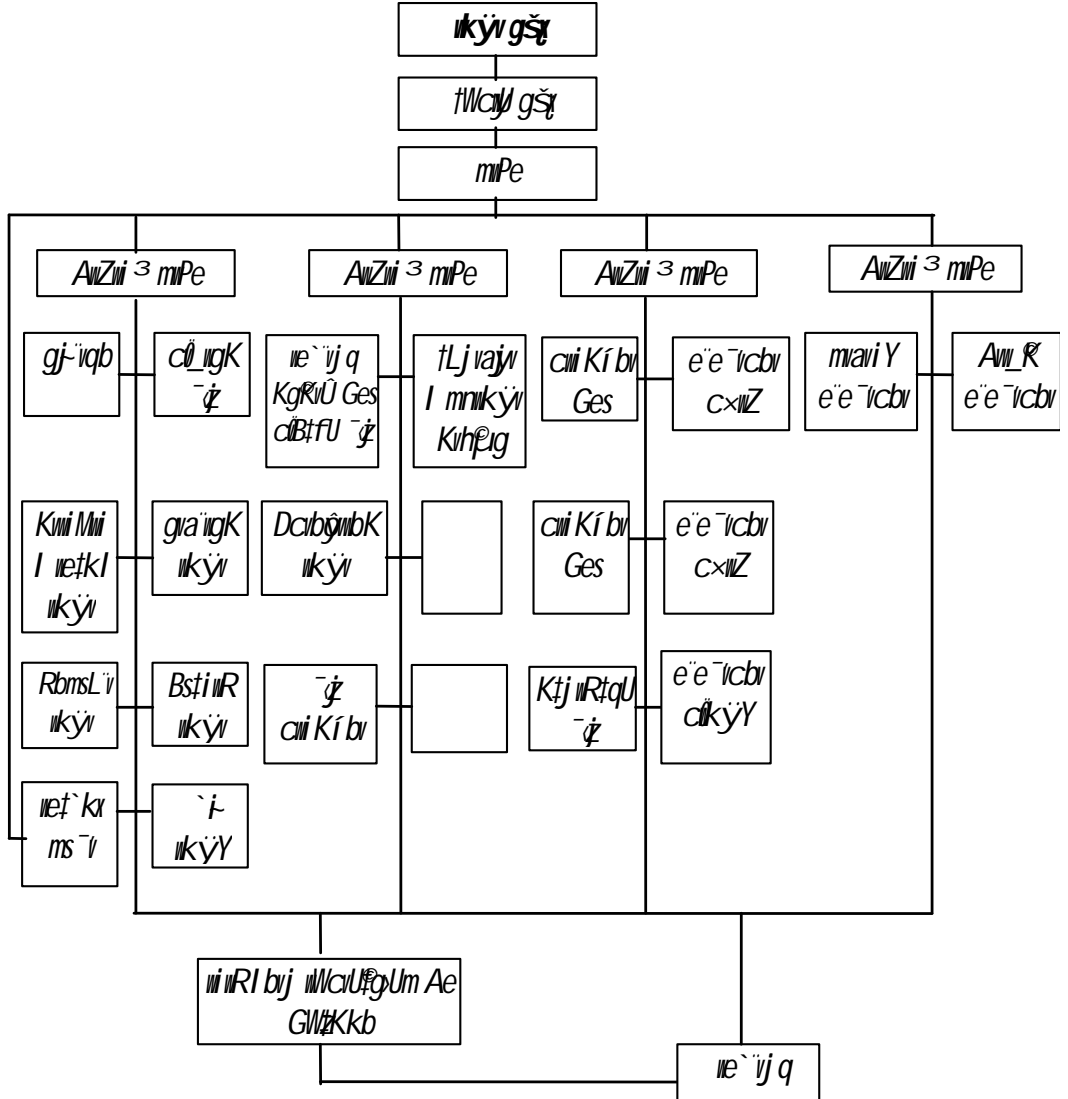



### ცვლელი გვთხოვს - 3

#### A) ეუ ბეზბხ ცხე

მუშა DEი ბტ რგ-კ აქი მუშა ეწვივთ კიბ | (D`vniY: Avcbvi ბეზბხ DEიუ K ntj GtK (K) ეწვივთ კიბ)

1. ჩქ სკვი უკწვ გსჯვთ ჟი ბეზბხ ცხე ბტ?

- K. უკწვ გსჯ
- L. Dc-გსჯ
- M. ცხრ± გსჯ
- N. უკწვ მიპე

2. AvAj K Gj vKvi `vqZ; tK cvj b Ktib?

- K. ცხი Pvj K (უკწვ)
- L. tWcuj gncvi Pvj K (უკწვ)
- M. AvZvi 3 მიპე
- N. Dcgჯ

3. უკწვ ბტყტმი ე`ე`v tK Ktib?

- K. მიური ბჯ უკწვ ეწვი
- L. ცხმობK wv÷±
- M. მუშა Kuj
- N. გვზკკბ მწმ Kuj

4. უკწვ tქt tKvბუი Avl Zv ქzZi?

- K. მიური ბ
- L. wv÷±
- M. მუშა
- N. BDubqb

#### Av) მსწვ DEი ცხე

1. მიკვთი ბვზ მწმ ეწვი ბეზბხ რბ` Kx Kx ე`ე`v MhY Kiv ntqtQ?

2. უკწვ გსჯვთ ჟი ცხე ბტ`vqZ; Kx?

3. მიური ბჯ გვზკკბ ანტმი კვრ, tj v Kx? Kxvte m`ubakiv nq?

4. მუშა უკწვ KგZPKx Kx Kvr Kti `vKb?



#### მუშა DEი

A) 1| K, 2| M, 3| N, 4| M|



### Povšigj`iqb

#### A) eü ubePbx ckae

mWK DEi ubt` Rgj-K Aqi uK eFvqZ Kiab | (D`vniY: Avcbvi ubePZ DEi uK ntj GtK K) eFvqZ Kiab)

1. Kij sKv uk qvi tKvb tqt mekaK AMMuz ARB Kti tQ?
  - K. uk qv e`e`vcbv
  - L. gva`igK uk qv
  - M. mvi Zi ARB
  - N. D`P uk qv
2. Kij sKvi uk qv tKvb `li chS/A%eZubK?
  - K. cü`igK
  - L. ubgagva`igK
  - M. D`P gva`igK
  - N. wekte`ij q
3. GCE A level ci xqv KLB AbyoZ nq?
  - K. Ttqv`k tkYxi tk tI
  - L. GKv`k tkYxi tk tI
  - M. `kg tkYxi tk tI
  - N. Aog tkYxi tk tI
4. Kij sKvq uk qv bMzi mdj ev`evqtbi `vqZi Kvi Dci AwZ?
  - K. uk qv gšx
  - L. uk qv Dcgšx
  - M. uk qv mPe
  - N. vi RI bij WvBti±i Ae GWzKkb
5. tKv u GWzKkb mwfñ Kugui Ki R bq?
  - K. uk qK, KgRZPI KgPvix`i k;Lj v I mshvM mpeavi e`e`v Kiv
  - L. cv`eB cü`qb I uk t qvcKiY `Zvi KiY
  - M. uk qKt`i ct`vbuz cü`vb
  - N. uk qK ubtqvM

#### Av) iPbvj-K ckae

1. Kij sKvi uk qv tqt i vóiq bMz Ges uk qvi j qI I Dti k` eYv Ki ab |
2. Kij sKvi uk qvi KvVtgvMZ web`vm uPImn eYv Ki ab |
3. uk qv gšxij tqi Mvb KvVtgv Ges Gi `vqZi I KZ@` Dti K Ki ab |
4. uk qv ckvmb I e`e`vcbvi tqt vi RI b, Wv÷± Ges mWKui fvgKv Dti K Ki ab |



#### mWK DEi

A) 1 | M, 2 | N, 3 | K, 4 | M, 5 | L |

# Bsj`vU'i ukvve`e`v

## figKv

c0q`B kZvax ati euk mvgR" miviv cu\_exi weifbæAAj I t`kRto we`Z.uQj | GB wekvj mvgR" kvmtbi Rb" weUti c0qvRb nq ctouQj c0kvmbK tgav, Kkjx Avb I DEg , Yvej xmubæecj mSL`K e`w`i | Gme e`w`i i w`tqB weUub mkyj tmeK (civil service) brtg weivU GK c0kvmb K`wvi Mto tZvtj thLvtb cveij K`dz ukvvc0B AwfRvZ Ntii mstbi vB thvM`vtbi teuk mshvM tcZ | u0Zxq gnvhj\* weUub Rqx ntj I A`%wZK I kw`gEvi w`K t`tK wech`I I aysmc0B nq | mvgR`i Dcubtek , tj vtZ ivR%wZK mPZbZv ewxi mvt\_ mvt\_ `vaxbZvi `vexl `gfi nq DVtZ `vtK | dtj GtK GtK etUb Gme Dcubteki `vaxbZv tgtb wbtZ eva" nq | euk mvgR`I mgk tft`/2 ctol wek' ivRbvzi tqtI etUb tbZZi nviq | uKs` A`g` gbrfve I AwfRvZ`eva euk`i tbZtZi `upv RvMiaK ivtL | Ggb cwi`wZtZB Zrkvjxb euk c0vbgšx wvmti Bjx tNvI Yv Ktib 00t`tki RbmvariYi ukvvi Dci t`tki fvel`Z wbfP Kti00 | GQvov ukvvi c0vbgP melqK Bt`hvti (1944 Lpvtai ukvvi AvBb c0vtbi cteP Avil tNvI Yv Kiv nq, 00mteEg Ziæ mgvRB Rvzi tk0Zg m`u`00 | wK G mgq t`tKB weUub ukvvcv`b, A`%wZK w`Zve`v I c0vP wekvtki ct\_ `æZ GwMtg thtZ mP0 nq | nvi vtr tbZZi I Hwzn` c0vævti c0vvcuk mgx I ukvvcv` t`k wmvte c0Zw0Z nqvi HKvšK evmbvB weMZ KtqK `kK ati weUubi ukvvi tPZbv I ukvvi e`e`vi c0wZ. I MwZaviv wbaftYi , iæZc`%bqvG wmvte cwi MvYZ nq AvmtQ |

GB BDibU wZbuU cW Dc`vcb Kiv nqtQ | cW , tj vtZ Bsj`vU'i c0\_wgK I gva`wgK ukvvi mgveKiv, eZ0vb ukvvi Kvvtgv Ges c0kvmb I e`e`vcbv m`utK` Avtj vPbv Kiv nqtQ |

- civ - 1 c0\_wgK I gva`wgK ukvvi mgveKiv
- civ - 2 ukvvi eZ0vb Kvvtgv
- civ - 3 ukvvi c0kvmb I e`e`vcbv

**cW 1**

**cŰ\_ugK I gva`ugK ukŷŷvi µgmeKivk**

**Dŷik`**

GB cW tkŷI AvciB —

- ◆ Bsj itŰi cŰ\_ugK I gva`ugK ukŷŷvi µgmeKivk Dtj - L KiŷZ cviŷeb;
- ◆ gvaugK ukŷŷvi m=úŷK®ewfbaeKugui mi gzwik avivevniK fviŷe Dtj - L KiŷZ cviŷeb Ges
- ◆ 1944 mŷbi ukŷŷvi AvBŷbi iæZi e`vL`v KiŷZ cviŷeb|

Aóv`k kZvāx chŷI mgvR `elg`B Bsj itŰi ukŷŷvi e`e`itK ubqŷŷy KŷiŷQ| ukŷŷvi uQj  
 `ŷ ŷŷi wef³| AwfRvZ mgvŷRi Rb` uQj A· tdiW`I K`igmeR mekte`ij q Ges  
 j`vub MŷK fvlv I mvinŷZ`i cŷvevaxb ŰŰMŷgvi ŷŷŷ| weEevbŷ`i itŷb A`ev e`w³  
 gvij Kivbq GBme ŷŷ Mŷo Iŷv| Kvj µŷg Gŷ`i gŷa`B tKivb tKivb D`P gvŷbi  
 AvevniK me`ij q ŰŰcvevŷ K ŷŷŷ inŷmŷe cwi wPZ nq Ges m=ú`k vij ŷŷ`i cŰZŷv nŷq  
 cŷo| `wi`ŷ`i Rb` uQj ŰŷWg& ŷŷŷ, ŰKgb tW ŷŷŷ BZ`wi e`w³MZ e`emvŷgK  
 cŰZŷv, ukQyukŷi -ukŷŷvi cŰZŷv Ges PivP`cwi Pviŷ Z A%eZivbK P`vni uU me`ij q|  
 mviŷiŷi ukŷŷvi uQj ubgæchŷŷqi Gij tgvŷvix ŷŷŷ i gŷa` mŷgve×| KvŷRB mviŷ`ŷk  
 bvbv aiŷbi thme ukŷŷvi e`e`v cŷvŷ Z uQj tm,ŷŷvi gŷa` tKivb mgŷŷq ev mvgŷm` uQj  
 bv| ukŷŷviŷŷŷ iŷŷŷ tKivb mŷgwiMŷK fvgKv uQj bv Ges tKivb RvZix ukŷŷvi e`e`v I Mŷo  
 Iŷvub|

ukŷŷviŷŷŷ iŷŷŷ c`vcŷ NŷU 1832 mŷbi ukŷŷvi Rb` evniŷ ivŷŷq eivŷi cŰZŷbi ga`  
 w`ŷq| Gici 1839 mŷbi cŰZŷv nq cvj ŷŷŷ gŷbvbvZ ukŷŷvi mŷµvŷŷi Kugui Ges  
 1870 mŷbi cvj ŷŷŷU civk nq cŰ\_ugK ukŷŷvi AvBb| GB AvBŷbi dtj ukŷŷ`cŰ\_ugK  
 ukŷŷvi mKj `vŷZB miKvŷi nŷŷZ Gŷvbn, PivP`Ges Ab`vb` t`Qvŷmex msMVŷbi  
 ŷŷ,ŷŷv Zvŷ`i cwi Piv bŷŷZB iBj Ges miKvix mvinv`I tŷŷZ `vKj | ukŷŷ`µgeaŷvb  
 cŰqRb tgvŷvbi Rb` ivŷŷq Dt`itM cŰ\_ugK ŷŷ cŰZŷvi e`e`v nj | GBRb` mŷŷ  
 nj mgMŷŷ`ke`vcx Űŷŷ tevWŷŷ| 1891 mŷbi cŰ\_ugK ukŷŷvi A%eZivbK I eva`Zivj-K  
 Kiv nj | 1894 mŷbi eŷBm Kugkb iagvŷ cŰ\_ugK ukŷŷvi `vŷZi ŷŷ tevŷWŷP nŷŷZ  
 Ges gva`ugK, Kvni Mvi ukŷŷvi I ukŷŷK ukŷŷŷi `vŷZi ŷŷEŷvniZ cŰZŷvbi nŷŷZ  
 t`qvi mŷvniK Kŷi | GB Kugkb RvZix wfiEŷZ ukŷŷvi cŷvmbŷK mŷvniZ Kivi Dtŷŷk`  
 ukŷŷvŷŷi c` Ges gŷŷi mŷvqK Űŷukŷŷvi cwi I Űŷ MVŷbi I mŷvniK Kŷi |

ukŷŷvŷŷi c` mŷŷ Kŷi ukŷŷŷK cŰ`ŷŷŷvŷe ivRbniZi gŷa` wŷŷq Avmvi weiŷŷ× ZLbI  
 iŷŷŷŷŷ AwfŷZ hŷ\_ŷ kwi³kijx uQj | ZvB gŷŷŷi mŷŷ nj bv| ukŷŷ`ŷŷ tevW`Zŷŷ  
 w`ŷq `vbxq ŷŷEŷvniZ cŰZŷvbi ukŷŷvi Kugui LEA (ŷŷvKij GWŷKvbiŷ A`wi uU)-  
 Gi nŷŷZ cŰ\_ugK, gva`ugK, ubgæKvni Mvi cŷvŷ. meiKg ukŷŷvi `vŷZi t`Iqv nj |  
 gva`ugK ukŷŷviŷŷŷ miKvix Dt`itMi mPbv nj 1902 mŷbi AvBŷbi ga` w`ŷq| Gi  
 dtj gva`weE I ubgæga`weE tkŷŷ DcKZ.nj | 1917 mŷbi Avi GK uU ukŷŷvi AvBŷbi

(ndmvi AvBb) cՕ՛ԼԵ Kiv nj th, thvM՛ZvmԻubemKtj i KvtQB gva՛ւղK ւկՊ՛ւ Օ՛ւ  
DbԻ՞ ը՛ւկԷ| bvmԻx ւկՊ՛ւԷ DrmvinZ Kiv nԷ| bvmԻxi Է՛ի ւկՊ՛ւKvj nԷ  
cՕ՛ւղK-gva՛ւղK-Kւ՛Ubjtqkb (continuation), GB ւZb փօք GkmԻ MՕ\_Z| Gici  
gva՛ւղK ւկՊ՛ւԷ ivՕ՛ղ AvbԻԷ՛՛ meRbxb Kivi ՝vexi Է՛ի 1926 մԷ 00n՛ւ՛W  
Kւղւ՛U՛՛ mgzvii k Kitj b thb mg՛Լւկii ՝KԻkvi RxebԷK ւԷ՛՛յ յ՛գի A՛՛fԷ Kiv nq,  
A\_Ի cԻkiv՛՛՛ի gva՛ւղK ւկՊ՛ւԷ mKtj i KvtQ DbԻ՞ Kivi cՕ՛ԼԵ Kiv nq| Avi  
Է՛ի ը՛ւկՊ՛ւ-ւbixՊ՛ւ Է՛ի 1938 մԷ 00Է՛ւY Kւղւ՛U՛՛՛ mgzvii Է՛ի QvԻ՛՛՛ Է՛ի cՕ՛YZv I mԻԷb  
AbԻyqx ւZb iKԻցի gva՛ւղK ւկՊ՛ւ Է՛ի Kivi cՕ՛ԼԵ Է՛ի Լq՛ nq: (K) hԻ՛՛ i ւեցZ  
Ges Է՛ի ւկՊ՛ւ Է՛ի cՕ՛YZv AvԷQ ZԻ՛՛ i Rb՛ ը՛ւկԷ ZԷgԻ-K ւկՊ՛ււղ Aej Է՛ի KԻ  
MՕvi փօք, (L) hԻ՛՛ i Kvi Mvi I hԻ՛՛՛՛ Է՛ի Է՛ի AvԷQ ZԻ՛՛ i Rb՛ ը՛ւկԷ  
ZԻ՛՛ Է՛ի Է՛ի ը՛ւկՊ՛ւ Է՛ի mg՛՛՛ յ՛UԻbK՛՛յ ը՛ւկՊ՛ւ Է՛ի Ges (M) hԻ՛՛ i Է՛ի ւկՊ՛ւ  
MՕԻԻ Է՛ի cՕ՛YZv AvԷQ ZԻ՛՛ i Rb՛ ը՛ւկԷ AԷ՛ի KZ. Է՛ի ZԻ՛՛ Է՛ի gWԻb ը՛ւկՊ՛ւ  
ւկՊ՛ւ Է՛ի Է՛ի mԻvԻY Է՛ի djvdj Ges Ab՛՛b՛ gb՛՛ Է՛ի cՕ՛YZv Է՛ի Aej Է՛ի KԻ  
QvԻ՛՛՛ i Է՛ի Է՛ի M KԻ ւZb aԻԷ Է՛ի յ՛՛ յ՛՛ Է՛ի Է՛ի Kiv nԷ|

GB ւի՛Է՛Է Dci ւԻ՛Է KԻ 1941 մԷ 00mvi biDW Kւղւ՛U՛՛ ւԻ՛-aviv ւկՊ՛ււղ I  
Է՛ի Է՛ի mԻԷ՛ի Է՛ի KԻ Ges 1942-44 մԷ 00g՛vKԻbqvi Kւղւ՛U՛՛ ւկՊ՛ւ  
ւկՊ՛ւԷ ւԷ՛ի յ՛՛ Է՛ի KԻ | BԻZvgԻ՛ MYZԻ՛՛ AvԷ՛՛ յ՛՛ Է՛ի Է՛ի Է՛ի  
aԻԷ Է՛ի յ՛՛ Ges Է՛ի K փօք յ՛՛ Է՛ի mԻԷ՛ի Է՛ի Է՛ի Է՛ի Է՛ի  
mԻԷ՛ի Է՛ի Է՛ի Է՛ի (1942-44) Ggb GK Է՛ի Է՛ի Է՛ի KԻ Է՛ի KԻ  
Է՛ի Է՛ի KԻ Giv me՛՛ Է՛ի RvZԻq ւկՊ՛ւ Է՛ի Է՛ի Ask nԷZ Է՛ի |

Gme ւի՛Է՛Է՛ dj kՕZB nj 1944 մԷ Է՛ի Է՛ի AvBb hvi mԻvԻԻ՛ Bsj ՝՛՛U me՛՛g  
GԻU me՛՛ Է՛ի RvZԻq ւկՊ՛ւ Է՛ի Է՛ի Է՛ի nj |

**ւկՊ՛ւ AvBb – 1944**

1944 մԷ Է՛ի Է՛ի AvBb BւZԻvԻ՛ evUj vi AvBb Է՛ի I Է՛ի PZ| GB AvBb Bsj ՝՛՛U  
mւղւ՛MԻ ւկՊ՛ւ Է՛ի Է՛ի Է՛ի Ges mԻԷ՛ի Է՛ի Է՛ի GԻԷQ| G Rb՛ GB AvBԻԷ  
՛ի Է՛ի ZԻ՛՛ aivi Rb՛ g՛՛ Kiv nq – “The Education Act of 1944  
constitutes the most important single progressive step ever taken in  
Educational history.” GB AvBb ւկՊ՛ւ Է՛ի Է՛ի Է՛ի Է՛ի Է՛ի Է՛ի I mԻԷ՛ի Է՛ի  
KԻ th me ms՛՛ Է՛ի Է՛ի Է՛ի MՕY KԻ Zv ւQj ւbցիԷ:

**(K) ւկՊ՛ւգ՛՛ ՝՛ Bi ՝՛Էb**

cԻկւմԷK Է՛ի Է՛ի GB me՛՛g Bsj ՝՛՛U ւկՊ՛ւգ՛՛ ՝՛ Bi ՝՛Էb KԻ Է՛ի Է՛ի ւbգ՛՛ I  
ւb՛՛ Է՛ի Է՛ի Kiv nq| g՛՛ԷK mԻvԻԻ՛ Kivi Rb՛ ՝՛U DԷ՛՛ օ՛ն Kւղւ՛U M՛՛Z nq|  
ւկՊ՛ւ Է՛ի Է՛ի Է՛ի Է՛ի g՛՛՛ յ՛՛ K mg՛M՛ ւկՊ՛ւ Է՛ի Է՛ի Z՛՛ Է՛ի K I ZԷԻԷԻԷ՛՛ ՝՛ ւիզԻ  
Է՛ի յ՛՛ nq|

**(L) `vbnq vkŷŷv KZ@tŷŷi `wqŷZŷi m`u`hviY**

wekŷe`ij q vkŷŷvi `wqŷZŷi b`v`l nq University Grants Commission (UGC)-Gi Dci | Avi c`l`wK, gva`wK, further education Ges b`v`v ai`tbi tUKubK`ij vkŷŷvi `wqŷZŷi t`l qv nq LEA, tŷŷvK | G Qvov bvmŷŷx `ŷ, t`ukvj `ŷ, hŷKj`vY e`e`v cŷŷŷi cwi K`i b`v `Zwi Ges e`e`vcbri `wqŷZŷi t`l qv nq LEA-tK |

**(M) vkŷŷvi wZbU mŷw`ŷ `ŷi i cwi K`i b`v**

vkŷŷvK Elementary | Continuing education b`v`g ceZb wefivR`tbi cwi e`Z c`l`wK, gva`wK | further education b`v`g wZbU mŷw`ŷ `ŷi web`v`tmi cwi K`i b`v Kiv nq | t`ŷki `ŷ, tŷŷvK `ŷŷŷŷ f`vM Kiv nq- (1) LEA KZŷ. c`Zw`Z | cwi P`vŷ Z KvDwU `ŷ Ges (2) P`P`I Ab`v` c`Z`v`b KZŷ. c`Zw`Z | cwi P`vŷ Z f`j`v`vix `ŷ | f`j`v`vix `ŷ, tŷŷvK Avevi wZb t`k`ŷ`Z f`vM Kiv nq, h`v- m`v`v`c`b `ŷ (aided school), we`k`l P`ŷ m`u`b`e`ŷ (special agreement school) Ges w`b`q`ŷ`Z `ŷ (controlled school) | Df`q t`k`ŷ`xi we`ij q`ŷ`Kb `^`^`ŷ`ŷ; | `e`w`o` e`R`v`q t`i`ŷ`L GKB KvW`v`g`v`i g`ŷa` Avb`v` nq |

**(N) vkŷŷvK eva`Zv`g`-K | A`%Z`v`b`K`i`K`i`Y**

c`w` t`ŷ`K 15 ermi ch`ŷ`A`ŷ m`u`ŷ`c`l`wK `ŷi Ges gva`wK `ŷi i 4 eQi ch`ŷ` vkŷŷvi meR`b`x`b, A`%Z`v`b`K | eva`Zv`g`-K Kiv nq | (1972-73 t`ŷ`K GB eqm`m`v`g`v`ŷ`K 16 eQi D`b`ŷ` Kiv n`ŷ`ŷ`Q)

w`Z`x`q wek`ŷ`ŷ`v`E`i Kv`ŷ`j 1944 m`v`ŷ`j i vkŷŷv AvBb ev`b`v`q`b Kiv nq | GB AvBb Kv`h`ŷ`i Kivi c`ŷ`e`B`ŷ`j`v`ŷ`i Rb`m`v`v`i`ŷ`Yi Av`k`ŷ`v` w`Q`j Zv`ŷ`i `ŷ`x`b`Z`v` ŷ`ŷ`e`n`ŷ`e` | w`K`ŷ` `x`N` w`ŷ`bi Av`ŷ`A`Z`v`q t`L`v` hv`q 1944 m`v`ŷ`j i vkŷŷv AvBb B`ŷ`j`v`ŷ`i vkŷŷv`q M`v`Z`k`x`j Z`v` | `e`w`ŷ` G`ŷ`b`ŷ`Q |



### ciVvEi gj`iqb - 1

#### A) eũ bePbx cŁæ

mWVK DĒi ũbᄃ Rgj-K AᄃiWᄃK eĒvqZ Kiab | (D`vniY: Avcbri ũbePZ DĒiW K ntj GᄃK Ⓚ eĒvqZ Kiab)

1. cŁ\_igK ũkᄃv A%ZubK I eva`Zigj-K Kiv nq tKvb mᄃb?
  - K. 1870
  - L. 1891
  - M. 1894
  - N. 1944
2. Aóv`k kZvāx chŚlBsj `vŨi `wi`aI mvavi Y RbMY tKvb cŁZóvᄃb tj Lvcor Ki Z?
  - K. MŁgvi ᄃᄃ
  - L. cveij K ᄃᄃ
  - M. tWg& ᄃᄃ
  - N. tUKvbK`vj ᄃᄃ
3. 1917 mᄃbi ũdmvi AvBᄃb tKvbW cŁle Kiv nq?
  - K. gva`igK ũkᄃvᄃK thvM`Zvm=úbamK.tj i ũbKU Dbᄃ Kivi
  - L. gva`igK ũkᄃvᄃK mKj ũKᄃvᄃi i ũbKU gᄃ Kivi
  - M. t`ᄃki mKj ᄃᄃ tevW`Zᄃ t`qvi
  - N. LEA-Gi nᄃZ cŁ\_igK, gva`igK I Kvi Mvi ũkᄃvi `vqZ;t`qvi
4. QvŨi i cŁYZv I m=ebv Ablyqx gva`igK ũkᄃvi e`e`v Kivi cŁle t`q tKvb KvgW?
  - K. t`úY KvgW
  - L. n`vŨv KvgW
  - M. ũmvi j -bi DW KvgW
  - N. g`vKᄃbqvi KvgW
5. 1944 mᄃbi ũkᄃv AvBᄃb Bsj `vŨi ũkᄃvi ũZbvW mjbv`Ũ `ᄃii cwi Kíbv Kiv nq | GB `li`\_tj v Kx?
  - K. Gij ᄃg>Uvi x, gva`igK I dv`Ũ GWᄃKkb
  - L. Gij ᄃg>Uvi x, gva`igK I KbvUbyqs GWᄃKkb
  - M. cŁ\_igK, gva`igK I KbvUbyqs GWᄃKkb
  - N. cŁ\_igK, gva`igK I dv`Ũ GWᄃKkb

#### Av) msvŨB DĒi cŁæ

1. Aóv`k kZvāx chŚlBsj `vŨi ũkᄃv e`e`vi `eikó" Kx WQj ?
2. cŁ\_igK ũkᄃv AvBb Klb cik nq? Gi dᄃj Kx NᄃU?
3. t`úY KvgWLi mᄃvni k`\_tj v Dᄃj ŨL Kiab |
4. 1944 mᄃbi ũkᄃv AvBᄃb ũkᄃvi Kivᄃg veb`vfm Kx cwi eZŨ NᄃU?



mWVK DĒi : A) 1 | L, 2 | M, 3 | K, 4 | K, 5 | N |



**cW 2**

**ukŋvi eZŋvb Kwŋtgv**

**Dŋik`**

GB cW tkŋl Avciŋb —

- ◆ Bsj v`ŋŋi eZŋvb ukŋvi KwŋtgvMZ `fi ,tj v eYŋv KiŋZ cviŋeb;
- ◆ cŋkŋmŋbK `enkó` tft` gva`igK `ŋŋ ,tj vi tkYŋnefiM eYŋv KiŋZ cviŋeb Ges
- ◆ ukŋvMZ `enkó` tft` gva`igK `ŋŋ ,tj vi tkYŋnefiM eYŋv KiŋZ cviŋeb|

1944 mŋbi ukŋv AvBb Ges Zrcŋi MŋxZ KŋqKŋU mŋthvRbx ukŋsev mŋtkvabx AvBŋbi  
wfiEŋZ `wŋŋq AvŋQ Bsj v`ŋŋi eZŋvb ukŋve`e`v| mŋvŋŋŋZK ukŋv KwŋtgvŋU nŋ`Q  
wbgŋŋc:

2 t\_ŋK 4 eQi cYŋhI qv chš — bŋmŋŋx we`ij q A\_ev cŋŋigK we`ij tŋi  
bŋmŋŋx tkYx A\_ev Mŋŋukŋv

5 t_ŋK 6 eQi cYŋhI qv chš	—	ukŋi ukŋv (Infant class)		eva`Zvgj K I
7 t_ŋK 10-EaŋeQi chš	—	1g `i t cŋŋigK ukŋv		A%ZubK
11 t_ŋK 15/16 eQi chš	—	2q `i t gva`igK ukŋv		

16 -Gi Eŋaŋ	—	3q `lit AŋaKZi ukŋv (further education) Ges D`P ukŋv A_ŋ tUKŋbK`ij Kŋj R, ukŋŋK-ukŋŋY, wekte`ij q cŋŋŋZ. ukŋv		Hŋv`QqK I %ZubK
-------------	---	--	--	--------------------

**cŋŋigK ukŋv**

5 t\_ŋK 7 eQi ce`chŋŋi ukŋi ukŋv cŋK-cŋŋigK ukŋv `ŋŋi Aŋŋŋŋ | cŋŋigK  
`ŋŋi 7 t\_ŋK 11 eQi chŋŋi ,iaZcY`ukŋv Rŋŋŋŋi `ŋŋ ,tj vŋZ t`l qv nŋq \_vŋK/  
cŋŋigK ukŋv eva`Zvgj-K, A%ZubK Ges AŋaKŋsk tŋŋŋŋ mn-ukŋvŋj-K (co-  
educational) | G `ŋŋi ukŋv AZ`ŋŋŋŋŋ Kŋŋ Z Ges AvŋŋŋK ukLb-ŋKlvŋb cŋŋŋZ I  
Kj vŋKŋŋŋŋ i Dci cŋŋŋŋZ |

**gva`igK ukŋv**

Bsj v`ŋŋi gva`igK we`ij q ,tj vŋK cŋkŋmŋbK `enkó` tft` wŋŋŋŋŋ wZb tkYŋŋZ wef`3  
Kiv hŋq:

**ꞑꞑ 1: Bsj ~ꞑUi wkꞑv Kwꞑgv**

Dꞑꞑ wkꞑv

mekꞑe ~ꞑj q	Ktj R Ad GWKKb	Ktj R Ad civ tUKubK	Ktj R Ad dv ꞑ GWjKkb
-------------	-------------------	---------------------------	----------------------------

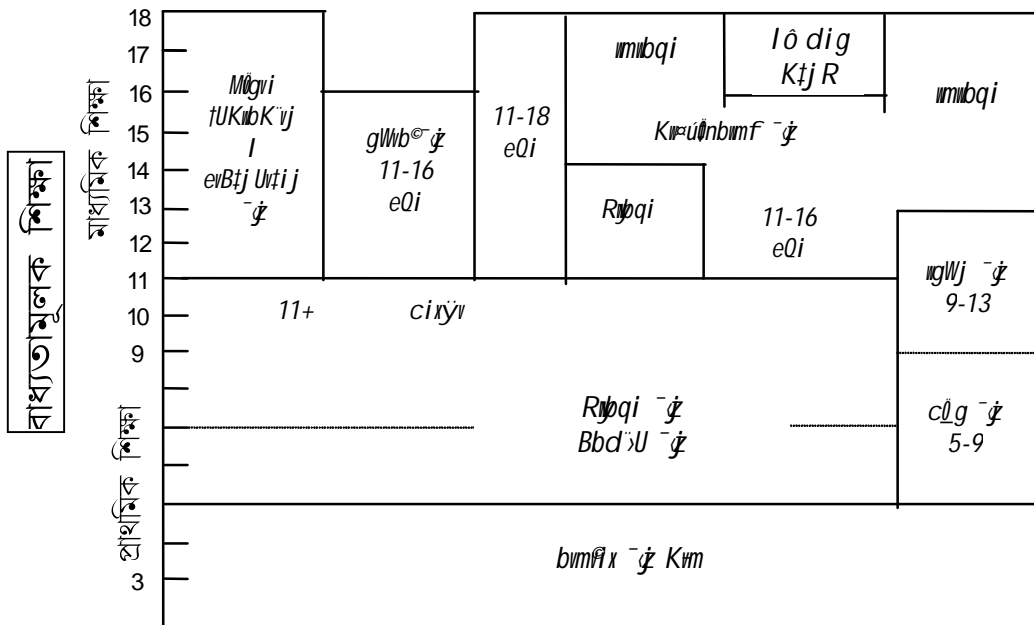

Drn: W. kwi dv LvZb, Zꞑbvgj-K wkꞑvZË; LÜ-2

**1. KivU ev Avꞑij K ve ~ꞑj q**

~ꞑbxq wkꞑv KZ@ꞑ (LEA) KZꞑ.civ Pꞑvj Z GBme ve ~ꞑj tꞑi Øvi mevi Rb Dbꞑꞑ / ve ~ꞑj q civ Pꞑj bv, wkꞑK vbꞑqM A\_ev eiLv'Kiv, Zvꞑ' i DꞑꞑZi cꞑ Dbꞑꞑ Kiv BZ'w hveZxq KivR GBme ve ~ꞑj tꞑi tꞑꞑꞑ LEA Kꞑi ~ꞑK

**2. fj vUvi x gva'igK ve ~ꞑj q**

GBme ve ~ꞑj q LEA KZꞑ civ Pꞑvj Z nqbv Ges G, tꞑv wZb aiꞑbi nꞑ ~ꞑK, h\_v (1) vbꞑꞑꞑ ve ~ꞑj q (Controlled Schools), (2) mꞑvnh'cÜB ve ~ꞑj q (Aided Schools) Ges meꞑkl HKgꞑZ'i ve ~ꞑj q (Special Agreement Schools) / LEA vbꞑꞑꞑ ve ~ꞑj tꞑi tꞑꞑꞑ tꞑvU eꞑꞑi AꞑaꞑKi l tenk Ges mꞑvnh'cÜB ve ~ꞑj tꞑi tꞑꞑꞑ tꞑvU eꞑꞑi Aꞑaꞑ ~ꞑꞑꞑi MðY Kꞑi / GRb' LEA Dꞑꞑ tꞑꞑꞑ ve ~ꞑj tꞑ h\_vꞑꞑg`B-ZZxqusk l GK-ZZxqusk civ Pꞑj KgÜj xi m`m' vbꞑꞑꞑMi AwKivi ivꞑL' meꞑkl HKgꞑZ'i ve ~ꞑj q, tꞑv Avw\_R w`K t\_ꞑK mꞑv'ꞑej ꞑꞑ / ZvB G, tꞑvi tꞑꞑꞑ evBꞑi i

n`it`ci mŷhvm mxigZ| we`ij q,tjvi GKwU b`bZg gvb ivLvi `it`LEA wKQWv  
cfive we`li Kti |

**3. `taxb gva`igK we`ij q**

DBbP=vi, BUb, kamevix, n`it`iv BZ`w` bquU cvej K `tj i RbucŷZv Acwixg |  
cKZcŷŷ cwi cwiKŷZvi Avbŷtj` I AwfRit`Z`i Avofŷi Gme we`ij q GKwU wBR`  
Hwzn` Mto Ztj tQ Ges GB Hwzn` wbtKvj vm nvbŷmi gŷZ “an original English  
contribution to educational practice.” Avakisk cvej K `tjB nj AvevmmK Ges  
Gme we`ij tq wKŷŷv AZ`šl e`qeuj | `tj,tjvi mŷvg ARŷbi wQŷb Dbzgvŷbi  
cŷvmb, Dchŷ wKŷŷK, fiv Qvŷ-wKŷŷK mŷúK, tgavex Qvŷ fiv`BZ`w` KviY Dŷj - L  
Kiv thŷZ cvŷi | tLjvayvi cŷZ Gme `tj LŷB , iæzi cŷvb Kiv nq Ges Gi  
thŷŷKZv cŷtŷej v nq th, ‘The battle of Waterloo was won on the playing field  
of Eton.’ K\_wU i fiv`nj, th cŷZthvMZvgj-K gŷbvŷve, k;Ljv I tbZŷzi ,ŷY  
I quŷv j y hŷ tRZv mŷe nŷquj tmB , Y cvej K `tj i Qvŷ Rŷetb AwRŷ nŷquj |

cŷvmbK w`K Qvov wKŷŷMZ (academic) w`K t`tKI Bsj`vŷŷi gva`igK  
we`ij q,tj vŷK wZbŷU cŷvb fivM fivM Kiv thŷZ cvŷi | h\_v- Mŷgvi `tj, gWvb`ŷ I  
tUKwK`ij `tj | wbtgŷ,tjvi mŷŷŷB eYŷv t`qv nj :

Mŷgvi `tj eŷ kZvax atŷi Mŷgvi `tj Bsj`vŷŷi gva`igK wKŷŷv `tj wKŷŷv vb Kti  
AvmtQ | G,tjv Hwzn`evnx we`ij q etj cwiwPZ | Mfvi Avb ARŷ I ey`gEv Ges  
tbZŷzi ,Y weKŷk wKŷŷŷ`i mŷvqZv KivB GB `tj,tjvi j`ŷ | Gme `tj  
wKŷŷvKj 7 ermi (11-18 ermi eqm Aewa) | Zŷe th mKj wKŷŷv\_16 ermtŷi i cŷi  
Gme `tj `vŷK Zviv Mŷgvi `tj i mŷeP ‘Sixth form’ G 1-3 ermi AwZevwZ Kti  
tKvb wŷtq wŷkŷl A nevi gvbŷm |

mŷaviYZ wekle`ij tq Aa`qŷbi ce`cŷwZ cŷvŷbi cŷZ j`ŷ tŷL Mŷgvi `tj i  
wKŷŷvKgŷŷP wbaŷY Kiv nq | Zŷe cŷŷŷY Ktj R, tUKwK`ij Ktj R I Ab`vb` D`P  
tckvgj-K mŷvŷ Mŷgvi `tj i cv`mug cŷŷŷb cfive we`li Kti | BŷŷwR fivŷ I  
mŷwZ, wŷ`kx fivŷ, KwK`ij fivŷ, c`v`ŷAvb, imvqb, RŷewAvb, MŷYZ, BwZvnm,  
fŷMj, wŷi Kj v, mŷxZ BZ`w` wŷl q Mŷgvi `tj i Aŷŷŷ | eZŷŷb AŷbK Mŷgvi `tj  
A\_ŷwZ, `vcZ`we`v, cŷKŷkj weAvb, Kwŷi Mŷi Aŷb, ewYR` BZ`w` cv` wŷl qŷŷc  
`vb tctqŷQ |

gWvb`ŷt G,tjv gj-Zt cixŷŷvgj-K we`ij q | AvaybK A\_ŷwZK I kŷ Rŷetbi mtŷ  
mŷwZ tŷL GB `tj,tjv Zŷ`i Kvŷŷg cwiPij bv Kti `vŷK | wj, Kj -Kiv Lvbv,  
t`vKvb, e`emvq cŷZŷvb, hŷbevb, Lvgvi cŷŷŷi Rb` ga`g `tj i kŷ`ŷZv DcŷŷMx  
wKŷŷv gWvb`ŷ,tj vZ t`qv nq | GB wKŷŷv j`ŷ nŷv Rŷebag` I Aemi wŷbv`ŷbi  
mŷvqK Avb I `ŷZv cŷvb | GB `tj,tjvi wKŷŷvug nŷv BŷŷwR, BwZvnm, fŷMj,  
mgvRcvW, `ŷ`, kvŷwŷi K wKŷŷv, AsK, weAvb, wŷi, mŷxZ, evMvbPPP, BZ`w` | cŷvb





### cv#VvEi gj`iqb - 2

#### A) eU ubePbx ckae

m#WK DEi #bt` Rgj-K Aq#i#U#K eE#mqZ Kiab | (D`vniY: Avcbvi ubeP#Z DEi#U K ntj GtK **K** eE#mqZ Kiab)

1. Bsj `itU 5 t\_#K 6 eQi cY#l qv chS#k#q#vi t#q#i tKv#U c#h#r?
  - K. GB `#i i #k#q#v A%#Z#bK
  - L. GB `#i i #k#q#v eva`Z#q#j-K
  - M. GB `#i i #k#q#v c#k-c#l\_#gK `#i i A#M#Z
  - N. Dc#i i me\_#ij
2. #Kvb ai#bi gva`#gK #e`ij tqi tgvU e`tqi A#t#K#i#l tenk e`vq#vi LEA enb K#i?
  - K. #bq#s#Z #e`ij q
  - L. m#v#h`c#B #e`ij q
  - M. K#D#U #e`ij q
  - N. #e#k#l H#K#t#Z`i #e`ij q
3. #Kvb `#j i #k#q#v K#h#e#g Av#b#K A\_#b#Z#K I k#R#e#t#bi m#t\_ m#z#Z#c#Y?
  - K. M#g#v#i `#j
  - L. g#W#Y`#j
  - M. t#U#k#b#K`ij `#j
  - N. K#u#b#m#f `#j
4. M#g#v#i `#j i sixth form-G K#v#i t#j L#v cov K#i?
  - K. 11 eQ#i i #b#P#i eqm#i#v
  - L. 11 t\_#K 16 eQ#i i eqm#i#v
  - M. 16 t\_#K 18 eQ#i i eqm#i#v
  - N. 18 eQ#i i Dc#i i eqm#i#v
5. #e#f#b#e c#k#z#i gva`#gK #e`ij q#k G#K#B `#j i Av#l Z#v#q Av#b#v n#q#t#Q t#K#v#U#Z?
  - K. K#u#b#m#f `#j
  - L. g#v#e#t#j U#v#i#j `#j
  - M. ev#B#t#j U#v#i#j `#j
  - N. g#W#Y`#j

#### Av) m#v#q#B DEi ckae

1. Bsj `itU#i eZ#g#v#b #k#q#v K#v#t#g#v#i eq#t#e#g #f#i#E#K `#i\_#t#j#v D#t#j#L Kiab |
2. Bsj `itU#i f#j#v#U#v#i#x gva`#gK #e`ij q\_#t#j#v#i t#k#Y#x `e#n#k#o` D#t#j#L Kiab |
3. Bsj `itU#i c#v#e#j#K `#j\_#t#j#v#i\_#i#z#j#l `e#n#k#o` D#t#j#L Kiab |



#### m#WK DEi

A) 1 | N, 2 | K, 3 | L, 4 | M, 5 | L |



metklA`i` i` ubtq MmVZ nq` vbxq` uk`qv KZE`q - Gj B G| cAZuW Gj B G Zvi cAvb  
KgmPe ubtqvM Kti| L.E.A.-i` uk`qvbxZ ifcvmqZ KivB Zvi` vqZi| Zvi Aaxtb  
itqtQb Ab`vb` KqPvix Ges me`ij q` cwi` kRe,` (Giv L.E.A. Inspector - H.M.I.  
bb)| Gj B G uk`qv evtRU` Zwi Kti| cY% KivDwYtj i` vqZi; n`Q Gj B G-i Rb`  
A\_`ms`vb Kiv| mzi`vs KivDwYtj i` GKiu mvaviY KZQ;\_vKtj I` `bw`b Kivh`q`i`  
Gj B G cKZct`q` `vqE`kvmmZ|

KivDwU I` KivDwU etiv KivDwYj Qvovl AvA`ij K` wfvE`tZ uk`qv cP`ov` mgsnZ Kivi Rb`  
itqtQ Omwvfk`vj A\_wi`uU| KivDwU KivDwYj, etiv KivDwYj, me`ij q` cwi` Pij K` mfvi  
cAZvba, uk`qK I` Ab`vb` metklA` ubtq GB cAZovb MmVZ| mvaviYfvte Gj B G-i  
ubt``k`B GB cAZovb KivR Kti|

Gj B G-i cAvb` vqZi` gta` itqtQ - (K) cU`vgK, gva`vgK Ges gva`vgKvE`i  
uk`qv (mekpe`ij q` e`vZti`k) e`e`vi mgsnZ cwi` Pij bv; (L) bvm`fx uk`qvq Drmiv I`  
mivv`vb; (M) vbxq` wfvE`tZ uk`qv cwi` Kiv`v` Zwi; (N) vbxq` uk`qv Ki Av`vq I`  
eUv; (O) AA`tj i` gta` temiKvix me`ij q` I` PivP`cwi` Pwv Z me`ij q` t`jvi m`z  
mst`hM i`qv; (P) me`ij q` cwi``k`bi e`e`v; (Q) me`ij q` cwi` Pij K` mfvi m`z  
wfvE`tZ uk`qK ubtqvM Ges L.E.A. I` uk`qK mvgvzi` thS` cwi` I` i` gva`tg uk`q`k`i  
teZb`ug I` Kiv`Ri ubqgvej`x cU`qb; (R) Qv`Kj`vY e`e`vcbv; (S) gS`Bi t`\_t`K  
miKvix mivv`v` MhY I` eUv Ges (T) vbxq` cU`qvRbv`v`v`i me`ij q` vcb I`  
uk`qv`v`v`bi Db`qb| cAZuW L.E.A.-Gi ubt`P` `q` itqtQ cwi` Pij K` mfvi (Board of  
Governors or Management)| cwi` Pij K` mfvi` vq` vqZi; ubf`P` Kti me`ij q` i` Pwi`t`i`  
Dci| temiKvix me`ij q` i` cwi` Pij K` mfvi` vqZi I` Av`Kvi A`bK` temk| `q` i`  
Avf`šli`xY c`kv`tb Aek` cAvb uk`qK I` uk`qK cwi` I` e`vck` q`gZv` t`f`vM Kti b|

**~P1 2: Bsj ~tUi ~k~v c~kmb Kw~gv**

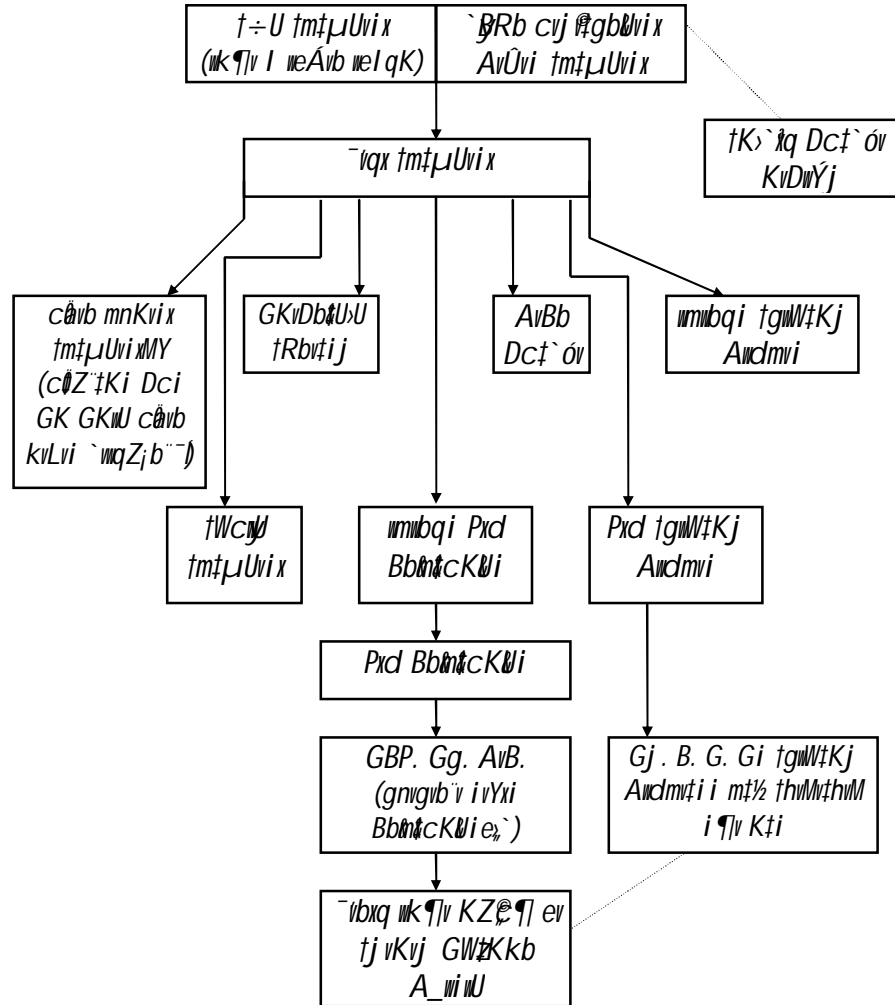





### cvtVvEi gj`vqb - 3

#### A) eú ubePbx cktæ

mivK DËi vbt`Rgj-K Aqji vutK efvvqZ Kiab | (D`vniY: Avcbvi ubePZ DËi vU K ntj GtK  efvvqZ Kiab)

1. H.M.I.-iv Kvi mt½ hy?  
 K. KvDvU KvDvYj  
 L. LEA  
 M. vkvvgšxi `Bi  
 N. UGC
2. AvAvj K vfiEz vkvv KgvPi mgšq Kti tKvbu?  
 K. LEA  
 L. vvvfkbvj A\_viu  
 M. KvDvU KvDvYj  
 N. etiv KvDvYj
3. tKvbu tK`iq KZe:qji `vqZ?  
 K. vkvv kvvkvv Dchj thvM`Zv vbuDZ Kiv  
 L. vkvv vbtqvM Kiv  
 M. vkvv Ki Av`vq I evb Kiv  
 N. ve`ij q `vcb I vkvv gvbi Dbqb Kiv
4. tKvbu LEA-Gi AšM?  
 K. `z cvi Pvj K mfv  
 L. H.M.I.  
 M. vvvfkbvj A\_viu  
 N. UGC

#### Av) msvvB DËi cktæ

1. Bsj vti vkvv cvmb I e`evcbvi tvt tK`iq KZe:qji `vqZ; DtvL Kiab |
2. Bsj vti vkvv cvmb I e`evcbvi tvt `vbxq KZe:qji `vqZ; DtvL Kiab |
3. Bsj vti vkvv cvmb I e`evcbvq `vbxq KZe:qji ,iaz; DtvL Kiab |



#### mivK DËi

A) 1 | M, 2 | L, 3 | K, 4 | K |



6. tKvb `tj i uk`lv KgmP mvavi YZ mekpe`ij tqi ce@t`nZgj-K ntq \_vtK?

- K. M@gvi `tj
- L. K`u@nbimf `tj
- M. gWvY@`tj
- N. tUKvbK`ij `tj

7. mKj cKvi mvgvRK tkYxi QvTQvT`i uk`lvi jt`l` tKvb `tj c@Z@v Kiv nq?

- K. cvewj K `tj
- L. gWvY@`tj
- M. tUKvbK`ij `tj
- N. K`u@nbimf `tj

8. uk`lv nbqstYi Povs`AvaKvi AvBbMZ tKvbUj Dci b`-P

- K. LEA
- L. uk`lv gsj`Bi
- M. KvDvU KvDvYj
- N. etiv KvDvYj

**Av) iPbvj-K ckae**

1. Bsj`vtUi c@\_vgK I gva`vgK uk`lvi mgueKvk D`tj L Kiab|
2. 1944 m`bi uk`lv AvBtbi , iazcY`K , tjv e`vL`v Kiab|
3. Bsj`vtUi eZg`vb uk`lv KvVtgvv `li , tjv eY@v Kiab|
4. gva`vgK me`ij q , tjvi c@kvmibK tkYmeFvM eY@v Kiab|
5. gva`vgK me`ij q , tjvi GKv`WvgK tkYmeFvM eY@v Kiab|
6. Bsj`vtUi uk`lv c@kvmib uk`lv gsj`vj tqi , iazj I `vncZj eY@v Kiab|
7. Bsj`vtUi uk`lv c@kvmib `vbxq KZE`tji , iazj I `vncZj eY@v Kiab|



**mWK DEi**

- A) 1| L, 2| N, 3| N, 4| K, 5| M, 6| K, 7| N, 8| L|

**M&CÄx**

Aggarwal, J.C., *National Policy on Education*, New Delhi : Arya Book Depot, 1979.

Cramer, J.F. and Browne, G.S., *Contemporary Education*, New York : Harcourt, Brace & World, Inc, 1965.

Joshi, R.N., *Education Elsewhere & Here*, Bombay : Bharatiya Vidya Bhavan, 1979.

Sodhi, T.S., *A Textbook of Contemporary Education*, Dhaka : Associated Business Corporation, 1998.

ᄡ, DclvKvšl Zj bvgj-K ᄡᄡv, Kvj KvZv : GWKkbvj eᄡ Kičvtikb, 1974|

eᄡ ᄡvcaᄡv, ᄡRᄡZcᄡᄡ. fvi Zxq ᄡᄡvi BvZnvᄡ I mᄡᄡZK mgmᄡ, Kvj KvZv : ᄡᄡv cᄡvkbx, 1977|

ivq, ARq. ᄡᄡvq behᄡ, Kvj KvZv t cᄡᄡgeᄡ ivRᄡ cᄡᄡ, 1986|

nvqvī tmᄡKŪvix GWKkb cᄡRᄡ, ᄡᄡv gšᄡvq, ᄡᄡvᄡᄡZ I ᄡᄡv eᄡ ᄡcbv, XvKv 1999|

nvqvī tmᄡKŪvix GWKkb cᄡRᄡ, ᄡᄡv gšᄡvq, ᄡᄡvi BvZnvᄡ I Zj bvgj-K ᄡᄡv, XvKv 1994|