

# Ինչպե՞ս կառավարել և ղեկավարել դպրոցը

*Principles of Educational Administration and Management*

EDM 2351

Գրքի հեղինակը



Երևանի պետական համալսարանի  
Կրթական կառավարման և մեթոդական կենտրոնի



# **ikjv ckb I e'e tcbvi gj-bwz**

EDM 2351

## **GgGW tcbw**

### **ckvkKvj**

clg gyY: Wtm<sup>+</sup>, 2000

clj: gyY: 2004, 2005

clj: gyY: Rvbw, 2012

clj: gyY: Gicj, 2014

### **cö`**

KvRx mvBd'xb&AveYm

### **KvúDUvi KúúR Ges WwUvc**

tgw: RvKi trvmb

© **evsj v`k D:gy' nekpe`vj q**

ISBN 984-34-0060-7

### **ckvkbvq**

ckvkbv, gyY I weZiY wefvM

evsj v`k D:gy' nekpe`vj q

MvRxcj- 1705|

### **gyY**

evsj v evRvi tcb GÜ cvevj tKkb

53 b\_ek nj tivW, evsj v evRvi

XvKv- 1100|

# tKvmeB AbgyiY Kivi KuhRi ciqk©

## icq ikyvLx©

Dgy ikLb cxwZ wbfP GgGW ikyv tcmMgti fivZnl qvi Rb" **ġ Ae GwKkb** AvcbvK Avšhi K Awfb`b Rvbt"Q| ikŋlv ckvmb I e`vcvri gj-bwZ (EDM 2351) tKvmeBw GgGW tcmMgti wZxq chŋqi wtklvqb tŷtI GKwU tKvmeB| GB tKvmp Df`k`nj ikŋlv ckvmb I e`vcvri mautK`cU\_wgK avi Yv jvtf AvcbvK mnvqZv Kiv| Avkv Kiv hvq, Avcvb GB eBtq Dc`wcz cvV,tjvi gva`tg weliU mautK`mVK avi Yv jvtf KiZ myg nteb Ges ikyv ckvmb I e`vcvri tŷtI bZb wPšlariv I `wofwz ARŋb myg nteb|

G tKvmeBwU ciW` weliq gj-Z: ikyv ckvmb I e`vcvri tŷtI ,iazcy© cŋqvRbxq etj wewpZ KtqKwU tŷtI tK`Kti wewfbacvVi gva`tg Dc`vcv Kivi tPov Kiv ntqtQ| Avkv Kiv ntqtQ Avcvb hw` G,tjv gtbvthw mnkvti cvV Kti b Zte GZ` weliq GKwU mvgwMK I `Q avi Yv jvtf mg`nteb|

## EDM 2351 tKvmeB

### ciW I Abgytbi tŷtI Avcbv`i KiYq ik?

- tKvmeBwU cxwZi gj- K\_vB nj wbtR wbtR cto tKlv Ges wbtRi tPovq tKlv| Ab`K\_vq, G cxwZi gva`tg ikyv`r`wR`wqtZj wbtRi mjevav gtZv mgtq tKlv Kivr wbtqwrZ nb| e`ġ G Df`k`tK mvgtb tiLB **ġ Ae GwKkb**-Gi wewfbacvKvmp eB,tjv iwPZ| GtZ fivMZ HK`iyv Kti cvtVi weliq`tK KZ,tjv BDwbU fivM Kiv ntqtQ| Avevi BDwbU,tjv tK KZ,tjv cvtV fivM Kiv ntqtQ| cŋZwU cvV cU\_wgKfite GKevi cotZ Avcbvi 40-45 wgvbu mgq jvMte etj ati tblqv ntqtQ| cŋZwU BDwbUi tktI Avcvb wbtRB wbtRi cvV AMwZ gj`vqb KiZ cvi teb| G Rb` cvtVi tktI cvtVvEi ckgvjv i tqtQ|
- tKvmeB covi mgq wK wK Kivr I ci ,iazjw tZ nte?
  - cvtVi gj`vqtb ckg,tjvi DEi wbtR wbtR Kiab| Avcbvi DEi,tjv mwK nj wK bv, Zv cvtVi weliq`chŋyY Kti wbtRB wvavY Kiab|
  - cvtVvEi gj`vqtb me,tjv cŋk`e mwK ntj cieZr`BDwbU GwMtg hvb|
  - Avcbvi DEi,tjv mwK bv ntjv cvV,tjv cob| cov tkl ntj cvtVvEi gj`vqb ckg,tjvi DEi Kiab| DEi mwK ntj ci ci cvtV GwMtg hvb|
  - tKvb cvtV me,tjv cŋk`e DEi mwK bv ntj tm cvtVi wv`ŋ Ask Avevi cob| Gfite cŋZwU BDwbUi cvV,tjv tkl Kiab|

eBwU tZ th mg`lwb`Rbvj-K wPý e`eyZ ntqtQ tm,tjv nj :

- |   |            |   |                |
|---|------------|---|----------------|
|  | DxwZ       |  | cvtVvEi gj`vqb |
|  | cvV weliwZ |  | mwK DEi        |

- cvV-mnvqK KgŋRv
  - GB eBwU Qvovl **ġ Ae GwKkb**-Gi mwewr ZEjearv AvtqwrZ `vbxq GgGW ÷wv tmUvri Avcbvi Rb` cŋZ gvtm (2q-4`A\_ev 1g-3q i`µeri) `BwU wDvUwvi qjv tmktbi e`v`v MŋY Kti tQ| Gme tmktb thvM w`tq Avcvb eBwU tKvb Ask ev cvV cotZ wMtg tKvb mgm`vq cotj tm weliq cŋqvRbxq ciqk`© wbt`Rbv MŋY KiZ cvtI b|
  - ti wv I wvftZ cŋZ mBvtn Avcbvi Rb` cvV weliq`wv`wEK mnvqK tmktbi e`v`v i tqtQ| Avcvb wvavv Z mgtq Nti efm Gme tmktb AskMŋY Kti msvk`w tŷtI Avcbvi mg`x KiZ cvtI b|







**cW 1**

**cġvmb I e'e`vcbv aviYv I msÁv**

**Dt'ik**

GB cW tkfI Avcib—

- cġvmb Ges e'e`vcbv kã `vbi A\_@j tZ Ges e'vL'v I wektkY Ki tZ cvi teb;
- kã `vbi e'rcuE m'úK@j tZ cvi teb Ges
- cġvmb I e'e`vcbv cvi `úwi K m'úK@bifcY Ki tZ cvi teb|

**cġvmb- A\_@ msÁv**

cġvmb kãu eü c@pib| hLb t\_#K gvby `j ex ntq emevm Ki tZ wklj, ZLb t\_#KB cġvmbi c@qvRbxqZv cwi j wŸZ nj | thLvfbB tKvb `j ev mSMVb we`gvb, tmLvfbB cġvmbi Dcu`wZ j Ÿ Kiv hvq| cġvmbi BstiwR c@Zkã Administration| Ad t\_#K we'ObæKti Ministration kãu e'rcuE MZ A\_@ w\_#K ZvKvtj Avgiv t`L tZ cve Gi A\_@n'Q 0Kv'iv Rb` gtbvthvM t`qv0 ev 0hZæKiv0| GB A\_@cġvmbtK Avgiv tmevgj-K KivR ev c@uqv ej tZ cwi | tKvb c@Z0vb ev mSMVtbi j Ÿ ev Dt'ik` AR#bi Rb` KivR KivtK tevSvq| Aciw`#K, evsjv cġvmb ktãi A\_@Kitj `wvq c0+ kvmb| GLvfb kvmb kãu kvw`c0v'bi BwZ enb Kti | hv I cġvmbt vbqg, bwiZ I k;Ljvi cġe RiwZ, Z\_wic AvaybK A\_@cġvmbi tmevgj-K w KivB c@v' tctq Avm'Q| mSMVb gv'IB Dt'ik`g'x| c@Zw mSMVb wKQybw`0 j t'Ÿ'i w\_#K avegib| j Ÿ ev Dt'ik` AR#bi Rb` MpxZ m'p'q'šZ I m'z'wi Pwvj Z e'e`vi bvgB cġvmb|

**e'e`vcbv- A\_@ msÁv**

The International Encyclopedia of Higher Education Vol-6 G e'e`vcbv th msÁv t`qv ntqtQ Zvuj, "Management may be defined as the process of activating and integrating the capacities of an enterprise to attain optimum results with a minimum expenditure of resources."<sup>1</sup> A\_@ `fZg m'úf`i miv'vth` mtefEg dj v'vj cvevi j t'Ÿ' tKvb c@Z0v'bi mvg\_#K Ktg'Ÿ B I m'g'šZ Kiv| e'e`vcbv g'tj itqtQ e'w<sup>3</sup> ev personnel Ges Dt'ik` nt'Q mtefEg e'w<sup>3</sup> ev Kge' wbtqvM Ges mtefEg e'w<sup>3</sup> ev Kge' wBKU t\_#K me'w'K dj j'v'f| The World Book Encyclopedia, Vol- 8 G ejv ntqtQ, "Management is the art and practice of managing a business or industry . . . . It may be described as "making do" or making the best of available resources."<sup>2</sup> e`ZctŸ e'emv, emYR` Ges wki t'Ÿ'IB e'e`vcbv kãu e' c0g AwefE|

<sup>1</sup> The International Encyclopedia of Higher Education, Vol-6. p-1692

<sup>2</sup> The World Book Encyclopedia, Vol-8, P-73



### čkymb I e'e-vcbv

čkymb I e'e-vcbvi avi Yv m<sup>3</sup>útk<sup>3</sup>KLbI KLbI w<sup>3</sup>q<sup>3</sup>w<sup>3</sup> Ges gbl<sup>3</sup>ḫ<sup>3</sup> i gḫ<sup>3</sup> cv<sup>3</sup> R<sup>3</sup> t<sup>3</sup> Lv hvq| e<sup>3</sup>sj<sup>3</sup>vq e<sup>3</sup>ycw<sup>3</sup>EMZ A<sup>3</sup>č<sup>3</sup>čkymb n<sup>3</sup>Q K<sup>3</sup>vD<sup>3</sup>čK čk<sup>3</sup>ó.<sup>3</sup>ev DrKó.i.čc K<sup>3</sup>vR KičZ eva<sup>3</sup> K<sup>3</sup>iv Ges č<sup>3</sup>q<sup>3</sup>vRčb<sup>3</sup> k<sup>3</sup>w<sup>3</sup>l<sup>3</sup>w<sup>3</sup>ar<sup>3</sup>b<sup>3</sup> K<sup>3</sup>iv| GLvčb<sup>3</sup> k<sup>3</sup>ymb k<sup>3</sup>āu<sup>3</sup> AwaKZi č<sup>3</sup>āvb<sup>3</sup> čv<sup>3</sup>Q| Bst<sup>3</sup>i<sup>3</sup>w<sup>3</sup>R Administration k<sup>3</sup>āu<sup>3</sup> e<sup>3</sup>ycw<sup>3</sup>EMZ A<sup>3</sup>č<sup>3</sup>č<sup>3</sup>tmev<sup>3</sup> ev K<sup>3</sup>j<sup>3</sup> v<sup>3</sup>Yg<sup>3</sup>č<sup>3</sup>-K D<sup>3</sup>č<sup>3</sup>i<sup>3</sup>k<sup>3</sup> w<sup>3</sup>b<sup>3</sup>č<sup>3</sup>q<sup>3</sup> t<sup>3</sup>K<sup>3</sup>iv w<sup>3</sup>K<sup>3</sup>Q<sup>3</sup>j<sup>3</sup> m<sup>3</sup>g<sup>3</sup>ze<sup>3</sup>e<sup>3</sup>-vcbvč<sup>3</sup>K<sup>3</sup> tev<sup>3</sup>Svq<sup>3</sup>| GLvčb<sup>3</sup> t<sup>3</sup>mev<sup>3</sup> ev K<sup>3</sup>j<sup>3</sup> v<sup>3</sup>Y k<sup>3</sup>āu<sup>3</sup>i č<sup>3</sup>āvb<sup>3</sup> AwaK<sup>3</sup>| Aa<sup>3</sup>g<sup>3</sup>v e<sup>3</sup>ú<sup>3</sup>t<sup>3</sup>q<sup>3</sup>č<sup>3</sup>i<sup>3</sup>B čkymb Ač<sup>3</sup>q<sup>3</sup>v e'e-vcbv k<sup>3</sup>āu<sup>3</sup> e<sup>3</sup>en<sup>3</sup>i<sup>3</sup>i č<sup>3</sup>č<sup>3</sup>Z č<sup>3</sup>č<sup>3</sup>Y<sup>3</sup>Z<sup>3</sup>v<sup>3</sup> j<sup>3</sup> q<sup>3</sup> K<sup>3</sup>iv hvč<sup>3</sup>Q| t<sup>3</sup>K<sup>3</sup>iv t<sup>3</sup>K<sup>3</sup>iv w<sup>3</sup>q<sup>3</sup>w<sup>3</sup>č<sup>3</sup> č<sup>3</sup>k<sup>3</sup>vmK k<sup>3</sup>āu<sup>3</sup>i č<sup>3</sup>w<sup>3</sup>i e<sup>3</sup>t<sup>3</sup>Z<sup>3</sup>č<sup>3</sup>meK k<sup>3</sup>āu<sup>3</sup> e<sup>3</sup>en<sup>3</sup>i<sup>3</sup>i č<sup>3</sup>q<sup>3</sup>č<sup>3</sup>w<sup>3</sup>Z<sup>3</sup>|

avi Yv w<sup>3</sup>nm<sup>3</sup>vč<sup>3</sup> čkymb k<sup>3</sup>āu<sup>3</sup> Ač<sup>3</sup>bK č<sup>3</sup>č<sup>3</sup>P<sup>3</sup>xb| m<sup>3</sup>ḡ<sup>3</sup>-AZ<sup>3</sup>xZ t<sup>3</sup>č<sup>3</sup>K<sup>3</sup> i<sup>3</sup>vó<sup>3</sup> č<sup>3</sup>w<sup>3</sup>i<sup>3</sup> P<sup>3</sup>v<sup>3</sup>j<sup>3</sup> b<sup>3</sup>v<sup>3</sup>, t<sup>3</sup>mb<sup>3</sup>v<sup>3</sup>en<sup>3</sup>w<sup>3</sup>bx<sup>3</sup> ev ag<sup>3</sup>č<sup>3</sup> č<sup>3</sup>č<sup>3</sup>Zō<sup>3</sup>v<sup>3</sup> č<sup>3</sup>w<sup>3</sup>i<sup>3</sup> P<sup>3</sup>v<sup>3</sup>j<sup>3</sup> b<sup>3</sup>v<sup>3</sup>i t<sup>3</sup>q<sup>3</sup>č<sup>3</sup>i<sup>3</sup> k<sup>3</sup>āu<sup>3</sup> e<sup>3</sup>e<sup>3</sup>ü<sup>3</sup>Z n<sup>3</sup>č<sup>3</sup> Avm<sup>3</sup>Q<sup>3</sup>j<sup>3</sup>| Ac<sup>3</sup>i<sup>3</sup>w<sup>3</sup>č<sup>3</sup>K e'e-vcbv k<sup>3</sup>āu<sup>3</sup>i D<sup>3</sup>č<sup>3</sup>e<sup>3</sup> n<sup>3</sup>č<sup>3</sup>č<sup>3</sup>Q<sup>3</sup> w<sup>3</sup>k<sup>3</sup>i<sup>3</sup>-w<sup>3</sup>e<sup>3</sup>f<sup>3</sup>č<sup>3</sup>e<sup>3</sup>i č<sup>3</sup>i<sup>3</sup>| GB k<sup>3</sup>āu<sup>3</sup> w<sup>3</sup>k<sup>3</sup>i<sup>3</sup> č<sup>3</sup>č<sup>3</sup>Zō<sup>3</sup>v<sup>3</sup>, e<sup>3</sup>em<sup>3</sup>v Ges Private Sector ev t<sup>3</sup>emi<sup>3</sup> K<sup>3</sup>vix m<sup>3</sup>s<sup>3</sup>-v<sup>3</sup>i m<sup>3</sup>č<sup>3</sup>½ AwaKZi m<sup>3</sup>ú<sup>3</sup>ḫ<sup>3</sup>| q<sup>3</sup>č<sup>3</sup>ḡ<sup>3</sup>e<sup>3</sup>e<sup>3</sup>em<sup>3</sup>vqx<sup>3</sup> ev ew<sup>3</sup>YK m<sup>3</sup>ú<sup>3</sup>ú<sup>3</sup>vč<sup>3</sup>q<sup>3</sup>i w<sup>3</sup>b<sup>3</sup>R w<sup>3</sup>b<sup>3</sup>R e<sup>3</sup>em<sup>3</sup>v č<sup>3</sup>w<sup>3</sup>i<sup>3</sup> P<sup>3</sup>v<sup>3</sup>j<sup>3</sup> b<sup>3</sup>v<sup>3</sup> c<sup>3</sup>x<sup>3</sup>v<sup>3</sup>Z t<sup>3</sup>č<sup>3</sup>K e'e-vcbv k<sup>3</sup>āu<sup>3</sup>i Av<sup>3</sup>w<sup>3</sup>e<sup>3</sup>f<sup>3</sup>č<sup>3</sup> | "The methods of management have developed from the comparatively simple, direct way of running a business that merchants and owners of small factories practised in the 1700's".<sup>3</sup>

e'e-vcbv k<sup>3</sup>āu<sup>3</sup> Drc<sup>3</sup>v<sup>3</sup>b<sup>3</sup>g<sup>3</sup>ḡ<sup>3</sup>x (Production Oriented) Ges K<sup>3</sup>g<sup>3</sup>ḡ<sup>3</sup>ḡ<sup>3</sup>x (Activity Oriented)| Ac<sup>3</sup>i<sup>3</sup>w<sup>3</sup>č<sup>3</sup>K č<sup>3</sup>k<sup>3</sup>vmč<sup>3</sup>bi<sup>3</sup> w<sup>3</sup>ḡ<sup>3</sup> w<sup>3</sup>e<sup>3</sup>wa<sup>3</sup> w<sup>3</sup>b<sup>3</sup>q<sup>3</sup> ev Av<sup>3</sup>B<sup>3</sup>b<sup>3</sup> K<sup>3</sup>v<sup>3</sup>b<sup>3</sup>y č<sup>3</sup>č<sup>3</sup>q<sup>3</sup>vč<sup>3</sup>M<sup>3</sup>i<sup>3</sup> w<sup>3</sup>č<sup>3</sup>K AwaKZi w<sup>3</sup>b<sup>3</sup>x (Application of Rules and Regulations)| č<sup>3</sup>k<sup>3</sup>vmč<sup>3</sup>bi<sup>3</sup> K<sup>3</sup>v<sup>3</sup>R b<sup>3</sup>w<sup>3</sup>Z w<sup>3</sup>ba<sup>3</sup>f<sup>3</sup>Y, č<sup>3</sup>w<sup>3</sup>i<sup>3</sup> K<sup>3</sup>i<sup>3</sup>b<sup>3</sup>v<sup>3</sup> č<sup>3</sup>v<sup>3</sup>q<sup>3</sup>b, w<sup>3</sup>m<sup>3</sup>x<sup>3</sup>v<sup>3</sup>š<sup>3</sup>i<sup>3</sup> M<sup>3</sup>ḡ<sup>3</sup>Y, č<sup>3</sup>w<sup>3</sup>i<sup>3</sup> P<sup>3</sup>v<sup>3</sup>j<sup>3</sup> b<sup>3</sup> Ges w<sup>3</sup>b<sup>3</sup>q<sup>3</sup>š<sup>3</sup>Y| e'e-vcbvi K<sup>3</sup>v<sup>3</sup>R w<sup>3</sup>b<sup>3</sup>e<sup>3</sup>f<sup>3</sup>č<sup>3</sup> w<sup>3</sup>v<sup>3</sup>q<sup>3</sup>Z; č<sup>3</sup>v<sup>3</sup>j<sup>3</sup>b<sup>3</sup>| č<sup>3</sup>k<sup>3</sup>ymb t<sup>3</sup>K<sup>3</sup>iv w<sup>3</sup>b<sup>3</sup>ḡ<sup>3</sup> j<sup>3</sup> q<sup>3</sup> AR<sup>3</sup>č<sup>3</sup>bi<sup>3</sup> R<sup>3</sup>b<sup>3</sup> b<sup>3</sup>w<sup>3</sup>Z w<sup>3</sup>ba<sup>3</sup>f<sup>3</sup>Y I č<sup>3</sup>w<sup>3</sup>i<sup>3</sup> K<sup>3</sup>i<sup>3</sup>b<sup>3</sup>v<sup>3</sup> č<sup>3</sup>v<sup>3</sup>q<sup>3</sup>b K<sup>3</sup>i<sup>3</sup>, e'e-vcbvi K<sup>3</sup>v<sup>3</sup>R t<sup>3</sup>m<sup>3</sup>B b<sup>3</sup>w<sup>3</sup>Z I č<sup>3</sup>w<sup>3</sup>i<sup>3</sup> K<sup>3</sup>i<sup>3</sup>b<sup>3</sup>v<sup>3</sup> ev<sup>3</sup>č<sup>3</sup>v<sup>3</sup>q<sup>3</sup>b K<sup>3</sup>iv| e<sup>3</sup>-Zč<sup>3</sup>č<sup>3</sup>q<sup>3</sup> č<sup>3</sup>k<sup>3</sup>ymb I e'e-vcbv k<sup>3</sup>ā<sup>3</sup> w<sup>3</sup>ḡ<sup>3</sup> Gč<sup>3</sup>K Ac<sup>3</sup>i<sup>3</sup>i<sup>3</sup> m<sup>3</sup>vč<sup>3</sup> N<sup>3</sup>w<sup>3</sup>b<sup>3</sup>ō<sup>3</sup>f<sup>3</sup>vč<sup>3</sup>e m<sup>3</sup>ú<sup>3</sup>ḫ<sup>3</sup>| č<sup>3</sup>k<sup>3</sup>vmč<sup>3</sup> th<sup>3</sup>g<sup>3</sup>b č<sup>3</sup>w<sup>3</sup>i<sup>3</sup> K<sup>3</sup>i<sup>3</sup>b<sup>3</sup>v<sup>3</sup> č<sup>3</sup>v<sup>3</sup>q<sup>3</sup>b, w<sup>3</sup>m<sup>3</sup>x<sup>3</sup>v<sup>3</sup>š<sup>3</sup>i<sup>3</sup> M<sup>3</sup>ḡ<sup>3</sup>Y, w<sup>3</sup>b<sup>3</sup>č<sup>3</sup> R<sup>3</sup>b<sup>3</sup>v<sup>3</sup>, w<sup>3</sup>b<sup>3</sup>q<sup>3</sup>š<sup>3</sup>Y I m<sup>3</sup>g<sup>3</sup>š<sup>3</sup>q<sup>3</sup> m<sup>3</sup>vab K<sup>3</sup>i<sup>3</sup>č<sup>3</sup>Z n<sup>3</sup>q; e'e-vcbvč<sup>3</sup>K<sup>3</sup>i<sup>3</sup> t<sup>3</sup>Zg<sup>3</sup>v<sup>3</sup>b GB GK<sup>3</sup>B č<sup>3</sup>č<sup>3</sup>u<sup>3</sup>q<sup>3</sup>vq K<sup>3</sup>v<sup>3</sup>R K<sup>3</sup>i<sup>3</sup>č<sup>3</sup>Z n<sup>3</sup>q| č<sup>3</sup>k<sup>3</sup>ymb n<sup>3</sup>j č<sup>3</sup>w<sup>3</sup>i<sup>3</sup> K<sup>3</sup>i<sup>3</sup>b<sup>3</sup>v<sup>3</sup> I w<sup>3</sup>m<sup>3</sup>x<sup>3</sup>v<sup>3</sup>š<sup>3</sup>i<sup>3</sup> M<sup>3</sup>ḡ<sup>3</sup>Y K<sup>3</sup>i<sup>3</sup> w<sup>3</sup>K K<sup>3</sup>i<sup>3</sup>č<sup>3</sup>Z nč<sup>3</sup>e Ges e'e-vcbv n<sup>3</sup>j č<sup>3</sup>w<sup>3</sup>i<sup>3</sup> K<sup>3</sup>i<sup>3</sup>b<sup>3</sup>v<sup>3</sup> I w<sup>3</sup>m<sup>3</sup>x<sup>3</sup>v<sup>3</sup>š<sup>3</sup>i<sup>3</sup> M<sup>3</sup>ḡ<sup>3</sup>Y K<sup>3</sup>i<sup>3</sup> w<sup>3</sup>K<sup>3</sup>f<sup>3</sup>vč<sup>3</sup>e Z<sup>3</sup>v m<sup>3</sup>ú<sup>3</sup>v<sup>3</sup>b ev ev<sup>3</sup>č<sup>3</sup>v<sup>3</sup>q<sup>3</sup>b K<sup>3</sup>i<sup>3</sup>č<sup>3</sup>Z nč<sup>3</sup>e| w<sup>3</sup>q<sup>3</sup>vč<sup>3</sup>q<sup>3</sup>č<sup>3</sup>i<sup>3</sup> Z<sup>3</sup>v<sup>3</sup>B KLbI i<sup>3</sup>ayč<sup>3</sup>k<sup>3</sup>ymb, KLbI i<sup>3</sup>aye'e-vcbv Av<sup>3</sup>e<sup>3</sup>v<sup>3</sup>i KLbI č<sup>3</sup>k<sup>3</sup>ymb I e'e-vcbv GK<sup>3</sup>mč<sup>3</sup>½ e<sup>3</sup>e<sup>3</sup>ü<sup>3</sup>Z n<sup>3</sup>č<sup>3</sup> Av<sup>3</sup>mč<sup>3</sup>Q|

e<sup>3</sup>v<sup>3</sup>s<sup>3</sup>vč<sup>3</sup>t<sup>3</sup>č<sup>3</sup>k<sup>3</sup>i<sup>3</sup> g<sup>3</sup>va<sup>3</sup>w<sup>3</sup>gK w<sup>3</sup>q<sup>3</sup>v<sup>3</sup>i t<sup>3</sup>q<sup>3</sup>č<sup>3</sup>i<sup>3</sup> m<sup>3</sup>č<sup>3</sup>e<sup>3</sup>P<sup>3</sup> b<sup>3</sup>w<sup>3</sup>Z w<sup>3</sup>ba<sup>3</sup>f<sup>3</sup>Yx A<sup>3</sup>½ w<sup>3</sup>nt<sup>3</sup>mč<sup>3</sup>e w<sup>3</sup>q<sup>3</sup>v<sup>3</sup> g<sup>3</sup>š<sup>3</sup>Yj<sup>3</sup> t<sup>3</sup>q<sup>3</sup>i Ae<sup>3</sup>-vb| G<sup>3</sup>i<sup>3</sup>c<sup>3</sup>i č<sup>3</sup>ḡ<sup>3</sup>ḡ<sup>3</sup>μ<sup>3</sup>č<sup>3</sup>g<sup>3</sup> g<sup>3</sup>va<sup>3</sup>w<sup>3</sup>gK I D<sup>3</sup>č<sup>3</sup>P<sup>3</sup>w<sup>3</sup>q<sup>3</sup>v<sup>3</sup> Awa<sup>3</sup>č<sup>3</sup>Bi, Av<sup>3</sup>Ā<sup>3</sup>v<sup>3</sup>j<sup>3</sup> K č<sup>3</sup>w<sup>3</sup>i<sup>3</sup>č<sup>3</sup>Bi, t<sup>3</sup>R<sup>3</sup>j<sup>3</sup>v w<sup>3</sup>q<sup>3</sup>v<sup>3</sup> Av<sup>3</sup>č<sup>3</sup>d<sup>3</sup>m I w<sup>3</sup>q<sup>3</sup>v<sup>3</sup> č<sup>3</sup>č<sup>3</sup>Zō<sup>3</sup>v<sup>3</sup> w<sup>3</sup>ij i<sup>3</sup>č<sup>3</sup>č<sup>3</sup>Q| w<sup>3</sup>q<sup>3</sup>v<sup>3</sup> g<sup>3</sup>š<sup>3</sup>Yj<sup>3</sup>q th b<sup>3</sup>w<sup>3</sup>Z I č<sup>3</sup>w<sup>3</sup>i<sup>3</sup> K<sup>3</sup>i<sup>3</sup>b<sup>3</sup>v<sup>3</sup> M<sup>3</sup>ḡ<sup>3</sup>Y K<sup>3</sup>i<sup>3</sup> w<sup>3</sup>q<sup>3</sup>v<sup>3</sup> Awa<sup>3</sup>č<sup>3</sup>Bi, č<sup>3</sup>w<sup>3</sup>i<sup>3</sup>č<sup>3</sup>Bi, t<sup>3</sup>R<sup>3</sup>j<sup>3</sup>v Av<sup>3</sup>č<sup>3</sup>d<sup>3</sup>m Ges m<sup>3</sup>e<sup>3</sup>f<sup>3</sup>k<sup>3</sup>i avč<sup>3</sup> w<sup>3</sup>q<sup>3</sup>v<sup>3</sup> č<sup>3</sup>č<sup>3</sup>Zō<sup>3</sup>v<sup>3</sup> w<sup>3</sup>ij t<sup>3</sup>m<sup>3</sup>B b<sup>3</sup>w<sup>3</sup>Z I č<sup>3</sup>w<sup>3</sup>i<sup>3</sup> K<sup>3</sup>i<sup>3</sup>b<sup>3</sup>v<sup>3</sup> ev<sup>3</sup>č<sup>3</sup>v<sup>3</sup>q<sup>3</sup>t<sup>3</sup>bi w<sup>3</sup>v<sup>3</sup>q<sup>3</sup>č<sup>3</sup>Z; w<sup>3</sup>b<sup>3</sup>č<sup>3</sup>q<sup>3</sup>w<sup>3</sup>RZ| t<sup>3</sup>m<sup>3</sup>B w<sup>3</sup>K t<sup>3</sup>č<sup>3</sup>K w<sup>3</sup>e<sup>3</sup>č<sup>3</sup>e<sup>3</sup>P<sup>3</sup>v<sup>3</sup> K<sup>3</sup>i<sup>3</sup>č<sup>3</sup>j w<sup>3</sup>q<sup>3</sup>v<sup>3</sup> g<sup>3</sup>š<sup>3</sup>Yj<sup>3</sup> t<sup>3</sup>q<sup>3</sup>i K<sup>3</sup>v<sup>3</sup>Rč<sup>3</sup>K č<sup>3</sup>k<sup>3</sup>vm<sup>3</sup>w<sup>3</sup>K Ges Awa<sup>3</sup>č<sup>3</sup>Bi, č<sup>3</sup>w<sup>3</sup>i<sup>3</sup>č<sup>3</sup>Bi, t<sup>3</sup>R<sup>3</sup>j<sup>3</sup>v w<sup>3</sup>q<sup>3</sup>v<sup>3</sup> Av<sup>3</sup>č<sup>3</sup>d<sup>3</sup>m Ges w<sup>3</sup>e<sup>3</sup>č<sup>3</sup>v<sup>3</sup>q<sup>3</sup> w<sup>3</sup>ij i<sup>3</sup> w<sup>3</sup>v<sup>3</sup>q<sup>3</sup>č<sup>3</sup>K e'e-vcbvi K<sup>3</sup>v<sup>3</sup>R w<sup>3</sup>nt<sup>3</sup>mč<sup>3</sup>e Av<sup>3</sup>L<sup>3</sup>w<sup>3</sup>q<sup>3</sup>Z K<sup>3</sup>iv hvq| w<sup>3</sup>K<sup>3</sup>š<sup>3</sup> GK<sup>3</sup>w<sup>3</sup> w<sup>3</sup>b<sup>3</sup>ḡ<sup>3</sup> w<sup>3</sup>e<sup>3</sup>č<sup>3</sup>v<sup>3</sup>č<sup>3</sup> t<sup>3</sup>q<sup>3</sup>i č<sup>3</sup>āvb hLb Z<sup>3</sup>u<sup>3</sup> w<sup>3</sup>b<sup>3</sup>R w<sup>3</sup>e<sup>3</sup>č<sup>3</sup>v<sup>3</sup>q<sup>3</sup> č<sup>3</sup>w<sup>3</sup>i<sup>3</sup> P<sup>3</sup>v<sup>3</sup>j<sup>3</sup> b<sup>3</sup>v<sup>3</sup>i R<sup>3</sup>b<sup>3</sup> č<sup>3</sup>w<sup>3</sup>i<sup>3</sup> K<sup>3</sup>i<sup>3</sup>b<sup>3</sup>v<sup>3</sup> č<sup>3</sup>v<sup>3</sup>q<sup>3</sup>b I w<sup>3</sup>m<sup>3</sup>x<sup>3</sup>v<sup>3</sup>š<sup>3</sup>i<sup>3</sup> M<sup>3</sup>ḡ<sup>3</sup>Y K<sup>3</sup>i<sup>3</sup>b, ZLb w<sup>3</sup>Z<sup>3</sup>w<sup>3</sup>b č<sup>3</sup>k<sup>3</sup>vm<sup>3</sup>w<sup>3</sup>K

<sup>3</sup> The World Book Encyclopedia, Vol-8, p-73.

`vqZB cvj b Kti \_vtKb| GZŋŋi Avtj vPbv t\_ŋK cŹxqgvb nq th, cŹŌvŋbi D"PZi  
chŋq cŋvmb AwakZi , iazcŸŸ Aciw ŋK, cŹŌvŋbi wbgrechŋq e'e`rcbv AwakZi  
, iazcŸŸ we`'ij ŋqi GKRB wŋŋK hLb avtc avtc cŋ`vbŋZ cŸŌ nŋq cŋvb wŋŋK cŋ`  
AwawŌZ nb, ZLb Zwi cŋvmbK `vq`vqZ; AŋbK teŋo hvq| wKŠ' cwi Kí bv Ges wmxvš  
ev`évtŋbi tŋŋŋ wŋŋKMYB , iazcŸŸŋgKv cvj b Kti \_vtKb|

divmx wíciZ I cŋvmbK tnbŋx tdqj (1841-1925) Zwi MŠ' Administration  
Industrielle et Generale (1916) MŠ' Dŋŋ Kŋŋŋ "Management process  
consists of planning, organisation, command, co-ordination and control."  
e'e`rcbv mŋvš Awakvsk cŋŋK tdqj i G avi Yv Abŋi Y Kiv nŋ"Q| tdqj i gŋZ  
cwi Kí bv, mŋVb, wŋŋ`R, mgšŋ Ges wŋqšŋ e'e`rcbv cŋŋvri AŠMŋ| cŋvmb mŋvš  
Avtj vPbv t\_ŋKI `úóZ cŋvŋYZ nq th, cŋvmbK KgŋvŌI GKB cŋŋvq AvewZŋ|



**cV#VĒi gj`iqb: 1**

**A) eū ubePbx cĕæ**

m#WK DĒi ũb#`Rgj-K Aŋi#U#K eĒv#qZ Kiab| (D`vniY: Avcbvi ũbe#PZ DĒi#U K ntj G#K (K) eĒv#qZ Kiab)

1. ũb#Pi tKvb `e#kó#U cĕv#t#bi tŋ#Ī A#KZi c#hvR`?  
 K. cĕv#b GK#U Kg#y# c#u#q#  
 L. cĕv#b GK#U Drcv`bg#y# c#u#q#  
 M. cĕv#b GK#U e`#3#t#K#`K c#u#q#  
 N. cĕv#b GK#U D#Ī k`g#y# c#u#q#|

2. ũe`#ij q c#i P#j b#i tKvb ch#q cĕv#b A#KZi , i#z#y#?  
 K. D`PZi ch#q  
 L. ũbg#Zi ch#q  
 M. ga` ch#q  
 N. mKj ch#q|

3. e`e`#cb#i gj# ũb#Pi tKvb ũR#b#m#U ũe`#gv#?  
 K. Drcv`b  
 L. k#  
 M. e`#3# ev Personnel  
 N. m#M#b|

**Av) iPb#q#-K cĕæ**

1. Avcbvi ũe`#ij #qi c#i P#j b#i m#m#š#`# b#`b K#h#e#ij mg#ni m#ŋ#B ũe#i Y ũ`b| G mKj K#h#e#ij i tK#b#U cĕv#b Ges tK#b#U e`e`#cb#i m#½ A#KZi m#ú#3#? m#y#ú#f#te ũP#y#Z Kiab|



**m#WK DĒi**

- A) 1| N, 2| K, 3| M|

**cW 2**

**ւկղյւ շկմբ I ԷԷ՛ւՅբւi A\_©msÁv I գյ-ԲՄԶ**

**DՃԻԿ՝**

GB cW ԻԿՃI AւՅԻԲ—

- ւկղյւ շկմբ I ԷԷ՛ւՅբւi msÁv շՕՅb KiՃZ շւիճԵb;
- ւկղյւՃԻԻ ւկղյւ շկմճԵbi AււԷԲԷ մսւճԿԷ՛ւի Yv շՕՅԵ մԳԳ յԵԵb;
- ւկղյւ շկմբ I ԷԷ՛ւՅբւi ԷււՕ՝մգԲ DՃԼԼԷԹ Ab՛ՅԵ՝ շկմճԵbi մճ½ ւկղյւ շկմճԵbi շւ\_Թ՝ ւԵիԳY KiՃZ շւիճԵb Ges
- ւկղյւ շկմճԵbi գյ-ԲՄԶ\_ւյ DՃԼ KiՃZ շւիճԵb|

**ւկղյւ շկմբ I ԷԷ՛ւՅբւi A\_©**

ՇԷԶԹ շւՅՅ շկմբ I ԷԷ՛ւՅբւi մսւճԿԷ՛ւ AւճյւԲբւi ԳՕԳՃZ ւկղյւ շկմբ I ԷԷ՛ւՅբւiԿ մգAճ\_Է՛Ե՛նւi Kiv AւաԿZi հյՅՄՈ՛՛| ÁՅԵbi GKւՍ շւ\_K կՅLՅ ւնճԵ ւկղյւ շկմբ I ԷԷ՛ւՅբւi ւԷKւԿKւյ LԳ ԵււԿ ւճԵi ԲԳ| EԲւԷճ կZՅáxi ԻԿI ւճԿ GKւՍ ԳճմսւՅԳԷԼԳ ւնճԵ ւկղյւ շկմճԵbi AււԷԲԷ NՃUճQ| Է՛Ե՛մւ շկմճԵbi մՅԳ՝ I AMՄՈ՛՛ ւԷճ կZՅáxi ԻԿՃZ հյՅիճՕի ւկղյւԷ՛ճի DrmւնZ Kճi ԻZՅԳ | Zւիւ Է՛Ե՛մւ շկմճԵbi ԻԳՃԻ շՕՅ Z ZԷ; a՛Յb-աւi Yv I ԲՄԶԳյ ՅԿ ւկղյւՃԻԻ շՕԳճM մճՕՕ յԵb|

ւկղյւ շկմբ I ԷԷ՛ւՅբւi ԷյճZ ւկղյւԼՅZ շՕՅ մսւճ՝i մԵԷԳ Է՛Ե՛նճի i մւնճԵ՝ ւկղյւi յԳ՝ I DՃԻԿ՝ ARճԵbi շՕԳճԿ ԵՅՅՅԳ| A\_Թ ւկղյւi յԳ՝ I DՃԻԿ՝ Ե՛ՅՅՅԵԵbi Rb՝ մււԷԹ ԵԵ KւհԷԳ ZՅԿB ւկղյւ շկմբ I ԷԷ՛ւՅբւi ԷյՅ յԳ| ԵԵ ԻԿՅ շՕZՕՅԵbi ԳԷ՝ DՃԻԿ՝ յճՕ շՕZՕՅԵbi մ՝մճ՝i Է՛ւԳZ; I KւհԷՅի i մԳZմԳճճ մՅԵ Kiv հՅZ շՕZՕՅԵbi ZՅi ԲւաZ յճԳ՝ ԳՕՕՅZ շՅԵ| ւկղյւ շՕZՕՅԵbi ԻԳՃԻ GB ԳԷ՝ DՃԻԿ՝ ւԿԼԵ-ԻԿԼՅԵԵ Է՛ՅԵԵԵbi ւնճի AՅՅZԳ| AZԳԷ ւկղյւ շՕZՕՅԵbi ԻԳՃԻ ւկղյւ շկմբ I ԷԷ՛ւՅբւi գյ-ԸԸԻԷ՝ յԳ, ւԿԼԵ-ԻԿԼՅԵԵ Է՛ՅԵԵԵbi ԸԵԵԳ| “The central purpose of administration in any organization is that of coordinating the efforts of people toward the achievement of its goals. In education these goals have to do with teaching and learning. Thus, administration in an educational organization has as its central purpose the enhancement of teaching and learning.”<sup>4</sup>

ւԿԼԵ I ԻԿԼՅԵԵbi KւՅ Z\_Յ շՕZՕՅԵbi ւկղյւi ԸԵԵԳԵbi յճԳ՝ GԿՅ շՕZՕՅ շՕՅԵbi հՅ KիYԳ ZՅ յԳ :

1. շՕZՕՅԵbi Rb՝ յԳ՝ I ԲՄԶ ւԵԵԳ Y Kiv,
2. յԳ՝ I DՃԻԿ՝ ARճԵbi Rb՝ մւՅԿ ԿԳԷ՛ւZ ւԵYԳ,

<sup>4</sup> Introduction to Educational Administration, 5<sup>th</sup> Edition, Roald F. Campbell, Edwin M. Bridges, Raphael O. Nystrand, chapter 4, Page 102.

օ՞ Ae GWՀKkb

3. cwi Kí bv c՛ղqb I ev ՛ըvqb Kվ՚Ri mgš՛ճ mvab Kiv,
4. Aժ\_թ ms ՛vb Kiv Ges
5. Dc՛tivr<sup>3</sup> Kvհթեւյ mսււ՛՛՛bi tղ՛tի c՛՛ՀՕւ՛tbi ՛ղZv I Kvհ՛ււււ Zv gj ՛ւqb Kiv/

tKiv GKRB ւկղւե՛՛՛ i գ՜Z, "The purpose of educational administration is to enable the right pupils to receive right education from the right teachers at a cost within the means of the state, under conditions which will enable the pupils to profit from their training." A\_թ i v՛ղq A\_թու՛ZK mvgժ\_թ gժa՛ Dchթ ւկղ՛tKi Օւււ GKRB Dchթ ւկղւ\_թ Ggb GKււ Ae ՛v ev cwi շե՛k Dchթ ւկղւ MծիY mg\_հե th Ae ՛v ev cwi շե՛k Zii ւկղւ MծիYi Rb՛ մթե՛Էg nթe Ges th ւկղւi gva՛՜g tm Zvi Rxe՛bi մթե՛Էg dj j v f Ki շe|

ւկղւ ճկւմ՛bi gj- DcRիե՛՛՛ gvbly| e՛ւր<sup>3</sup> gvbyl i Dbու՛Zi ga՛՛՛ ւ՛՜ղ mցու՛i Dbու՛Z Z\_v mgMՕ t՛k I Rու՛Zi Dbու՛Z ւկղւ ճկւմ I e՛e ՛ւcbvi j ՛ղ՛՛ ՛ղ ւկղւ ճկւմ I e՛e ՛ւcbv mյթ ւկղւ e՛e ՛ւi mւււի՛ th՛ t՛՜ki Rb՛tMւ՛՛x՛tK Rbkւր<sup>3</sup>՛Z i fcv՛՛՛՛՛ի Z Ki՜Z cիտi, th Rbkւր<sup>3</sup> mei Kg Dըqb Kg՛ւի՛՛՛i ւbզvգK|

G hver Av՛tj vPbvq ՛ւո՛ZB տե՛Sv tMj ւկղւi j ՛ղ՛՛ I D՛իկ՛՛ ev ՛ըv՛tbi Rb՛ մւե՛՛R th Kvհթը Zի՛tKB ւկղւ ճկւմ ev e՛e ՛ւcbv ej v th՜Z cիտi | ւկղւ ճկւմ gj-Z ւե՛՛յ q msMvB, cwi Puj bv I ւb՛՛ Rbvi մժ½ mսււ<sup>3</sup> | Gi D՛իկ՛՛ RvZիq շիթ t\_ժK i iա՛ K՛i gv շիթ շիթ ւկղւi Dըqb, ճիւի I ւե՛Kւկ mvab | ւկղւi gva՛՜g gvby՛tK Zvi mըvե×Zv t\_ժK gւթ t՛ I qv ւկղւ ճկւմ՛bi KւR|

t՛ Lv հvq, Kv՛tj i ճըւտn mgժqi cւիե՛Zթbi avիq Dbւesկ kZvաի tkI ւ՛՜՜K GKււ c\_ւ K kv\_ււււի ւկղւ ճկւմ՛bi Avւե՛իթ| tj v K ճկւմ, e՛emv ճկւմ I ւկի ճկւմ t\_ժK D՛մե՛ ւկղւ ճկւմ՛bi ևե՛կո՛ւււյ՛ tZ G mKj ճկւմ՛bi ւկՕyճիւե ւե՛՛ ճv ՛v Kւ ւեւ՛Pի bq| GZ՛ մժԷլ ւե՛ղ ււււի ւկղւ ճկւմ GKււ ՛Z՛՛; ևե՛կո՛ ևե՛կո՛ ցւ՛Z | ւկղւ ճկւմ՛b j v f ՛ղւ Zi ճկււ tM՛Y | Aci ւ՛՜K e՛emv ev ւկի ճկւմ՛b j v f ՛ղւ Zi ճկււ gԷ՛՛ | ւկղւ ճկւմ՛bi j ՛ղ՛՛ ARՑ mյյ շիւիւ| e՛emv ճկւմ՛bi b՛ւq Zv ՛ղւ YK dj ւե՛Pի ւկղւ ճկւմ՛bi ևա՛Z; Abըւե b մե՛՛ bq|

## ւկղւ ճկւմ I e՛e ՛ւcbvi gj-բու՛Z

th tKiv Kg՛մսււ՛՛՛ bi Rb՛ ւկՕyւbզg Kvտ՛tbi ճըqւRb i՜tժtՕ | mյթւր՛՛՛Z I msւեւե× GB ւbզg Kvby Kցիսււ՛՛՛ b՜K Zիւր՛՛Z K՛i Ges ւ՛ K ւb՛՛ ւկւ ււււի KւR K՛i | ւկղւ ճկւմ I e՛e ՛ւcbvi tղ՛tի tZցււ ւկՕyւbզg ււււ Z i՜tժtՕ | G mKj ւbզg Բու՛Z tK ւկղւ ճկւմ I e՛e ՛ւcbvi gj-բու՛Z ււււի ւե՛թePbv Kiv հvq | GB gj-բու՛Z, ւյ ւկղւ ճկւմ I e՛e ՛ւcbvi Kվ՛R Mւ՛Z ճուբ K՛i Ges ճ՛ՀՕւ՛tbi j ՛ղ՛՛ I D՛իկ՛՛ ARթbi ւbզvգ ււււի KւR K՛i | GKRB ւկղւ ճկւմK ev e՛e ՛ւcbtKi Rb՛ G mKj ւbզg Բու՛Z Rvbv Acւի ւիթ gj-բու՛Zi մււ՛K Abյի Y ճկւմ՛bi KւR tK mnR K՛i Ges msMvB ev ճ՛ՀՕւ՛tի K Bւա՛Z j ժ՛ղ՛i ւ՛՜K ւbժq հvq | ւbժP Gi f c ւկՕy gj-բու՛Z Z՜j aiv nj :

1. cġvmřKi Rb` Rıvr AZ`vek`K th cġvmb GKıU Dřık`gıx cġıqv| mslMVřbi Dřık` ARřbi Rb` mslMb ev cġZövb msıkw m`mř`i `ııqZj| Kg<sup>©</sup>mııw`Ÿ Kiv Ges cġZövrřbi e`MZ Dcv`řřbi cġıB I mřelĒg e`envi ıııwÖZ Kiv cġıvrRb|
2. cġvmb GKıU AZ`vek`Kıq mıgvıRK Ges gıvıek cġıqv| KıřRB cġZövrřbi gıvıy Z\_v `j m`úřK<sup>©</sup>Rıvr cġvmřKi Ab`Zg KıR| gıvıyřK KıřR jııMıřbıvı KıRııUřK mnR Kıvı Rb` gıvıyřK Rıvr Z\_v `řj i gıvıyř i e`ıı<sup>3</sup>Zj; AvııY I Pııı`v m`úřK<sup>©</sup> mRıM ř\_řK cġvmb Kıv<sup>©</sup>ııı Pıj bıv Kıv DĒg|
3. řřřnZzııřııv cġZövb GKıU mıgvıRK BııııUDkb, GLıřb Superordinate-Subordinate Relationship ev EaZb Aa`b m`úřK<sup>©</sup> cġıU ııııRgıv| cġZııU Mııc ev `řj i Kg<sup>©</sup>ev m`mř`i Rb` mıııw`Ÿ Kg<sup>©</sup>ııZ Ges bıııZgıj v\_vKıv evĀıııq|
4. Dchŷ e`ıı<sup>3</sup>řK Dchŷ `ııqZj;cġıvb DĒg e`e`ııcvrı `ııııó|
5. cġZııU Kg<sup>©</sup>ev m`řm`ı Rb` KıřRı h\_vh\_gj` ıııııııı ev ,Y ıııııııı e`e`ıı\_vıKıv cġvıııııı bıııZgıj vı Aııeř`Q` A½|
6. cġZövrřbi mKj m`řm`ı Rb` Kg<sup>©</sup>ZııBı e`e`ıı KıřR Avb` ř`q Ges KıřRı ,ıııZ gıv eıııřZ mıııqZıv Křı |
7. ıııııııı ř\_řK GKıřWııgK `ıııııııı cġıvb ıııııııı gıřbııııııı mıııııııı|
8. cġZövrřbi Rb` Dchŷ I mııııııı ıııııııı ıııııııı Ab`Zg KıR| mřelĒııı ,
9. cġZövrřbi Kg<sup>©</sup>ıııı GKıU mııııııı ıııııııı I e`e`ıı ıııııııı ıııııııı Z nııııı evĀııııııı| GřZ j`ıı` ARŸ mnR nq| "The management must lay down an efficient system for getting the work done."<sup>5</sup>

<sup>5</sup> The World Book Encyclopedia, Vol-8, P-73.



**ci#Vēi gj`iqb: 2**

**A) eū ibePbx cĕæ**

m#WK DĒi ubt`Rgj-K AŋiuU#K eĒv#qZ Kiab| (D`vniY: Avcbri ube#PZ DĒi#U K ntj G#K (K) eĒv#qZ Kiab)

1. ukŋv cĕv#tbi gj- DcRxe` tKvbiU?
  - K. we`ij q
  - L. gvby
  - M. ukŋv#g
  - N. ukŋK|
  
2. ukŋv cĕv#b I e`e`vcbri hveZxq KgRvU tKvbiU#K #N#i AvenZ` nq?
  - K. ukŋv\_#
  - L. ukŋK
  - M. ukLb-tkLv#bv cĕ#qv
  - N. ukLb mvgM#|
  
3. ukŋv cĕv#b I e`e`vcbri gj-b#vZ ej #Z tKvbiU#K tevSvq?
  - K. `b#`b Kvk i#U#b cĕ#qb
  - L. m#P#S#Z I m#v#e#x #bqg Kvbly Abyri Y
  - M. Av#`k ubt`R Rvix
  - N. ci#ŋv M#Y|

**Av) iPbv#j-K cĕæ**

1. we`ij q c#i Pvj bvi tŋ#t ukŋv cĕv#b I e`e`vcbri m#v#s#l th mKj gj-b#vZ Avc#b Abyri Y K#i \_v#Kb, Zvi GK#U m#v#ŋ#B c#i #P#Z c#vb Kiab| GB m#½ gj-b#vZ m#k# th mKj `v#qZ; Ges Kiv#e#j Avc#b cij b K#i b Zvi weei Y # b|



**m#WK DĒi**

- A) 1| L, 2| M, 3| L|

**cW 3**

**ukŋlv cġvmb I e`e`vcbv mspvšġ Kvhŋej**

**Dġġk**

GB cW tkġl Avġvb—

- weifbankŋve` Ges gbxl x KZR.c0Ē ukŋlv cġvmb cġvqv weifbav` K Dġġ KġZ cviġeb;
- ukŋve` ev gbxl x`i c0Ē ukŋlv cġvmb cġvqv mspvšġ Kvhŋej e`vL`v KġZ cviġeb;
- ukŋlv cġvmb mspvšġ Kvhŋej i msvŋB cvi vPvZ c0vb KġZ mŋg nġeb|
- ukŋlv cġvmb mspvšġ Kvhŋej i e`vBx ev cvi mi Dġġ KġZ cviġeb|

**ukŋlv cġvmb I e`e`vcbv mspvšġ Kvhŋej**

e`vck Aġ`Ab`vb` cġvmtbi mġ½ ukŋlv cġvmb mspvšġ Kvhŋej i tZgb tkvb cv`R` tbB| 1916 mġġ tnbix tdqj "Elements of Management" ejġZ th KqW cġvqv K\_v Dġġ KġġQb, tgvUvgvġfvġte cġvmb RMġZ AvRI tm avivB Ae`vnZ iġġQ| tdqj Zui wkġ c0Z0vġbi Avf`AZv t\_ġK th cġvqv, vj i K\_v Dġġ KġġQb, tm, vj nġ`Q cvi Kġbv, msvMb, vb`R, mgšġ Ges vbqšġ (Planning, Organizing, Commanding, Co-ordinating and Controlling) | GB cġvqv, vj ġK vZvb cġvmbK `vqZ; ev KvR vnmġte AvL`vqZ KġġQb| Zui gġZ, "Together these activities constituted the administrative function."

tdqj ġK AbyiY Kġ cieZġZ j\_yvi Mġġ K (Luther Gulick) th dġskb ev KvġRi Dġġ KġġQb tm, vj i Av`vŋi vbġq vZvb `Zui KġġQb POSDCORB| hŋivġof tġmġWġUi `vqZ; m`úġK`vZvb cġvġġġLġQb, "What is the work of the chief executive?0 ZviB DĒġi POSDCORB Gi Avvefġe| POSDCORB e`vL`v Kġġ `vq Planning, Organizing, Staffing, Directing, Co-ordinating, Reporting, Budgeting.

Gi AvU eQi ci mġBgb (Aerbert A. Simon) tdqj Ges Mġġ ġKi KvġRi m`úġviY Kġib Ges Zvġ`i Dġġ mġZ Kvhŋej ġK v`všġMġY KvVġgvi gġa` vetePbvġ cġvm civ| msvMġbi v`všġ MġY cġvqvġ veteġYKġġ tdqj Ges Mġġ ġKi b`vq mġBgb| Planning, Budgeting, Controlling Ges Co-ordinating ġK vetePbvq Avġbb| e`Ztġġ tdqj Ges Mġġ K c0Ē c0ZvU dġskbġKB vZvb v`všġ MġġYi AvL`vq veteġġYi tP0v KġġQb|

cieZġZ vj Pvdġ (Edward H. Litchfield) tdqj, Mġġ K Ges mġBġbi KvġġK AbyiY Kġ cġvmbK cġvqvġ GKvU aviYv `Zui c0P0v tbb| GB cġvqvġK vZvb `vq Pġµ Zġġ aġib| Gġ`i GKvU nj mveġ ev epr Pµ (Administrative Process as a





should see that there is no unnecessary encroachment of their academic rights and personal liberty.”<sup>7</sup>

- **ukŋK Ges ukŋv\_ŋ Dfŋi Rb** mŋzCode of Conduct ev AvPiY uewa \_vKv evĀbxq|
- **ukŋvμŋgi mdj ev`ėvqb GKiu AvZ ,iaZcŸ©cŋvmubK KvR| tkŋYKŋŋi cVb-cvVb cŋμqvi Dci m`v RvMZ `wó tiŋL ue`ij q cĀvb G `vŋqZjU m`úbrKiŋeb|**
- **ukŋvμŋgi mdj ev`ėvqŋbi Rb** GKivŋvŋgK Kvŋŋeij thgb ,iaZcŸ©tZgub mn-cvμŋgK Kvŋŋeij i mdj ev`ėvqbl Acwi nvhŋ
- **ue`ijŋŋi Rb** Aŋ\_ŋ ms`vb Ges ue`ijŋŋi Avq-e`ŋŋi mŋzvmveiŋŋŋi tŋŋĀ ue`ij q cĀvbŋK Aek`B mRvM Ges mZK©\_vKv evĀbxq|
- **ukŋvi e`vŋb thgb e`vcK I wekvj , ukŋv cŋvmb mŋμvŋŋi Kvŋŋeij i e`vŋbl tZgub mŋjŋ ue`Z| GKiu vbw`ŋ vŋqŋgi evvŋŋi I GKRb ukŋv cŋvmKŋK uevfbœAcZ`vŋkZ `vŋqZjcvj b KiŋZ nq|**

Dctiv<sup>3</sup> AvŋjvPvri tčŋŋŋZ ue`ij q cŋvmb I e`ėvcbv mŋμvŋŋi Kvŋŋeij i GKiu mri-msŋŋc cŋvb Kiv thŋZ cvŋi :

- ue`ij q cwi Pvj bv mŋμvŋŋi uevfbœeI q m`úŋK©bŋZ vbaŋŋ Y I cwi Kí bv cŋqb|
- vŋxvŋŋiMŋY I vŋxvŋŋi ev`ėvqbKŋŋi c`ŋŋc MŋY|
- Avŋ\_ŋ e`ėvcbv mŋμvŋŋi `vŋqZjcvj b/Avq-e`ŋŋi vŋvŋe i vLv/cŋŋ m`úŋ`i h\_vh\_e`envi vbwŋZKiY|
- KgŋŋukŋŋK vŋŋqvm I Ziv`i tckvMZ Dbŋŋb mŋŋvM Ges mŋvqZv cŋvb|
- GKivŋvŋgK e`ėvcbv Z\_v ukŋv Kvŋŋeij Dbŋŋb I ev`ėvqŋbi Rb` hveZŋq c`ŋŋc MŋY|
- ukŋv\_ŋ`i Pvv`v ci-Y I Ziv`i tj Lvcovi mŋvqK cwiŋek `Zwi |
- EaŋZb KgŋZŋŋmsŋkŋ`Bi I mŋvŋRi gvŋŋi i mŋ½ thvMŋŋvM I m`úK©`vcb|

eZŋvb cwi evZŋ mŋgŋRK tčŋŋŋŋU GKiv ŋK thgb uevfbœmŋvŋi D<sup>m</sup>e nŋ`Q, tZgub ukŋŋŋŋŋĀ Dŋbŋ NUŋQ be be fveavivi | ue`ij q cĀvbŋi `vŋqZj I KZŋe`i gvŋv e`vcK t\_ŋK e`vcKZi nŋ`Q| G ,ia`vŋqZj cvj bKŋŋi cŋvmubK Avb I `ŋZv Acwi nvhŋ ue`ijŋŋi j ŋŋ I Dŋŋk` ev`ėvqŋbi gvŋŋg t`ŋki mŋveŋ ukŋv e`ėvi j ŋŋ I Dŋŋk` ev`ėvqŋbi tŋŋĀ GKRb cŋZŋvb cĀvbŋi `vŋqZj I KZŋe`i ,iaZj Acwi mŋg| G mZ`vU gŋb tiŋL cŋZv ue`ij q cĀvbŋK `^`^`vŋqZjcvj ŋbi e`vcŋŋi mŋPó nŋZ nŋe|

<sup>7</sup> L.D. Gupta, Educational Administration, Oxford and IBH Publishing Co Pvt Ltd, Delhi, Bombay, Calcutta, P-39.



**cv#Věi gj`vqb: 3**

**A) eû ubePbx cĭœ**

m#WK DĚi ubt`Rgj-K AŃiuU#K eĚvqZ Kiab| (D`vniY: Avcbvi ubePZ DĚiU K ntj G#K **K** eĚvqZ Kiab)

1. cĭvmbK cĭqv tŃtĪ POSDCORB-Gi cĚ<sup>3v</sup> tK?  
K. j yvi MŃj K  
L. tdqj  
M. m#Bgb  
N. vj P#dĭ |
2. cĭvmbK cĭqv tKvb ŃtKI Á P#vK#i Dc`vcb K#i tOb?  
K. j yvi MŃj K  
L. tdqj  
M. m#Bgb  
N. vj P#dĭ

**Av) iPvqj-K cĭœ**

1. ŃkŃv cĭvmb I e`e`vcbr mŃvŃŃ KvhŃvj m#úv`#bi gva`tg ŃKfvte Ńe`vj tqi j Ń` I D#i`k` ev`évb Kiv hŃq? D`vni Ym#K#i vj L#y|



**m#WK DĚi**

A) 1| K, 2| L|

cW 4

we`ij q cwi Pvj bq ukŋv ckvmb I e'e`vcbvi ,iaZj

Dŋik

GB cW tkŋI Avcb—

- we`ij q cŋvbi `vqZj I KZŋe`i cwi na m=utK@Avtj vKcVZ KiŋZ cvi ŋeb Ges
- ukŋv ckvmb I e'e`vcbvi Avb ukŋv GKRb ukŋv ckvmb KŋK w`K ŋbŋ`Rbv cŋv Kŋi Zv wekŋY KiŋZ cvi ŋebj

we`ij q cwi Pvj bq ukŋv ckvmb I e'e`vcbvi ,iaZj Avtj vPbvi cŋvŋ GKRb we`ij q cŋvbi `vqZj I KZŋe`i cwi nai Dci mgvb Avtj vKcVZ Kiv thŋZ cvi | we`ij q cŋvbi `vqZj I KZŋe`i cwi na tKej gvŋ we`ij q cŋvŋ i gŋa`B mgvex bq, we`ij q PZŋi ennŋil Zvi KZŋe`i cwi na we`Zj GB `vqZj I KZŋe`i cwi gŋjŋK ŋbgij ŋLZfvŋe t`Lvŋv thŋZ cvi :

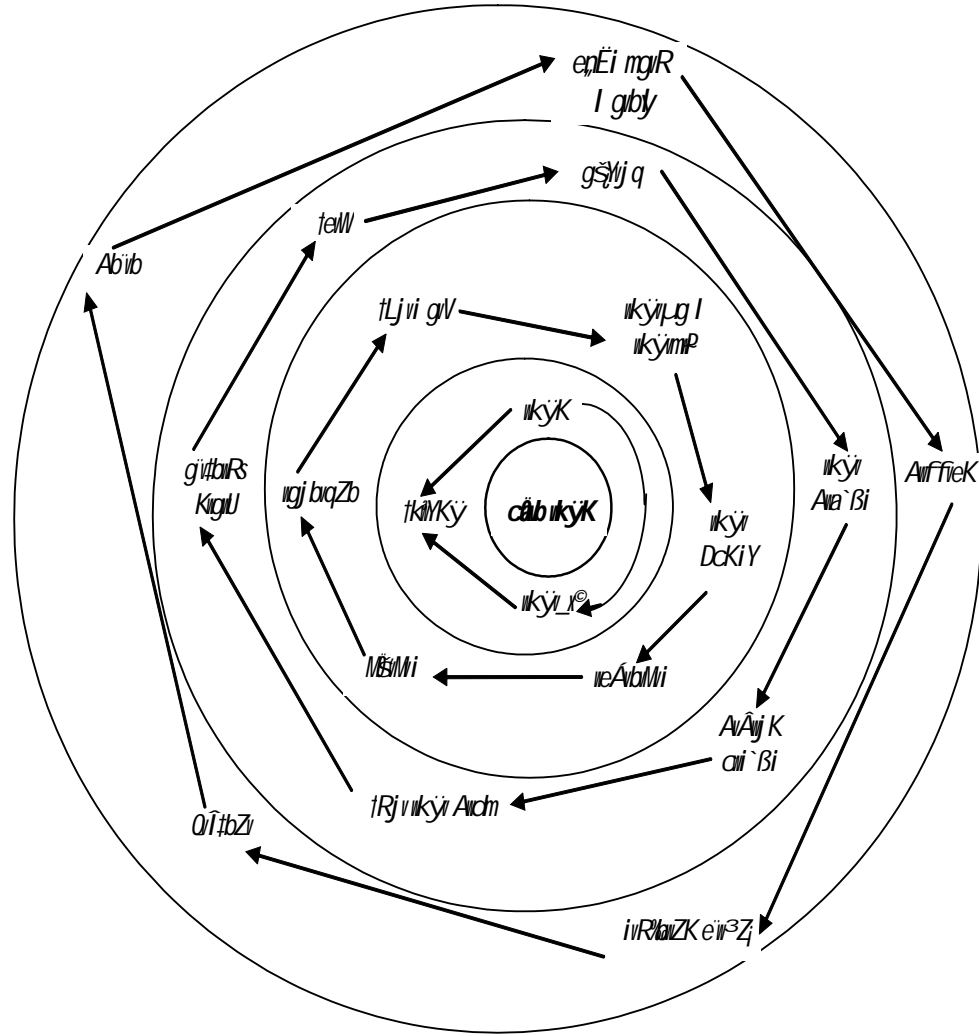

ḡ Ae GW#Kkb

cŃ Ę wPĪ t\_#K GKRb we`ij q cāv#bi `wqZ;I KZ#ē`i cwi wai tgvUvgn# GKwU avi Yv  
civI qv hvq| we`ij q cāv#bi `wqZ;ev Kv#Ri cwi gŪ#j weivwRZ i#qtQ-

- we`ij #qi ewntcwi#ek Z\_v ewn#ii mgvR Ges mgv#Ri m`m`e#`, AwffveK,  
QvĪ#bZv, ivR%b#ZK e`w<sup>3</sup>Z;BZ`w` |
- gšYij q, Aw#`Bi, cwi`Bi, tRj v Awdm, tevW,©g`v#b#Rs KvgwU BZ`w` |
- Af`š#i#Y cwi#ek Z\_v tk#YK#q, wK#qK Ges wK#qv\_#q|
- wK#qv\_#g, wK#qv#m#P, wK#qv DcKiY|
- tfšZ KvV#tgv Z\_v K#j R feb, wqj b#qZb, weÁv#v#Mvi, Mšv#Mvi, tLj vi gvV|
- we`ij #qi Ab`vb` Kg#vi#e#` |

we`ij q cāv#bi cāvb wnmv#te GKRb cāvb wK#qK#K GB cwi gŪj m#ú#K#mRwM\_vK#Z  
n#e| GKRb cāvb wK#q#Ki KvR wK? G cŃk# DEi cŃvb L# mnR bq| we`ij #qi  
cwi`vi cwi`Qb#v I k#Lj v i#qv t\_#K i#æ K#i ewn#ii mgv#Ri m#½ thvM#thvM eRvq  
ivLv I wewfba#Pvc Ges mgm`vi tgvKv#ej v A\_# we`ij #qi w#Zi I ewni GB Dfq w`K  
m#ú#KB Zv#K mRwM I Zrci\_vK#Z nq| cāvb wK#q#Ki me#q#qv , i#z#p#`wqZ; n#`Q  
we`ij #qi GKv#WwqK gvb eRv#qi e`vc#i m`v Zrci\_vKv| wK#q#Ki cv`vb, wK#qv\_#q  
civ M#Y, wK#qv\_#g I wK#qv#m#Pi mdj ev`#vqb, cix#qv M#Y I cwi Pvj bv, Mšv#Mvi Ges  
weÁv#v#M#i i h#\_vch# e`envi w#w#ZKiY, mncv#v#wqK Kvh#ej i mdj ev`#vqb BZ`w`  
cāZwU t#q#ĪB cāvb wK#q#Ki m`v RvM#Z `w#\_vKv evÁb#q| AZGe t`Lv hv#`Q, `wqZ; I  
KZ#ē`i e`vck I wekvj cwi gŪ#j mv\_# I mdj f#te wePiYK#i we`ij q cāv#bi Rb`  
wK#qv cāvmb I e`e`vc#vi Ávb Acwi nvh#

wK#qv cāvmb I e`e`vc#vi Ávb GKRb cāvb wK#qK#K we`ij q cwi Pvj b#q h\_vh\_ w`K  
w#t`Rbv cŃvb Ki#e| wK#qv cāvmb I e`e`vc#vq AwfÁ GKRb we`ij q cāvb w#aj wLZ  
t#qĪ mg#n Zui Ávb I cÁv#K Kv#R j wM#q mdj Kvq n#Z cv#i b t

- K. cwi Kí bv cŃ#qb|
- L. w#x#vš#M#Y|
- M. cŃqvRb#q Ges Ki Y#q Kvh#ej wP#y#ZKiY|
- N. Kvh#ej#qi tk#Y#eb`im|
- O. mgm` m#v<sup>3</sup>KiY I mgv#v# w#Y#q|
- P. we`ij #qi GKv#WwqK gv#bv#q#bi j #q` Kvh#ej M#Y|
- Q. we`ij #qi m#e# gv#bv#q#bi j #q` Kvh#ej M#Y|
- R. Kvh#ej g#`vqb|
- S. g#`vqb cieZ#ē`e`v M#Y|

ukŋv RvZiq Dbq̄tbi ceRZ<sup>⊗</sup> th RmZ hZ teuk ukwŋZ, Zvi Av\_ŋmvgvRK wFZI ZZ gReZ| ukŋvi Dbq̄b ubfP Kti mŷzl ewj ô ukŋv cġvmb I e`e`rcbvi Dci| ukŋvi Dbq̄tbi j tŋ` cġ\_xi Dbz I Dbq̄bkxj t`k\_s,uj ukŋv e`e`rcbvtK weÁvb wFwĒK I MYgubŷi Kj`vYwFwĒK Kivi j tŋ` Avšhi Kfvte mŷPó| Avgvt`i we`ij q\_s,uj i cġvmb I e`e`rcbvi gj-j ŋ` nte ukŋv\_ŋ, ukŋK, ukŋv cġZôvb Z\_v t`tki mmeR ukŋv e`e`ri Dbq̄b mvab|

t`tki ukŋv e`e`ri gvV chŋq Avgvt`i we`ij q\_s,uj i Ae`vb| GB cġvmb I e`e`rcbvi mteP chŋq itqtQ ukŋv gšYj q Ges Gici chŋqμŋKfvte itqtQ Aw`Bi, cwi`Bi, tRjv Awdm BZ`w | ukŋv gšYj q t`tk i iæ Kti we`ij q chŋq chš cġZw tŋtĒB mŷwi Pvj bvi Rb` wv` ŋ AvBb Kvbly I ubqgbwZ itqtQ| G mKj AvBb Kvbly I ubqg bwiZi h\_vh\_ AbyiY, mdj cġqvM Ges ev`evqtbi gta` weÁvb wFwĒK e`e`rcbvi wFZ wbinZ|



**cġVwĒi gj`vqb: 4**

**A) eú ubePbx cġæ**

mŷWK DĒi ubt`Rgj-K AŋiUŷK eĒvŋqZ Kiab| (D`vniY: Avcbvi ubePZ DĒiU K ntj GtK  eĒvŋqZ Kiab)

1. we`ij tqi ewtciwitek ej tZ tKvb aitbi cwi tek tK teiSvq?
  - K. we`ij tqi AwZ ubKtUi cwi tek
  - L. we`ij tqi Pvi t`qvtj i ewntii cwi tek
  - M. tkwYKtŋi ewntii cwi tek
  - N. we`ij tqi tLjvi gvV|
  
2. we`ij q cġvtbi meŋcŋv\_s iæZcY<sup>⊗</sup> vŋqZ; tKvbwU?
  - K. QvTukŋK mŷúKŋRvi`vi Kiv
  - L. cġZôvtbi e`MZ mŷú`i e`envi wvŋZKiY
  - M. we`ij tqi GKvŷwŋgK gv b eRvq ivLvi e`vcvti mŷPó\_vKv
  - N. ukŋKt`i mŷ½ mŷŷúKŋRvq ivLv|

**Av) iPbvgj-K cġæ**

1. we`ij q cwi Pvj bvq ukŋv cġvmb I e`e`rcbvi\_s iæZ; e`vL`v Kiab| ukŋv cġvmb I e`e`rcbvi Ávb ukfvte GKRB we`ij q cġvtK mrvh` Ki tZ cvti?



**mŷWK DĒi**

- A) 1| L, 2| M|

## fygKv

we`ij q mgvŋRi B A½ | mgvŋRi Ab`vb` A½ ev mSMVtbi Zj bviq we`ij q mæZ meŋPtq  
 teik RiUj cwi teŋk cwi Pvi Z nq | we`ij tqi KgŋvŪ cwi Pvi bvi Rb` gube mæú` I  
 e-MZ mæúŋ` i GK RiUj mgšŋqi cŋqvRb nq Ges Ab` th tKvb AvbŋmbK cŋZŋvŋbi  
 gZB Gmŋei Kivŋvŋgv ueb`im, e'e-vcbv I ubŋ`Rbv mæúŋKŋ KivR mæúŋ` b KiŋZ nq |  
 we`ij tqi gj-j ŋ` nj gvbemæú` mŋŋ Kiv | Gw`K t\_ŋK we`ij q mgvŋRi Ab`vb` msMVb  
 t\_ŋK `Zš;`enkö`gŋŪZ Ges Gi cġvmbK I e'e-vcbv mæúŋKŋ mgm`vej I wfbæŋŋ  
 KviY we`ij tqi j ŋ`, Dŋŋk` I mŋeŋ KgŋvŋŪi e'e-vcbvi mŋŋ` mgvŋRi mKj  
 RbmŋaviY RiŋZ | ikŋK, AwffveK, ivRbmZwe` Ges mKj tkŋvi kŋ I tckvRme  
 gvbŋŋ i Avkv Avkv-Lv I `ŋŋ\_P cŋZdj b Nŋŋtq we`ij q cwi Pvi bvi KiŋZ nq | GRb`  
 ikŋv cġvmbK, ikŋK, MŋeIK cŋŋv mKŋjiB cġvmb e'e-vcbvi wefwbæZĒj I aviYv  
 mæúŋKŋ qmKenvj \_vkv cŋqvRb | wefwbæZĒj mgšŋ I mŋŋkŋY wbfŋ aviYvi AvŋŋvŋK  
 Zuiv we`ij tqi A\_ŋŋZK, ivRŋŋZK, mvgvŋRK I gŋvŋeAvbK wbvqKmgŋ chŋŋ vPbv  
 Kiŋeb Ges mŋ\_R I MŋZkŋj cġvmb e'e-vcbvi `ŋŋ\_Gme wbvqK A\_eYŋŋte mSMVZ  
 KiŋZ mŋŋg nŋeb |

msMVb I e'e-vcbv mæúŋKŋ DbZ` t`kmgŋŋ cŋŋ cŋŋqmmK MŋeYv I tj LvŋŋL nŋŋŋQ |  
 Gme MŋeYv I wbeŋŋi aviYvMZ wfwŋ cŋvbZ wZbvŋ ZvŋĒK gj-aviYvi tKvb bvi tKvb  
 GKŋŋi Mŋŋŋi tŋŋ\_Z iŋŋŋQ | Gme ZvŋĒK gj-aviYvŋK e'e-vcbv mŋŋŋZ` (K) wPivqZ  
 msMVb ZĒj (Classical Organisation Theory), (L) mvgvŋRK msMVb ZĒj (Social  
 System Theory) Ges Dŋŋŋ msMVb ZĒj (Open System Theory) wŋŋŋŋ AwfŋŋZ Kiv  
 nŋŋŋQ | KLb KLb Gŋŋŋŋ School of Thought ev Tradition wŋŋŋŋ AwfŋŋZ Kiv  
 nŋŋŋQ | gj-Z Gme ZĒj tKvb msMVb wKfŋŋe KivR Kŋi ev wKfŋŋe KivR Kiv DŋŋZ ŋm  
 mæúŋKŋ e`vL`v cŋvb Kiv nŋŋŋQ | AŋbK mgvŋŋvPK ZĒjŋŋŋ Holistic eŋŋ weŋePbv  
 Kŋiŋŋb | KviY Gŋŋŋŋ e`vcK we`Z. `ŋŋŋŋŋ i e`vL`v cŋvb Kŋi Ges mŋSMVbK  
 Nŋŋvej i ŋgweb`ŋŋm HKmŋ I Aŋŋŋŋŋ thŋŋŋKZv cŋkŋ Kŋi | e`w³ ci`ŋŋi cŋZ  
 tKb AvKó.nq Ges GKmŋŋ`\_ŋŋK, wKfŋŋe e`w³ `úŋ ev A`úŋ j ŋ` ARŋbi Rb` Kg ev  
 teik thŋ` cŋŋŋŋ wŋŋŋŋŋ nq Gme mæúŋKŋ ZĒjŋŋŋ Aek` wfbæwfbæ Abŋŋv ev  
 Assumption Gi Dci cŋZwŋZ | GB BDŋŋŋŋ ZĒjŋŋŋ mæúŋKŋ wŋŋŋŋŋ wZbvŋ cŋv  
 Dc`vcb Kiv nŋŋŋQ |

cŋv- 1: wPivqZ msMVb ZĒj  
 cŋv- 2: mvgvŋRK msMVb ZĒj  
 cŋv- 3: Dŋŋŋŋŋ wŋŋŋŋŋ ZĒj





ᶓPivqZ ZĒj Ges ᶓeÁvbwfivĒK e'e-vcbv cxwZ 1930 Gi `kK chśl necjy RbucqZv ARᶓ KitZ mᶓg ntqij | cieZKvtj mekpvcx Awl R gv'i Kvity Ges klgK e'e-vcK ubieᶓkʃl mKtji gʃa MYZwšK `kᶓbi cĀZ `p Av-iv mᶓoi Kvity ᶓPivqZ ZĒji cĀZ AvKlᶓ nwm tctZ \_vtK | G mgʃB tek wKQy, iazcᶓMᶓelYv, mekl Kti Hawthorne MᶓelYv, Ggb wKQydjvdj ZĒj aʃi hv gvbweK mᶓúKᶓbᶓfᶓ MYZwšK cĀymb I e'e-vcbv ZĒji mPbv Kti Ges e'e-vcbvi tᶓtĀ bZb GKwU avivi mᶓthvRb Kti | Zte Gi dtj ᶓPivqZ ZĒji Av`kMZ J¾j` nwm tctj I Gi cfve mᶓsMᶓvbK KvVtgv I Kvheᶓvjx ᶓbaᶓᶓY A`veᶓa AUᶓ itqʃQ | D`vniY-tᶓc Dᶓjᶓ Kiv hvq th, GLb hᶓ KvDᶓK tKvb cĀZōvb wKfvtē mᶓMᶓVZ Kiv ntqʃQ Ges wKfvtē Zv cwi Pij bv Kiv ntʃQ GB cĀmRᶓÁm Kiv nq, Zvntj Zvi KvQ t\_ᶓK GKwU AvbᶓᶓvbK cĀZōvᶓbi Daᶓb-Aa`b ᶓgᶓvbᶓvq c`web`vm, Kvᶓcwiᶓa, KZᶓj.k;Lj BZ`wᶓ ᶓPivqZ ZĒji kāveᶓj i K\_vB tkvbv hvte |

**ᶓPivqZ mᶓMᶓb ZĒji cĀqm**

eZᶓvb mgʃq wKᶓv cĀymb I e'e-vcbvi tᶓtĀ ᶓPivqZ ZĒji cĀqm KZUKz, iazcᶓᶓZv ᶓúo Kivi ᶓbᶓᶓᶓ ᶓᶓP wKQyZᶓbvᶓj-K Z\_`vej Dc`vcv Kiv nj :

**ᶓPivqZ mᶓMᶓb                      wKᶓv cĀymb I e'e-vcbvi tᶓtĀ cĀqm**

- |   |  |
|---|--|
| <p>1. cᶓ`i ᶓtgv`P web`vm (Hierarchy) Ges KZᶓj `li wfvM  </p> <p>2. KvᶓRi ᶓeÁvbwfivĒK cwi gvc Ges mvdj` gvĀv ᶓbaᶓᶓY  </p> <p>3. Dᶓtᶓk`i HK` (e'e-vcK I Kgᶓ`i)</p> <p>4. ᶓeÁvbK bᶓwZmᶓZ KvᶓRi chᶓᶓᶓ ᶓ-ᶓKiY  </p> <p>5. KvᶓRi tkYwfvMKiY  </p> <p>6. hᶓ_vch<sup>3</sup> ᶓbᶓᶓY tᶓtĀ ᶓbᶓᶓY  </p> | <p>1. QvᶓI Dci wKᶓᶓKi KZᶓj I ᶓbᶓᶓY Ges chᶓᶓᶓ wKᶓᶓKi Dcᶓi mnKvix cĀvb wKᶓᶓKi Ges mnKvix cĀvb wKᶓᶓKi Dci cĀvb wKᶓᶓKi KZᶓj I ᶓbᶓᶓY  </p> <p>2. wlvqvᶓĒK QvᶓI KwZZj; cᶓYZv BZ`wᶓ cwi gvc Ges wKLB gvĀv Abᶓᶓᶓ ᶓj wfvRb  </p> <p>3. wKᶓᶓK, cĀvb wKᶓᶓK, ZĒjeavqK, cĀvmK mKtji b Dᶓtᶓk` GK I Awfbᶓ Qvᶓt`i Rb` hv Kj `vYKi ZvB Kiv  </p> <p>4. ZZxq tkwYi wKᶓv_ᶓ`i Ávᶓbi cwi mᶓgv ᶓbaᶓᶓY Ges GuUᶓK PZz<sup>ᶓ</sup> tkwYi wfvĒ ᶓntmᶓe wetePbvKiY   Abjᶓc PZz<sup>ᶓ</sup> tkwYi Ávᶓbi cwi mᶓgvᶓK cĀg tkwYi wfvĒ ᶓntmᶓe wetePbvKiY BZ`wᶓ  </p> <p>5. BwZvᶓmi wKᶓᶓK, BᶓtᶓRi wKᶓᶓK, ZĒjeavqK, Awdm mnKvix, BZ`wᶓ KZR ᶓwfbᶓwfbᶓKvhᶓmᶓv`b  </p> <p>6. cĀZ wKᶓᶓKi Rb` wĀk Rb cĀᶓᶓK ᶓ-ᶓi wKᶓv_ᶓ, cĀZ wKᶓᶓKi Rb` wĀkRb gvāᶓᶓK ᶓ-ᶓi wKᶓv_ᶓ, cĀZ cĀvb wKᶓᶓKi Rb` `ᶓ Rb mnKvix cĀvb wKᶓᶓK, BZ`wᶓ  </p> |
|---|--|

- 7. KZŕj; k•Lj (Chain of 7. cãvb ukŕŕŕKi ubKU hvlqvi cte©  
Command) gvb`Ki Y| ukŕŕKiv Aek`B mnKvix cãvb  
ukŕŕŕKi mvt\_ K\_v ej te|
- 8. AvPiY wewa cŕŕqb| 8. ukŕŕŕKi n`vUeŕŕ: ŐmKj ukŕŕK  
mKvj 8:00 Uvi gta` -ŕŕj Avmteb  
Ges weKvj 3:30 Uv chŕŕŕ -ŕŕj  
\_vKteb| Kvk iiaKivi cte©Qvŕŕŕi  
Assembly tZ mKj ukŕŕŕK Dcw`Z  
\_vKteb...|Ő
- 9. Kgŕŕ`i gta` k•Lj v cŕŕZŕvKi Y| 9. Qvŕŕiv -ŕŕj i ubqg bmvZ Ges  
m`vPiŕŕYi Av`k© tgteb Pj te|  
ukŕŕŕKMY tckvi Av`k©mgŕŕŕZ ivLteb  
Ges ukŕŕŕv Avw`Bŕii ubt`R tgteb  
Pj teb|
- 10. Kvi Mix Ávb I `ŕŕZvi wŕŕŕŕŕŕZ 10. ubtqŕŕMi Rb` weGW/GgGW  
ubtqŕŕM cŕŕvb| Ges/A\_ev ukŕŕŕK wŕŕŕŕŕŕ AwfÁZv  
\_vKŕŕZ nte|
- 11. KvR m`úv`ŕbi Rb` GKwU mteŕŕŕŕg 11. MwYZ, weÁvb, BwZnvm BZ`w`  
Dciq ubaŕŕŕ Y| ukŕŕŕŕv`ŕbi Rb` mteŕŕŕŕg c×wZ ev  
Dciq ubaŕŕŕYi j ŕŕŕŕ` ubi ew`QbaMteŕŕ Yv  
cwi Pjŕj bvKi Y|



**cv#VvEi gj`vqb: 1**

**A) eú ubePbx c#æ**

m#WK DËi ub#`Rgj-K A¶i#U#K eËv#qZ Kiab | (D`vniY: Avcbri ube#PZ DËi#U K ntj G#K  $\textcircled{K}$  eËv#qZ Kiab)

- 1. #PivqZ Zv#ËKM#Yi #bKU tKvb #elqu# #bQK AcPq etj g#b ntq#Qj ?  
 K. c#h#y#i `#Z c#h#i  
 L. e`e`vcbv c#x#Zi A`¶#Zv  
 M. e`e`vcbv i#x#Zi m#\_ c#h#y#i msN#Z  
 N. Drcv`b tK#`#`#j vi mgm`vej x |
  
- 2. #PivqZ Zv#ËKM#Yi g#Z msMV#b Kg#È#vn m#ó Ges m#e#P `¶#Zv AR# KLb m#e n#e?  
 K. #e#klÁ #b#q#Mi gva`tg  
 L. Kg#È`i `j #efv#Mi gva`tg  
 M. #e#e#e#arv c#r#q#b#i gva`tg  
 N. h#y# m#s#Z K#v#t#v# I K#v#È#x#Zi gva`tg |
  
- 3. ¶#g#Zv tK#\_v#q b`-IKi#Z n#e?  
 K. #e#klÁ Kg#È Dci  
 L. `¶ Kg#È Dci  
 M. KZ#j#k#L#t#j i k#l#e#`i Dci  
 N. Kg#È`i `j #efv#M#\_#t#j#vi Dci |

**Av) ms#¶#B DËi c#æ**

- 1. tKvb t#c#¶#v#c#U #PivqZ Zv#ËKMY Z#`i `#ó#f#Z Z#j a#i#b?
- 2. #PivqZ msMV#b ZË#K meR#b#b `eÁ#v#K ZË#i#n#t#e Av#f#v#Z Kivi `c#t#¶ h#y# K#?
- 3. #PivqZ ZË#A#b#v#i `¶#Zv e#x#i Rb` #K #K Kiv c#q#v#Rb?
- 4. #PivqZ Z#Ë#i Av#K#I ¶ tK#b n#m c#q#?



**m#WK DËi**

A) 1 | L, 2 | N, 3 | M |

cW 2

### miguRK msMVb ZĖj

#### Dt`ik`

GB cW tk`l Av`cb—

- miguRK msMVb ZĖj D`m`ei cUf`ig Dt`j l Ki`z cvi`teb;
- miguRK msMVb ZĖj `enkó` , t`j v eY`b Ki`z cvi`teb;
- ve`'ij tq miguRK msMVb mKf`ite K`vR K`i Z`v eY`b Ki`z cvi`teb Ges
- miguRK msMVb ZĖj I mPivqZ msMVb ZĖj gta` cv`r` m`bifcY Ki`z cvi`teb|

#### f`igKv

mPivqZ msMVb ZĖj; k`igK ev K`g`K m`bQK GK`w e`i Z`j` gtb Kiv nq, Av`j v Z`m`SK h`ts`j tm GK`w Ask gv`l | G ZĖj; k`igKt`i e`m`Z; `Z`y I Av`teM Ab`v`Z`TK D`tc`v`v Kiv nq Ges k`g`vef`vRb, ve`tkl`vqY I K`Z`Z; k;L`t`j i m`f`wĖt`Z Dr`cv``t`bi t`v`t`m`te m`teP`P `v`v`Z`v AR`b`i D`ci , i`az`j Av`tivc Kiv nq| G m`K`j m`v`i K`v`t`YB e`e`v`cbvri t`v`t`m`te Av`P`i`w`YK ve`Av`t`bi m`f`wĖt`Z gvbe m`u`t`K`P m`el`q`w ve`teP`bri K`\_v A`t`b`t`Ki gtb D`w` Z`nq| Elton Mayo I Z`u` m`n`K`g`M`Y K`Z`R. 1920 Gi `k`t`K c`wi`P`m`j Z`n`\_Y`m`g`v`v` (Hawthorne Studies) G`t`v`t`m`te AM`v`x f`v`g`Kv cv`j b K`i |

n`\_Y`m`g`v`v`vq c`g`v`mbZ nq th Dr`cv``t`bi t`v`t`m`te k`igKt`i t`c`v`Yv m`v`b`i Rb` g`R`j`x Ges K`v`R`i k`Z`v`j`x G`K`g`v`l g`E` m`b`q`v`g`K b`q| k`igKt`i m`b`K`U G`m`e , i`az`c`Y`v`e`te`m`P`Z n`t`j I G`t`i `v`b m`Z`x`q`v`t`b| , i`az`c`Y`v`e`l`q m`n`t`m`te c`v`g`v`t`b i`t`q`v`Q m`v`g`m`RK m`u`t`K`P m`el`q`w h`v`t`K Mayo-Gi K`\_v`q ejv h`v`q "A method of living in a social relationship". k`igKt`i `t`j i A`f``s`t`i ve`iv`R`gvb m`v`g`m`RK-g`t`b`v`v`e`Av`m`b`K D`c`v`v`b`m`g`R Dr`cv``b c`v`v`q`v`t`K c`f`Z c`w`i`g`v`t`Y m`b`q`v`j`y K`i, GB , i`az`c`Y`v`e`A`m`e`v`i m`PivqZ e`e`v`cbv ZĖj A`t`b`K t`g`v`j`j K a`v`b av`i Y`v`t`K P`z`g`vi K`i t`q Ges GK`w b`Z`b msMVb ZĖj m`f`c`v`Z K`i | c`k`v`mb I e`e`v`cbvri m`m`n`t`Z` GB b`Z`b m`P`š`t`av`iv`t`K m`v`g`m`RK msMVb ZĖj (Social Systems Theory) et`j A`w`f`in`Z Kiv nq| KL`t`bv KL`t`bv G ZĖj`K g`v`b`e`K m`u`t`K`P`ZĖj (Human Relations Theory) et`j I A`w`f`in`Z Kiv nq|

#### miguRK msMVb ZĖj `enkó`

miguRK msMVb ZĖj; k`igK ev K`g`K `i`K msMVt`bi m`v`t`\_ GK`v`Z`Z`v tev`ta D`v`y Kivi Dci , i`az`j Av`tivc Kiv nq| GL`v`tb k`ig`K`iv m`b`R`t`i msMVt`bi Ask m`n`t`m`te gtb K`i Ges msMVt`bi j`v`v` AR`b` m`b`R`t`i Ae`v`b iv`L`t`Z Me`feva K`i | G`R`b` msMVt`bi Dt`ik`v`e`v`j Aek`B G`gb n`t`q `v`t`K th e`e`v`cbvri m`v`Z c`k`w`Z`i Dci k`igKt`i c`Y`Av`v`i m`v`b` nq Ges Z`v`t`i g`ta` G`gb nek`j`m R`v`M`Z nq th Dt`ik` , t`j vi Rb` K`v`R K`i Z`v`t`i c`v`Z`t`KB m`v`j`j c`v`te I m`š`v`j`v`f` Ki`z cvi`te| g`v`b`e`K m`u`t`K`P Dci c`v`Z`v`b`Z GB g`Z`ev` th `v`f`w`v`t`K

DtaZtj ati Zv nj GB th, mtePP cwi ZB.msmVbB nj metPtq ḡ msmVb| msmVtbi AbivgmbK ḡ j ev Dcḡ j,tjvtK ḡ gb ev webó bv Kti G,tjvi tgšij K Pwinḡ ,tjvi ḡKwZ.† lqv nq Ges msmVtbi Dtiḡkḡi mtḡ G,tjvi mvgAmḡ mvab Kiv nq| GKvR Kivi Rbḡ gvbweK mḡúKḡKvhḡtḡ ḡ mḡvi fivBRviMYtK ḡvqZi cḡvb Kiv nq| gvbweK mḡúKḡZtḡi mḡ "Qv l mḡthvMZvi wfvḡtZ eḡeḡvcK l kḡgKḡi gḡaḡ ḡḡ ev tfḡvtfḡ ubimḡbi Rbḡ eḡeḡvcbvi tḡḡtḡ MYZvḡšK i xvZbvḡZ Abḡxj b Ges kḡgKḡi AskMḡtY Kgḡcwiḡtek mḡḡ l Dḡgḡ thvMḡthvM cḡZḡvKiḡYi Dci wḡtKl tRvi cḡvb Kiv nq|

### weḡ vj q l mvgwRK msmVb

Abḡ th tKvb msmVtbi gZB weḡ vj tq l AMwYZ mvgwRK wḡtḡḡgi AwḡZi i tqḡQ| Gme wḡtḡḡgi tKvb tKvbU AbivgmbK thgb weAvb wḡḡKḡi Kve, Avevi tKvb tKvbU AbivgmbK thgb Pv cvḡbi Avḡv-Pḡ| G,tjv ḡfḡvqx ntZ cvḡi, Avevi ḡxḡvqx ntZ cvḡi | mvgwRK wḡtḡḡg,tjvtK KZK,tjv mvgwRK-gḡbvḡAvbK Dcvḡvb thgb wḡkḡm, Acti i wḡKU cḡḡvkv, tḡḡYv, gḡbvḡve BZḡwḡ AUḡ eḡḡb Aveḡ i vḡL|

mvgwRK wḡtḡḡgi AwḡZi Rbḡ Kgcḡḡ ḡḡ ev ZtZvḡK eḡwḡi cḡqvRb nq hvḡi gḡaḡ wḡwḡḡv NḡU Ges hvḡi tḡvUvḡḡ GKB i Kg j ḡḡ l AvPiwYK aviv ḡvḡK| mvgwRK wḡtḡḡgi cḡvb ḡwḡó,tjv nj : (1) eḡZi, (2) wḡwḡḡv, (3) j ḡḡ, (4) AvPiwYK aviv l cḡvUvbḡGes (5) mgq ev tgqvḡ Kvj | Gme ḡwḡó wḡḡPbv Kti tKvb evmḡvḡvḡ evḡmi Rbḡ Aḡcḡḡgib 8 Rb eḡwḡtK GKUḡ mvgwRK wḡtḡḡg etj AwḡvḡZ Kiv hvḡe Kx? GiUḡK AekḡB mvgwRK wḡtḡḡg ejv hvḡe bv, KviY Gḡi gḡaḡ tKvb wḡwḡḡv nqvḡ Ges Gḡi GKḡ Aeḡvb l tKvb tgqvḡx NUbv bq| Zviv wḡQK KḡgKRb eḡwḡi GKUḡ mgvḡek gvḡ hviv tKvb GKK j ḡḡi tḡḡḡZ Aveḡ bq| Gḡvbḡvḡe 10 Rb Qvḡ hviv cḡḡ wḡ b evḡm Kti ḡḡ hvḡḡQ Zviv l tKvb mvgwRK wḡtḡḡg Mḡo tZvḡ bv| wḡKḡ KḡgKevi GKḡḡ evḡm hvḡvi ci Zvḡi gḡaḡ eḡḡZi bvbv aviv Mḡo DVḡe Ges GKmgq ḡvḡvZB Zviv mvgwRK wḡtḡḡgi eḡḡb Aveḡ ntq hvḡe|

weḡ vj tq AmsLḡ mvgwRK wḡtḡḡg ḡvKḡZ cvḡi GKḡ AvḡMB ejv ntqḡQ| weḡ vj tqi mvgwRK wḡtḡḡgḡK Ggb GKUḡ Dc-wḡtḡḡg (Sub System) wḡtḡḡe wḡḡPbv Kiv thḡZ cvḡi hv Abḡ Avi GKUḡ Dc-wḡtḡḡgi Ask Ges H epḡEi Dc-wḡtḡḡgUḡ Avevi Zḡcḡḡv Avi l epḡEi GKUḡ Dc-wḡtḡḡgi Ask| DḡvniY wḡtḡḡe ejv hvq, ḡḡi ḡḡRb evsjv wḡḡK GKUḡ Dc-wḡtḡḡg Mḡo ZḡtZ cvḡi hv nḡe fvlv wḡḡKḡi Dc-wḡtḡḡgi GKUḡ Ask, hv nḡe gvbweK wḡfivM Dc-wḡtḡḡgi GKUḡ Ask hv nḡe ḡḡi Dc-wḡtḡḡgi GKUḡ Ask, hv nḡe AvḡBḡi Dc-wḡtḡḡgi GKUḡ Ask| GB Dc-wḡtḡḡg,tjvi th tKvb GKUḡi KḡRi aviv ev cḡKwZ. eḡḡZ ntj GiUḡ AvḡMi l cḡi Dc-wḡtḡḡg mḡúKḡP eḡḡZ nḡe| DḡvniYḡḡc DḡP gvaḡḡK ḡḡi BwZvḡm wḡfvḡMi NUbvḡj eḡḡZ ntj weḡ vj q KZRḡ.H wḡfvḡMi Dci AvḡwḡZ wḡvḡbḡla l Pwinḡ Aḡev wḡḡKḡi wḡfvḡḡḡḡḡ Pwinḡ l cḡḡvkv tKgb Zv AekḡB tevSv ḡiKvi| weḡ vj tqi cḡvḡKMY AḡbK mgq wḡḡKḡi tKvb tKvb KvRḡK AvḡḡKmjḡf KvR etj gḡb Kḡib| wḡḡKivi KLḡbv KLḡbv Qvḡḡi AḡḡḡḡK l kḡLjv cwi cḡK AvPiḡYi Kḡv Dḡḡ Kḡib| wḡKḡ msmVbḡK GKUḡ wḡfvḡcḡḡZ ntZ Aetj vKb Kiḡj Gme AvPiY nqZ hḡó thḡḡḡK, kḡLjvcḡḡGes wḡḡKḡi tejvq

Aek`B uk`Kmjyf etj cZxqgvb nte| GLvfb cv`R` nj GB Kvi`Y th e`wZμgag® AvPiY,tjvi gj i`tqQ tKvb GKwU mvgwRK wmt`÷g, c`jiv msMVbuU bq| we`'vtqi weifbaDrm n`Z th me bvbv ai`bi mvsMvubK kw³i D`e nq tm,tjv mwVKfite Dcj`ä Ki`Z bv cvitj c`kvm`b nZvkvi mwó nq hv f`j mgm`vi t`j`i f`j mgvavb etq Avb`Z cvti |

**ivivqZ ZÉj I mvgwRK ZtÉj gta` cv`R`**

ivivqZ msMVb ZÉj I mvgwRK msMVb ZtÉj gta` A`bK w`l`q tg`ij K avi YvMZ cv`R` i`tqQ| w`b`P Gme cv`R`i KtqKwU w`K Dc`vcb Kiv nj :

**ivivqZ ZÉj**

**mvgwRK ZÉj**

1. Aa`b t`\_tK DaZb c`μtg KZé` I `vqZj cvij Z nq|
2. `jgZv c`avb KgRZP ev w`b`f`xi w`bKU t`Kw`fZ`\_v`K|
3. Avb`gmbK j`j`\_v`K hv t`\_tK w`fba Kv`Ri w`b`Rbv Av`m|
4. thw`v`thvM c`Zw`Z gva`g AbyiY Kti Ptj |
5. c`Z`v`bi w`bqgKvby Øviv Drcv`b e`e`v (w`Lb-tkLv`bv Kvh`g) w`bq`šZ nq|
6. DaY`Zbiv Aa`b`i Pw`j`q`tbq|
7. ØØ ev msNvZ AKvh`Ri hv w`bj Kiv c`QvRb etj g`tb Kiv nq|
8. Avw`R Pw`v`v Aa`b`i gta` t`c`Yv mwó Kti |
9. gvby `fveZ KvR Ki`Z Prq bv, mZivs w`bweo cwi`kØ (Supervision) Ri`ix|
10. c`QvRbxq `jZv I `bcY`\_vKtj GKRBtK AvtiKRtbi `v`b Kv`R w`b`qvm Kiv hvq|

1. KZé` I `vqZj cvj`bi t`j`i Avb`gmbK, wmt`÷gi evBti weifba mvgwRK, ivR`w`ZK `jexZv KvR Kti |
2. `jgZv w`fba`j ev `j`mwoi Kv`Q Qov`bv`\_v`K|
3. Avb`gmbK Ges Avb`gmbK j`j`i gta` c`QKB msNvZ nq Avb`gmbK j`j`i Rb` bvbvgyx w`b`Rbv Av`m|
4. thw`v`thvM msukó `j mg`ni `v`AbyiY Kti Ptj |
5. w`fba`tji Avb`gmbK ev Av`k`v Øviv Drcv`b e`e`v (w`Lb-tkLv`bv Kvh`g) w`bq`šZ nq|
6. Aa`biv c`QKB DaY`Zb`i Pw`j`q`tbq|
7. ØØ ev msNvZ Kv`h`c`thvM (MVbgj K) Ges Acwi`nv`etj g`tb Kiv nq|
8. Avw`R w`l`q Qvov Ab`v` w`l`q Aa`b`i gta` t`c`Yv mwó Kti |
9. KvR Ki`Z bv Pvl`qvUv gvby`i Pwi`i`i Aš`b`h`Z `eukó` bq, GilU Zvi AvRZ `eukó` (Learned Behaviour) |
10. c`Z`K e`w³ Kg`j`i`i Abb` mvgwRK I g`b`v`Áv`bK `eukó` w`b`q Av`m Ges w`bR w`bR Ae`v`b ev f`vgKv t`\_tK Drcv`b e`e`v`K c`f`meZ Kti |



**cv#VĒi gj`vqb: 2**

**A) eū ubePbx cĕæ**

m#WK DĒi ūb#`Rgj-K Aŋi#U#K eĒv#qZ Kiab| (D`vniY: Avcbvi ūbe#PZ DĒi#U K ntj G#K (K) eĒv#qZ Kiab)

1. ūPivqZ Z#Ēj tKv#U#i Dci , i#Zj Av#ivc Kiv nq?  
 K. e`#Zj  
 L. Av#eM Ab#v#Z  
 M. Drcv`b  
 N. gvbe m#úK#
2. nLY#ngx#ŋv Abv#i k#gK#`i t#ŋYv m#ó#i Rb` me#P#q , i#ZcY#e#lq tKv#U#?  
 K. KZ#j.k#Lj  
 L. m#gv#RK m#úK#  
 M. Kv#Ri kZ#ej x  
 N. gRjx|
3. m#gv#RK msMV#bi t#ŋ#ŋ tKv#U# c#h#R` bq?  
 K. msMV#b Abv#ŋ#bK `tj i Ae`vb  
 L. k#gK#`i AskM#Y  
 M. msMV#bi m#t\_ k#gK#`i GKvZ#v#eva  
 N. e`e`vc#vi M#Z c#k#Z.m#ú#K#k#gK#`i Abv`v|

**Av) ms#ŋ#B DĒi cĕæ**

1. m#gv#RK ZĒj D#m#ei t#ŋ#ŋ n\_Y#ngx#ŋvi f#gKv Kx?
2. m#gv#RK msMVb Z#Ēj K#qK#U#`e#k#ó` D#j#L Kiab|
3. e`e`vcK I k#gK#`i g#t#`ŋ` ūbim#bi Rb` ūK#mi Dci tRvi t`lqv nq?
4. D`vniYmn m#gv#RK ūm#÷#gi `e#k#ó` , tjv D#j#L Kiab|
5. ūe`vj#q ūK ai#bi m#gv#RK ūm#÷#g ūeivR K#i Zvi GK#U# eY#v ū`b|



**m#WK DĒi**

A) 1| M, 2| L, 3| N|

**cW 3**

### Dvgj vnt÷g ZËj

#### Dt`k`

GB cW tk`l Avcib—

- Dvgj vnt÷g ZËj ej tZ wK ešvq Zv e`vL`v Ki tZ cvi teb;
- Dvgj l ex vnt÷tgi gta` cv`R` wbjcY Ki tZ cvi teb Ges
- wPivqZ ZËj l Dvgj vnt÷g ZtËj avi YvMZ cv`R` Dtj`L Ki tZ cvi teb |

#### fvgKv

1960 Gi `k`k bZb chjyš wbfP mgv`R Dvgj vnt÷g ZtËj D`e nq | wPivqZ l mivgwRK ZËj `w`jZ msMVBtK Zvi Pricv`ki cvi tek n`Z wew`QbæGKwU ex vnt÷g (Closed System) vntmte K`bv Kivi cËYZv t`Lv hvq | Dvgj vnt÷g ZtËj msMVBtK GK „Q ci`úi m`úKŋy A½ vntmte K`bv Kiv nq th`tjv cvi te`ki mnt` GKwU Rxeš`c`ŋxi gZ wvqv-c`Zwvqv Kti | A`P Dvgj vnt÷g ZËj cvi te`ki mnt` Nwbôfite m`úwKZ Ges cvi tek wbtqB Gi KvRKvi evi | GLv`b msMVb cvi tek n`Z gvbe l e`MZ m`úK, gj`teva, mgv`Ri Avkv-AvK•Lv, Pwv`v BZ`w` thvMvb (Input) vntmte cvq; G`tjv`K Drcv`b c`wvqi (thgb- tkŋy wKŋY Kvhpig) gva`tg ifcvšhi Z Kti Ges Drcv` Z cv` (thgb wKŋY e`wš, bZb Avb, bZb gj`teva) c`vrvq e`emv, wKŋv, Mq l tmevgj-K c`Zôv`b Z`v cvi te`k weZiY ev iBvbx Kti | c`Zôv`b G Kv`Ri Rb` mgv`Ri wBKU t`tK Av`R mnt`hvMZvi ga` w`tq c`Z`vb cvq hv Zv`K w`tK `vKtZ l Dbq`bi ct` Pj tZ mrvqZv Kti | GfiteB c`Zôv`bi KvR PwvKviti Pj tZ `v`K |

### ve`ij q l Dvgj vnt÷g ZËj

tKvb c`Zôv`B m`wK A`c`tjivcvi Dvgj ev ex bq | GKwU c`tjivcvi ex vnt÷g Zvi Drcv`b e`e`vi Rb` tKvb gvbe ev e`MZ m`ú` thvMvb vntmte cvte bv Ges cvi te`k tKvb Drcv` Z cv` l weZiY Ki tZ cvi te bv | AZGe, G ai`bi vnt÷tgi tKvb Av`Zl `vKtZ cvti bv | c`ŋvšti c`tjivcvi Dvgj vnt÷tgi tKvb wbePbx ev evQvB c`wvqv `vKte bv etj GwU Kv`c`v Pvj bv AZ`w`K Z` Ges Ac`wvRbxq KvPvgj švrv fivvš`ntel | AZGe tKvb c`Zôv`b c`tjivcvi Dvgj bv ex Gfite wPšl bv Kti c`Zôv`wU tKvb w`tkl wv`všl ev P`ci g`L wK cvigv`Y Dvgj ev ex Zv wetePbv KivB Av`K hvy`m`šZ | D`vniY`f`c ejv hvq, GKwU `ž` nqZ wKŋv`vug m`úwKZ w`tq Awf`vKt`i civgk` Mh`Yi tejvq ht`ó Dvgj n`Z cvti | Avevi Qv`t`i k;Ljv w`lqK w`bqKvb`bi tejvq civgk`Mh`Yi šex`0 n`Z cvti | AZGe b`bv ai`bi w`tq wv`všl Mh`Yi c`kæGKwU `ž` w`vfbægv`vq Dvgj ev ex n`Z cvti | Z`bvvgj-K w`Piti tKvb tKvb c`Zôv`b ev msMVBtK ōDvgj`-ex`0 gv`v t`fj i tKvb GKw`tK GKUz`enK S`K co`tZ t`Lv hvq | Avgv` i t`tki miKvix `ž`tjv A`bKuv ex vnt÷tgi Abj`c | G`tjv`K Qv`t`i Rb` Ab` c`Zôv`bi mnt` c`Z`thvMZv Ki tZ nq bv, w`tK `vKvi Rb` tKvb msMŋgl Ki tZ nq bv | G`tjvi



Aw-Zi GKIKg ubwōZB ejv hvq| G<sub>3</sub>tjvi A<sub>3</sub>qbl Kg<sup>3</sup>qZv ev mvd<sub>3</sub>tj<sub>3</sub>i m<sub>3</sub>t<sub>3</sub>  
 Nubōf<sub>3</sub>vte m<sub>3</sub>ú<sub>3</sub>KZ<sub>3</sub> bq| A<sub>3</sub>q G<sub>3</sub>tjvi Qv<sub>3</sub>tiv cieZ<sub>3</sub>Z<sub>3</sub> tKvb wek<sub>3</sub>te<sub>3</sub> `ij q ev Ktj<sub>3</sub>tR<sub>3</sub> f<sub>3</sub>vZ<sub>3</sub><sup>3</sup>  
 n<sub>3</sub>tZ<sub>3</sub> cvij<sub>3</sub> wKbv<sub>3</sub>, b<sub>3</sub>wK<sub>3</sub> teKvi Ae<sub>3</sub>-<sub>3</sub>vq c<sub>3</sub>t<sub>3</sub> c<sub>3</sub>t<sub>3</sub> N<sub>3</sub>tj<sub>3</sub> teovj Z<sub>3</sub>v<sub>3</sub>Z<sub>3</sub> wKQyAv<sub>3</sub>t<sub>3</sub>m hvq bv|  
 G<sub>3</sub>tjv eQi eQi tgvUv<sub>3</sub>g<sub>3</sub>w GKB iKg Aw<sub>3</sub>R<sub>3</sub> eiv<sub>3</sub> ev thvMvb tctq hv<sub>3</sub>t<sub>3</sub>"Q| Ab<sub>3</sub>w<sub>3</sub>tK<sub>3</sub>  
 tewki f<sub>3</sub>vM temiKvix c<sub>3</sub>ōZōvb I ṽ n<sub>3</sub>t<sub>3</sub>"Q<sub>3</sub> `eikó<sub>3</sub>"MZf<sub>3</sub>vte D<sub>3</sub>g<sub>3</sub><sup>3</sup> c<sub>3</sub>KwZ<sub>3</sub>i| G<sub>3</sub>tjvi Aw<sub>3</sub>-Z<sub>3</sub>  
 ubwōZ bq, w<sub>3</sub>tK<sub>3</sub> <sub>3</sub>vKvi Rb<sub>3</sub>" G<sub>3</sub>tjv<sub>3</sub>tK<sub>3</sub> msMōg<sub>3</sub> Ki<sub>3</sub>tZ<sub>3</sub> nq| G<sub>3</sub>tjv<sub>3</sub> w<sub>3</sub>tR<sub>3</sub>t<sub>3</sub>i c<sub>3</sub>ōqvRb  
 Ab<sub>3</sub>lvqx MōnK ev Qv<sub>3</sub>t<sub>3</sub> wbe<sub>3</sub>P<sub>3</sub>b K<sub>3</sub>t<sub>3</sub>i| G<sub>3</sub>t<sub>3</sub>i A<sub>3</sub>q<sub>3</sub>b I mn<sub>3</sub>thvMZ<sub>3</sub>v w<sub>3</sub>b<sub>3</sub>f<sub>3</sub>P<sub>3</sub> K<sub>3</sub>t<sub>3</sub>i Kg<sup>3</sup>qZv I  
 Drcv<sub>3</sub>t<sub>3</sub>bi <sub>3</sub>Y<sub>3</sub>v<sub>3</sub>t<sub>3</sub>Yi Dci| G<sub>3</sub>tjv m<sub>3</sub>ú<sub>3</sub> `AvniY I wecY<sub>3</sub>t<sub>3</sub>bi Rb<sub>3</sub>" ci<sub>3</sub>-ú<sub>3</sub>i c<sub>3</sub>ōZ<sub>3</sub>thvMZ<sub>3</sub>vq  
 w<sub>3</sub>j<sub>3</sub> B nq Ges KL<sub>3</sub>t<sub>3</sub>bv KL<sub>3</sub>t<sub>3</sub>bv G<sub>3</sub>tjvi Aw<sub>3</sub>-Z<sub>3</sub>i wecb<sub>3</sub>æ<sub>3</sub>ev wej<sub>3</sub>xb nq| `f<sub>3</sub>veZB te<sub>3</sub>p<sub>3</sub> <sub>3</sub>vKvi Rb<sub>3</sub>"  
 Gme c<sub>3</sub>ōZōvb<sub>3</sub>tK<sub>3</sub> c<sub>3</sub>w<sub>3</sub>i<sub>3</sub>t<sub>3</sub>et<sub>3</sub>ki c<sub>3</sub>w<sub>3</sub>i<sub>3</sub>eZ<sub>3</sub>ō<sub>3</sub>K<sub>3</sub>xj P<sub>3</sub>w<sub>3</sub>n<sub>3</sub> `vi m<sub>3</sub>t<sub>3</sub>-mgš<sub>3</sub>q<sub>3</sub> K<sub>3</sub>t<sub>3</sub>i P<sub>3</sub>j<sub>3</sub>tZ<sub>3</sub> nq|

**wPivqZ ZĒj I D<sub>3</sub>g<sub>3</sub><sup>3</sup> ZtĒj g<sub>3</sub>t<sub>3</sub>" cv<sub>3</sub>R<sub>3</sub>"**

wPivqZ ZĒj Ges D<sub>3</sub>g<sub>3</sub><sup>3</sup> w<sub>3</sub>t<sub>3</sub>-g<sub>3</sub> ZtĒj g<sub>3</sub>t<sub>3</sub>" avi YwMZ cv<sub>3</sub>R<sub>3</sub>"<sub>3</sub> t<sub>3</sub>jv<sub>3</sub> w<sub>3</sub>t<sub>3</sub>p<sub>3</sub> D<sub>3</sub>t<sub>3</sub> L Kiv nj :

- | <b>wPivqZ ZĒj</b>   | <b>D<sub>3</sub>g<sub>3</sub><sup>3</sup> w<sub>3</sub>t<sub>3</sub>-g<sub>3</sub> ZĒj</b>   |
|---|--|
| 1. msMV <sub>3</sub> t <sub>3</sub> bi `eikó <sub>3</sub> " nj Aa <sub>3</sub> -b <sub>3</sub> t <sub>3</sub> -t <sub>3</sub> K <sub>3</sub> Da <sub>3</sub> Ÿ <sub>3</sub> Z <sub>3</sub> b c <sub>3</sub> - <sub>3</sub> μ <sub>3</sub> t <sub>3</sub> g <sub>3</sub> KZ <sub>3</sub> ® I `w <sub>3</sub> qZ <sub>3</sub> i cvj <sub>3</sub> b Kiv nq | 1. msMV <sub>3</sub> t <sub>3</sub> bi `eikó <sub>3</sub> " nj Dc <sub>3</sub> -w <sub>3</sub> t <sub>3</sub> -g <sub>3</sub> t <sub>3</sub> jv <sub>3</sub> Af <sub>3</sub> -š <sub>3</sub> t <sub>3</sub> i Ges ci <sub>3</sub> -ú <sub>3</sub> t <sub>3</sub> i g <sub>3</sub> t <sub>3</sub> " b <sub>3</sub> v <sub>3</sub> b <sub>3</sub> ai <sub>3</sub> t <sub>3</sub> bi NUb <sub>3</sub> v <sub>3</sub> P <sub>3</sub> t <sub>3</sub> μ <sub>3</sub> i m <sub>3</sub> st <sub>3</sub> h <sub>3</sub> M <sub>3</sub> KvR <sub>3</sub> K <sub>3</sub> t <sub>3</sub> i   |
| 2. q <sub>3</sub> gZ <sub>3</sub> v c <sub>3</sub> ā <sub>3</sub> v <sub>3</sub> b KgRZ <sub>3</sub> P <sub>3</sub> ev wbe <sub>3</sub> f <sub>3</sub> x <sub>3</sub> i w <sub>3</sub> bKU <sub>3</sub> t <sub>3</sub> K <sub>3</sub> w <sub>3</sub> `f <sub>3</sub> Z <sub>3</sub> <sub>3</sub> v <sub>3</sub> t <sub>3</sub> K <sub>3</sub>           | 2. q <sub>3</sub> gZ <sub>3</sub> v Dc <sub>3</sub> w <sub>3</sub> t <sub>3</sub> -g <sub>3</sub> t <sub>3</sub> jv <sub>3</sub> g <sub>3</sub> t <sub>3</sub> " Qov <sub>3</sub> t <sub>3</sub> bv <sub>3</sub> v <sub>3</sub> t <sub>3</sub> K <sub>3</sub>  |
| 3. Avbō <sub>3</sub> w <sub>3</sub> bK <sub>3</sub> j <sub>3</sub> q <sub>3</sub> t <sub>3</sub> -t <sub>3</sub> K <sub>3</sub> NUb <sub>3</sub> v <sub>3</sub> ev Kv <sub>3</sub> t <sub>3</sub> Ri w <sub>3</sub> K <sub>3</sub> w <sub>3</sub> t <sub>3</sub> `R <sub>3</sub> bv Av <sub>3</sub> t <sub>3</sub> m                                    | 3. c <sub>3</sub> w <sub>3</sub> i <sub>3</sub> t <sub>3</sub> et <sub>3</sub> ki P <sub>3</sub> w <sub>3</sub> n <sub>3</sub> `v I c <sub>3</sub> ōqvRb t <sub>3</sub> -t <sub>3</sub> K <sub>3</sub> NUb <sub>3</sub> v <sub>3</sub> ev Kv <sub>3</sub> t <sub>3</sub> Ri w <sub>3</sub> K <sub>3</sub> w <sub>3</sub> t <sub>3</sub> `R <sub>3</sub> bv Av <sub>3</sub> t <sub>3</sub> m  |
| 4. thvM <sub>3</sub> thvM <sub>3</sub> c <sub>3</sub> ōZ <sub>3</sub> wōZ <sub>3</sub> g <sub>3</sub> vā <sub>3</sub> g <sub>3</sub> Ab <sub>3</sub> lvqx P <sub>3</sub> t <sub>3</sub> j   | 4. thvM <sub>3</sub> thvM <sub>3</sub> mgMō <sub>3</sub> w <sub>3</sub> t <sub>3</sub> -g <sub>3</sub> e <sub>3</sub> -v <sub>3</sub> c <sub>3</sub> x <sub>3</sub> P <sub>3</sub> t <sub>3</sub> j hv <sub>3</sub> t <sub>3</sub> Z <sub>3</sub> Dc <sub>3</sub> w <sub>3</sub> t <sub>3</sub> -g <sub>3</sub> t <sub>3</sub> jv <sub>3</sub> K <sub>3</sub> t <sub>3</sub> Ri mgš <sub>3</sub> q <sub>3</sub> Kiv hvq Ges c <sub>3</sub> w <sub>3</sub> i <sub>3</sub> t <sub>3</sub> et <sub>3</sub> ki m <sub>3</sub> t <sub>3</sub> -m <sub>3</sub> st <sub>3</sub> h <sub>3</sub> M <sub>3</sub> m <sub>3</sub> vab <sub>3</sub> Kiv hvq |
| 5. msMV <sub>3</sub> t <sub>3</sub> bi w <sub>3</sub> bqgK <sub>3</sub> v <sub>3</sub> b <sub>3</sub> t <sub>3</sub> bi Øv <sub>3</sub> v <sub>3</sub> Drcv <sub>3</sub> -b e <sub>3</sub> -e <sub>3</sub> -v <sub>3</sub> i Dci w <sub>3</sub> bqš <sub>3</sub> Ÿ <sub>3</sub> c <sub>3</sub> ōZōv <sub>3</sub> Kiv nq                                 | 5. Dc <sub>3</sub> w <sub>3</sub> t <sub>3</sub> -g <sub>3</sub> t <sub>3</sub> jv <sub>3</sub> m <sub>3</sub> t <sub>3</sub> -c <sub>3</sub> w <sub>3</sub> i <sub>3</sub> t <sub>3</sub> et <sub>3</sub> ki m <sub>3</sub> v <sub>3</sub> R <sub>3</sub> m <sub>3</sub> st <sub>3</sub> h <sub>3</sub> M <sub>3</sub> m <sub>3</sub> vā <sub>3</sub> t <sub>3</sub> bi g <sub>3</sub> vā <sub>3</sub> t <sub>3</sub> g <sub>3</sub> Drcv <sub>3</sub> -b e <sub>3</sub> -e <sub>3</sub> -v <sub>3</sub> i Dci w <sub>3</sub> bqš <sub>3</sub> Ÿ <sub>3</sub> c <sub>3</sub> ōZ <sub>3</sub> wōZ <sub>3</sub> nq                              |
| 6. ØØ msMV <sub>3</sub> t <sub>3</sub> bi Rb <sub>3</sub> " q <sub>3</sub> wZK <sub>3</sub> i hv w <sub>3</sub> bqj <sub>3</sub> -K <sub>3</sub> iv c <sub>3</sub> ōqvRb  | 6. ØØ Ac <sub>3</sub> w <sub>3</sub> i <sub>3</sub> n <sub>3</sub> ih <sub>3</sub> ® hvi m <sub>3</sub> g <sub>3</sub> ō <sub>3</sub> k <sub>3</sub> x <sub>3</sub> j e <sub>3</sub> -e <sub>3</sub> -v <sub>3</sub> c <sub>3</sub> bv msMV <sub>3</sub> t <sub>3</sub> Ab <sub>3</sub> k <sub>3</sub> j c <sub>3</sub> w <sub>3</sub> i <sub>3</sub> eZ <sub>3</sub> ® Av <sub>3</sub> bq <sub>3</sub> t <sub>3</sub> b m <sub>3</sub> v <sub>3</sub> q <sub>3</sub> K <sub>3</sub>   |
| 7. tK <sub>3</sub> vb K <sub>3</sub> vR m <sub>3</sub> ú <sub>3</sub> v <sub>3</sub> t <sub>3</sub> bi GK <sub>3</sub> w <sub>3</sub> UB gv <sub>3</sub> Ī m <sub>3</sub> te <sub>3</sub> f <sub>3</sub> Ēg <sub>3</sub> c <sub>3</sub> š <sub>3</sub> v i <sub>3</sub> t <sub>3</sub> q <sub>3</sub> t <sub>3</sub> Q                                  | 7. tK <sub>3</sub> vb K <sub>3</sub> vR m <sub>3</sub> ú <sub>3</sub> v <sub>3</sub> t <sub>3</sub> bi Rb <sub>3</sub> " mg <sub>3</sub> f <sub>3</sub> vte m <sub>3</sub> t <sub>3</sub> š <sub>3</sub> l <sub>3</sub> RbK w <sub>3</sub> e <sub>3</sub> f <sub>3</sub> b <sub>3</sub> æ <sub>3</sub> c <sub>3</sub> š <sub>3</sub> v i <sub>3</sub> t <sub>3</sub> q <sub>3</sub> t <sub>3</sub> Q   |
| 8. msMV <sub>3</sub> t <sub>3</sub> bi w <sub>3</sub> Kf <sub>3</sub> vte K <sub>3</sub> vR Kiv D <sub>3</sub> w <sub>3</sub> PZ t <sub>3</sub> m m <sub>3</sub> ú <sub>3</sub> t <sub>3</sub> K <sub>3</sub> ® Av <sub>3</sub> t <sub>3</sub> j <sub>3</sub> vK <sub>3</sub> cvZ <sub>3</sub> K <sub>3</sub> t <sub>3</sub> i                          | 8. msMV <sub>3</sub> b w <sub>3</sub> Kf <sub>3</sub> vte K <sub>3</sub> vR Ki <sub>3</sub> t <sub>3</sub> Q t <sub>3</sub> m m <sub>3</sub> ú <sub>3</sub> t <sub>3</sub> K <sub>3</sub> ® Av <sub>3</sub> t <sub>3</sub> j <sub>3</sub> vK <sub>3</sub> cvZ <sub>3</sub> K <sub>3</sub> t <sub>3</sub> i   |
| 9. e <sub>3</sub> x Ges c <sub>3</sub> w <sub>3</sub> i <sub>3</sub> t <sub>3</sub> et <sub>3</sub> ki n <sub>3</sub> tZ <sub>3</sub> w <sub>3</sub> e <sub>3</sub> r <sub>3</sub> Q <sub>3</sub> b <sub>3</sub> ø  | 9. D <sub>3</sub> g <sub>3</sub> <sup>3</sup> Ges Input-Output c <sub>3</sub> ō <sub>3</sub> μ <sub>3</sub> qv <sub>3</sub> i g <sub>3</sub> t <sub>3</sub> " w <sub>3</sub> t <sub>3</sub> q <sub>3</sub> c <sub>3</sub> w <sub>3</sub> i <sub>3</sub> t <sub>3</sub> et <sub>3</sub> ki m <sub>3</sub> t <sub>3</sub> -w <sub>3</sub> μ <sub>3</sub> qv <sub>3</sub> K <sub>3</sub> t <sub>3</sub> i   |
| 10. m <sub>3</sub> ú <sub>3</sub> K <sub>3</sub> ®GKB iKg Ae <sub>3</sub> - <sub>3</sub> vq ev `we <sub>3</sub> i Ae <sub>3</sub> - <sub>3</sub> vq <sub>3</sub> v <sub>3</sub> t <sub>3</sub> K <sub>3</sub>   | 10. m <sub>3</sub> ú <sub>3</sub> t <sub>3</sub> K <sub>3</sub> ®M <sub>3</sub> z <sub>3</sub> g <sub>3</sub> q <sub>3</sub> Z <sub>3</sub> v <sub>3</sub> v <sub>3</sub> t <sub>3</sub> K <sub>3</sub>  |
| 11. Povš <sub>3</sub> KZ <sub>3</sub> Z <sub>3</sub> i I `w <sub>3</sub> qZ <sub>3</sub> i g <sub>3</sub> L <sub>3</sub> " KgRZ <sub>3</sub> ® n <sub>3</sub> tZ <sub>3</sub> <sub>3</sub> v <sub>3</sub> t <sub>3</sub> K <sub>3</sub>   | 11. g <sub>3</sub> L <sub>3</sub> " KgRZ <sub>3</sub> ®K <sub>3</sub> Ggb A <sub>3</sub> t <sub>3</sub> bK <sub>3</sub> NUb <sub>3</sub> v <sub>3</sub> i KZ <sub>3</sub> Z <sub>3</sub> i I `w <sub>3</sub> qZ <sub>3</sub> i w <sub>3</sub> t <sub>3</sub> Z <sub>3</sub> nq hv Z <sub>3</sub> v <sub>3</sub> w <sub>3</sub> t <sub>3</sub> Ri m <sub>3</sub> ō <sub>3</sub> bq Ges w <sub>3</sub> bqš <sub>3</sub> t <sub>3</sub> Y <sub>3</sub> i bq   |



**cɪvVĔi gj`iqb: 3**

**A) eú ɪbePbx cĕœ**

mɪWK DĔi ɪbɪ` Rgj-K AŋiɪUɪK eĔvɪqZ Kiab | (D`vniY: Avcbvi ɪbePZ DĔiɪU K ntj GɪK (K) eĔvɪqZ Kiab)

1. Dɔgʃ ɪmɪ÷g ZɪĔj tKɪvɪUɪK GK ˚Q ci ˘úí m˚úKɪŋ A½ ɪntmɛ Kíbv Kiv nq?
  - K. RɛšcĕYɪK
  - L. cɪiɪɛkɪK
  - M. ɪɪqv cĔZɪɪqvɪK
  - N. mɪMvɪK |
  
2. cɪjvcɪj Dɔgʃ ɪmɪ÷tg mɪMvɪbi tŋɪɪ tKɪvɪU NɪU?
  - K. cɪiɪɛk nɪZ thɪMvb cvq bv
  - L. AZ`ɪwɪK Z ˚ ɔvɪv fɪvɪɪvšɪng
  - M. Drcɪv` Z cY` cɪiɪɛk ɪeZiY KiɪZ cvɪi bv
  - N. ɪbePbx ev evQvB cĕɪqv KvR Kɪi |
  
3. Avgvɪ` i t`ɪki miKɪvi ˘ǰ ˚tjv ex cĕɪzi, KvɪY G ˚tjv
  - K. ɪbɪɪɪ` i cĕqvRb Abɪvqɪ Qvɪ ɪbePb ev fɪZKɪi
  - L. Ab` ˘ǰ ˚tjvi mɪɪ\_ cĕɪthɪMzv Kɪi
  - M. cɪiɪɛkɪ Pɪvɪ`vi mɪɪ\_ mgšq KivɪK Dɪcŋv Kɪi
  - N. Av`ɪZj Rb` ɪbi šɪ mɪMg Kɪi |

**Av) mɪɪŋB DĔi cĕœ**

1. mɪMv cɪiɪɛkɪ mɪɪ\_ ɪKfɪɛ PɪvKvɪi KvR Kɪi?
2. tKɪv cĔZôvB cɪjvcɪj Dɔgʃ ev ex bq- e`vL`v Kiab |
3. Avgvɪ` i t`ɪki temiKɪvi ˘ǰ ˚tjv Dɔgʃ bv ex cĕɪzi? e`vL`v Kiab |



**mɪWK DĔi**

A) 1 | N, 2 | L, 3 | M |



cw 1

## g'v tftei (1864-1920): Avgj vZtšj AMÖZ

### Dt'k

GB cw tktl Avcb—

- g'v tftei-Gi Avgj vZwšK bñZ, tj v eYØv KiřZ cviřeb Ges
- Avgj vZtšj mjeav I Amjeav Dtjl KiřZ cviřeb|

### figKv

g'v tfteitK (Max Weber) Avgj vZwšK c'kymb ZtEji AMÖZ intmte MY" Kiv nq| Rvgb mgvRZtEje` g'v tftei cġg uekhy ceZKvtj miKmi, migwiK Ges e'emvqK cġZövmgtñi KihexwZ I KZšj Kvtgv wtq Mtel Yv Ktib Ges Avgj vZtšj ZtEjq ueKvk m'ab Ktib| Avgj vZšj m'útK'Zui gE` avi Yv, tj v wZwb Zui "The Theory of Social and Economic organization" bvgK Mš' Dc vcb Ktib|

### Avgj vZwšK bñZgvj v

tftei GK, "Q ōmsMVwbK bñZiō msÁv cġvb Ktib Ges G, tj vtK cġqmthvM'Zvi w`K t\_řK meRbxb etj Dtjl Ktib| Zui gřZ G bñZ, tj v Aejaþ Kiv nřj tKvb msMVb mteP `řZv ARB KiřZ mřlg nte| bñZ, tj v nřj v:

### c` tmvcb Kwřgv (Hierarchical Structure)

msMVtbi KZšj D'P t\_řK µgvřq wtPi w`řK ucimřWi AvKvti b`řnte| Gi A\_řj Avgj vZtšj me, tj v c` gvbµgvbřvqx Dci t\_řK wtPi w`řK mmiex Kiv nq| GLvřb Kgř'i gřřS mmbqi Rřbqi m'úK'itřq, cġZřKB Rvřb řK Kvi KvR ZĖjeavb I wbgšř Kiřeb Ges řK wtřZvi Kvtři Rb" Kvi Kvtř Reven`nř Kiřeb| dtj G e'e`řq msMVtbi tKvb c` B wbgšř ev ZĖjeavtbi evřti vřK bv|

### křgi uefvRb (Division of Labour)

msMVtbi mKj KvR `řZv I ueřklvřbi wřvĖřZ fvM Kti m'úbæKiřZ nte| msMVtbi bvbneav KvR cġZřK e'w'i cřř mgvb `řZvi mř\_ AvqZj Kiv m'e bq| mřivis msMVtbi KvR, tj vtK KZ, tj v ueřklvřb řřř intmte fvM Kti Kgř'i cġkřřY, `řZv I AvřÁZv Abřvqx Hme řřř wtřqmRZ Kiřj Avakzi `řZv ARB Kiv m'e nte|

### wbgg I vevaveavb (Rules and Regulation)

Avgj vZtšj GKwU, iazřY`enkó" nj th, Gw GK, "Q wbgg I vevaveavb Øriv cwġřřř Z nq| msMVtbi Kivřevj I Kgř'i AvřiY wbgšřři Rb" Avdm KZř. GK, "Q wbgg,

ḡ Ae GW#Kkb

weawaeavb I c×wZ cŷvZ nq| Gi dtj msMV#bi Kv#Ri avivevwnKZv, ḡwqZj Ges ce#Fv m cŷvb wbuōZ Kiv hvq|

**be#KZv (Impersonal Relationship)**

msMV#bi hveZxq KivR weawae× wbgg Kivbly Ablyvqx cwi Pwvj Z nte, tKiv AvteM AblyvZ ev e#w<sup>3</sup>MZ cŷ, ms<sup>-</sup>vi GLv#b tKiv , iazj crte br| KtVvi fite wbggk;Ljv cwi Z ntj Kg# i Dci wbgšy Z\_v msMV#bi Kiv#ej i Dci wbgšy h\_vh\_fite cŷZwōZ nte|

**Kg#qZv (Expertise)**

Avvj vZšj Kg#wbtqvM Kiv nq thvM<sup>-</sup>Zv, Kwimwi Ávb I bctj<sup>-</sup>i wfiÉtZ| tR<sup>-</sup>ōZv Ges tgavi we#Pbvq c#vbwZ Ges c# i μgiblyvqx teZb cŷvb Kiv nq| Kv#RB c#kq#tYi gva<sup>-</sup>tg Kg# i thvM<sup>-</sup>Zv I qZv weKv#ki Dci , iazj Avtivc Kiv nq|

tftei gj-Z msMV#bi GKw AvbōmbK Kivv#gv wba#tYi Dci , iazj Avtivc Ki#Qb| Zu j q<sup>-</sup> wQj Ggb GKw Kivv#gv wba#tYi Kiv hv thšw<sup>3</sup>K wfiÉtZ wv<sup>-</sup>všl Mh#tYi KivRtK wL# I Zj wšZ Ki#Z m#qg nte| Avvj vZšj c#t# tftei th e<sup>3</sup>e<sup>-</sup> Dc<sup>-</sup>vcb Kti#Qb Zv nj :

“The most efficient form of administrative organization, because experts with much experience are best qualified to make technically correct decisions and because disciplined performance governed by abstract rules and coordinated by authority hierarchy fosters a rational and consistent pursuit of organizational objectives.”

**Avvj vZšj gj<sup>-</sup>vqb**

ievU<sup>g</sup>U<sup>g</sup> Avvj vZšj , Y eY<sup>g</sup> KivZ thtq D#t# Kti#Qb, “The chief merit of bureaucracy is its technical efficiency, with a premium placed on precision, speed, expert control, continuity, discretion and optimal returns of input.”

Avvj vZšj mgvtj vPbvq cŷqkB bvbv ai#bi t<sup>-</sup>vl μwDi K\_v D#t# Kiv nq| A#t#Ki gtZ Avvj vZšj e<sup>w</sup> i g#ta<sup>-</sup> fia I cimbfPkij g#bvfve Mto tZvtj | e<sup>w</sup> Zvi e<sup>w</sup> Zj; wemR<sup>g</sup> w<sup>-</sup>tq gwbtq Pjvi bwwZ Aej #b Kti | Avvj vZwšK c#vmb I e<sup>-</sup>vcbvi KtVvi wbgg I wea wbt#tai hvZvKtj e<sup>w</sup> D#<sup>-</sup>vM I mRbkij Zv webó nq| KZ#; GLv#b AmacZ<sup>-</sup>gj-K Ges AgivweK nq, e<sup>w</sup> i m#t<sup>-</sup> gvb#t i gZ bq htšj gZ AvPiY Kiv nq etj Kg# i g#tS we#kl Kti Aa<sup>-</sup>b Kg# i g#tS nZvkv mwó nq|



**cvtVĒi gj`vqb: 1**

**A) eū ubePbx cĕæ**

mĭWK DĒi ũbt`Rgj-K AŋiŭtK eĔvĭqZ Kiab | (D`vniY: Avcbvi ũbePZ DĒiŭ K ntj GtK (K) eĔvĭqZ Kiab)

1. Avgj vZtš;msMVtbi KZĖ;ŭKfvte ũeb`ĭnq?  
 K. GK „Q msvMvbK bŭzi ũfiĔtZ  
 L. Dci t\_tK ŭgvštq ũbtPi ũtK  
 M. tgavi ũfiĔtZ  
 N. `ŋZv l ũtKlvqtbŭ ũfiĔtZ |

2. msvMvbi `ŋZv ARĖ mæe nte ŭKfvte?  
 K. mKj c`gvbŭgvbŭvq ũeb`ĭKivi gva`tg  
 L. thšw³K ũfiĔtZ ũm×všĭMhŭYi gva`tg  
 M. ũtKlvqb tŋĭ ũntmte Kgĕ`i ũbtqvM Kti  
 N. KtVvi fvte ũbqg k;Lj v cij b Kti |

3. Kgĕ`i Reveŭ nxZvi Rb`tkvbŭ cĕqvRb?  
 K. msvMvb `beĕ³KZv  
 L. kŋgi ũefvRb  
 M. ũbqg l ũeŭa ũeavb  
 N. c`tmvcvb KvVtgv |

**Av) msvŋB DĒi cĕæ**

1. Avgj vZtš;msMVtbi tKvb c`B ũbqštYi evBti \_vtK bv, e`vL`v Kiab |
2. msvMvb `beĕ³KZv ej tZ ŭK tevSvq? Gi dj v dj ŭK?
3. Avgj vZtšj ũei t× AvfthvM ŭK ŭK?



**mĭWK DĒi**

A) 1 | L 2 | M, 3 | N |

**cW 2**

**tdWwi K DBYtjv tUj i (1856-1915): ᄡeÁmbK e'e-rcbvi RbK**

**DtIk**

GB cW tkfI Avrcib—

- ᄡeÁmbK e'e-rcbvi cxwzi ᄡofwz DtjL KitZ cvi teb;
- ᄡeÁmbK e'e-rcbvi bwxZgyjv DtjL KitZ cvi teb Ges
- ᄡeÁmbK e'e-rcbvi t'vl íau DtjL KitZ cvi teb|

**fvgKv**

tdWwi K DBYtjv tUj i (Frederick Winslow Taylor) nekjm KitZb tfsZ weÁvtbi tŋtŋ thgb cŋkwzK wbgg ev mF AvtQ tZgwb KvtrI tŋtŋ cŋkwzK wbgg ev mF itqtQ| A\_ŋ ᄡeÁmbK ᄡofwztZ tKvb KvtrI cŋkwZ chŋjvPbv Kti H KvRwU m'uv`tbi GKwU mteŋKó.cxwz wbyŋ Kiv m'el tUjtii AvtM KgŋvB wbaŋY KiZ GKwU KvR m'ubæKivi Rb" KZ mgq jvMte Ges wK cxwztZ Zv m'ubæKiv nte| tUj iB meŋŋg ᄡeÁmbK cxwz cŋqvm Kti RvbtZ Drmvr nb GKRB Kgŋ KZUKzkvR Kiv DvPZ| wZwb cŋg etj b, e'e-rcbvi ᄡwqZjnt"Q Kgŋ`i KvtrQ wK cŋvkv Kiv nt"Q tm m'utKZit`i Dct`k t`l qv Ges wKfvte Zviv KvR m'uv`b Kite tmwU wbr ŋ Kti t`l qv| GRb" B tUj itK ᄡeÁmbK e'e-rcbvi cxwzi RbK ejv nq| (The Father of Scientific Management)

**ᄡeÁmbK e'e-rcbvi bwxZgyjv**

tUj i 1911 m'tb cŋwvZ Zui Mŋs' The Principles of Scientific Management-G Zui gZvgZ e"3 Ktib| Zui gZvgtZi DtjL thvM" w K\_ tji vi msvŋŋBmvi Villers wbtgwe"i f#c Ztj atitQb:

**1. mgq-mgxŋv bwxZ (Time-study Principle)**

GKwU KvtrI weŋfbaer K\_ tji v w'ubæKivi Rb" KZUKzmgtqi cŋqvRb Zv cwi gvc KitZ nte Ges GKRB Kkjx Kgŋ Kvŋm'uv`tbi Rb" cŋgZ mgqmxgv (Standard Time) mwKfvte wbjcy KitZ nte|

**2. wcm-tiU bwxZ (Piece-rate Principle)**

cwi kŋgK nte Drcv`tbi AvbŋwzK Ges cwi kŋgtKi nvi wbfŋ Kite mgq-mgxŋv ŋvi wbyŋZ ÷ vŋwŋGi Dci| GKRB KgŋK mteŋP`tji th KvRwU tm KitZ mŋg nte tmwB w`tZ nte|





~ž Ae GW#Kkb

we#kIvqb KVR#K hvišK, GK#Ntq I AvKI#nY Kti tZvtj Ges Kg#`i gta" AZ#B.  
tertai m#o Kti |

weifc mgvtj vPbv m#Ej GK\_v Avgv#`i ~šitY ivL#Z nte th eÁmbK e'e`rcbv c#WZi  
mvd#j`i A#bKUVB wbf# Kti e'e`rcK I Kg#`i #PŠr I `#ofw# cwi eZ#bi Dci | G  
cwi eZ# mwaZ ntj A#bK mgvtj vPbvi Actbv`b nte etj g#b Kiv nq| hvB trvK, GUv  
Ab`#Kiv#th, e'e`rcbv I cwi KÍbv m#ú#KZ Avgv#`i A#bK AvaybK firebvi wfi#Eg#j  
i#q#Q tUj #i i Drcv`bk#j Zv e#x#i `#ofw#|



### **civVēi gj`iqb: 2**

#### **A) eū ubePbx cĕœ**

miWK DĒi ubt`Rgj-K AŋiUŋK eĚviqZ Kiab| (D`vniY: Avcbvi ubePZ DĒiU K ntj GtK (K) eĚviqZ Kiab)

1. tUj i meĒġg tKvbiU RvbZ Drmivx nb?  
 K. cĕKwZK ubqg ev mĒ  
 L. GKw KVR KiZ KZUKzngq cĕqvRb  
 M. GKRB Kgŋ KZUKzKVR Kiv DWPZ  
 N. tŋZ weAvtbi ubqg ev mĒ|
  
2. civi kĕgtKi nvi ubaŋi Z nte mgq-mgxŋv ōvi v, GwU tKvb bwiZ?  
 K. KvŋŋcŋŋMx e`e`vcbv bwiZ  
 L. wcm-tiU bwiZ  
 M. mgq-mgxŋv bwiZ  
 N. e`e`vcK KZR.ubqŋŋ bwiZ|
  
3. KvŋŋZ civi Kí bv c<sub>w</sub>KvKiY bwiZ Abŋvqx Kgŋ`i`vqZj nte tKvbiU?  
 K. iayKvŋŋi mŋzm`úv`b  
 L. iayKvŋŋi civi Kí bv cĕŋq  
 M. iaynteŋKó.Kvŋŋi c<sub>w</sub>Z ubaŋŋY  
 N. iayKvŋŋi cĕgZ mgq ubaŋŋY|

#### **Av) msuŋB DĒi cĕœ**

1. tUj i tK`eÁmbK e`e`vcbvi RbK ej v nq tKb?
2. `eÁmbK e`e`vcbvi bwiZ. tŋ v Dŋ L Kiab|
3. `eÁmbK e`e`vcbvi mvdj`wePvi Kiab|
4. `eÁmbK e`e`vcbvi t`vI-μwU eYŋv Kiab|



### **miWK DĒi**

A) 1| M, 2| L, 3| K|

**cW 3**

**tnbix d'vqj (1841-1925) Ges j yvi ,uj K: c#kymbK c#qvi c#<sup>3</sup>v**

**D#ik**

GB cW tk#l Av#b—

- e'e`vcbv m#ut#K d'vqj i avi Yv , t j v e`<sup>3</sup> Ki#Z cvi#eb;
- d'vqj c#E K#qK#W c#kymbK b#vZi D#j # Ki#Z cvi#eb;
- c#kymbK c#qvi m#ut#K j yvi ,uj #Ki avi Yv e`<sup>3</sup> Ki#Z cvi#eb Ges
- POSDCORB k#W e`vL`v Ki#Z cvi#eb/

**f#gKv**

*divm# ik'ic#Z tnbix d'vqj (Henry Fayol) c#kymb I e'e`vcbvi k#l#Kv#v#gvi avi Yv#Z melqv#j i Dci mel#l g#b#v#h#v#M #`b/ e'e`vcbvi Dcv`vb m#v#K#Z avi Yv , t j v nj Zui mel#P#q eo Ae`vb/ Z#K c#kymbK c#qvi RbK et#l Aw#v#Z Kiv nq/ #Z#b Zui Administration Industrille et Ge'nerale bvgK m#eL`vZ M#S' e'e`vcbvi c#qvi m#ut#K#h melq , t j vi D#j # K#ib tm , t j v nj : To forecast and plan, to organize, to command, to coordinate, and to control. Gm#ei e`vL`v c#h#Z #Z#b D#j # K#ib:*

To forecast and plan means examining the future and drawing up the plan of action. To organize means building up the dual structure, material and human, of the undertaking. To command means maintaining activity among the persons. To coordinate means binding together, unifying and harmonizing all activities and efforts. To control means seeing that everything occurs in conformity with established rule and expressed command.

**c#kymbK c#qvi b#vZgvj v**

*c#kymbK c#qvi m#ut#K d'vqj Dcvi D<sup>3</sup> th msAv c#vb K#ib Zv cieZ#K#v#t#j i e'e`vcbvi #P#st#v#v#t#K D#E#i#v#E#i c#F#me#Z K#i P#t#j#q/ G Q#v#v d'vqj GK , "Q b#vZgvj v ev Precepts-Gi msAv#l c#vb K#ib/ G , t j vi K#qK#W GL#v#b D#j # Kiv nj :*

e'e`vcK KZ#Z#Ki#eb Ges #Z#b—

1. Zui e`v<sup>3</sup>eM#m#ut#K#c#j#v#v#j AeinZ n#eb;
2. A#h#v#M#t`i Ac#v#i Y Ki#eb;
3. c#Z#v#b I Kg#`i e#v#b m#ut#K#m#g`K avi Yv j#v#f Ki#eb;

4. GKwU DEg `p'všl`vcb Kičeb;
5. cŁZŏvčbi chřqμgK wbi xŋY cwi Pvj bv Kičeb Ges mswŋŋBmvti i PwU©Zwi Kičeb;
6. cŁvb mnKvixt`i gta`bKU`vcčbi j tŋ` m t`đj b Abŋvb Kičeb Ges KvčRi Dci Avčj vKcivZ I wbt`Rbv cŁvb Kičeb;
7. cyLvbgyl mel tq Av`Qbančeb bv Ges
8. Kg@`i GKZv, kw³, Dt`vM I AvbMZ`weKvčki cŁZ j ŋ` ivLčeb|

d'vqtji cŁvmubK cŁμqvi wečkdY AbyriY Kti j yvi , ŋj KI cŁvmubK cŁμqvi KtqKwU , iazcyDcv`včbi K\_v Dčj L Ktib| wZwb cŁvmubK cŁμqvi newfbæDcv`vb ev KvčRi Av`vŋi w`tq 'POSDCORB' bvtg GKwU kã`Zwi Ktib| wZwb P w`tq Planning, O w`tq Organization, S w`tq Staffing, D w`tq Directing, C w`tq Coordination, R w`tq Reporting Ges B w`tq Budgeting tevSvčZ tPtqtQb| wbtP G KvR , t j vi eYŋv t`I qv nj :

- **cwi Kí bv (Planning)**

cŁZŏvčbi j ŋ` ARŋbi Rb` cŁvčZ mek` Kvhřig I Kg@šv nj cwi Kí bv| KLb, tKv\_vq, Kvi ŋviv, wKfvčte wK KvR KičZ nče Zvi bKkvB nt`Q cwi Kí bv|

- **msMvb (Organizing)**

tKvb cŁZŏvčbi cwi Kwí Z Dt`k`vej ARŋbi Rb` Gi Rbkw³čK msMvZ KičZ nq| msMvb ejčZ tevSvq cŁZŏvčbi Dt`k` ARŋbi j tŋ` cŁZŏvčbi Kvhřevj i wefvRb I tkwYexKiY, `wqZmgčni msAv wbičy Ges KZŋ. I ŋgZvi Kvčtgv cŁZŏvčbiY hvčZ Kgŋv wR wR `wqZmgč h\_vh\_ cij čb mŋlg nq|

- **Kg@ms`vb (Staffing)**

Rbkw³ ev KgPvixt`i ŋvivB `zwi nq cŁZŏvčbi msMvb Kvčtgv| mčZivs cŁqvRbq Rbkw³ wbtqvm, Kg@`i cŁkŋY I KvčRi Abčj cwiček `Zwi Kiv Avek`K|

- **wbt`Rbv (Directing)**

mwwK wbt`Rbv Ōrov tKvb cŁZŏvčbi j ŋ` ARŋ mæ bq| KvčRB cŁZŏvčbi wbevřx KgRZŋMYčK wbi ev`Qbčvčte wmvšl`MŋY KičZ nq Ges Z`vbŋvqx KgPvixt`i mvariY I wečkl Avč`k ev wbt`Rbv cŁvb KičZ nq|

- **mgščmab (Co-ordinating)**

cŁZŏvčbi Kg@,` Ges newfbæwefvM-DcwefvčMi gta` mnčhwMZv I thvMvčhvM `vcčbi gva`tg hveZxq KvčRi mvgAm` weavb KivB nj mgšč mab| mgščqi dtj mKj KvčRi gta` HK` cŁZwŏZ nq Ges mvgwMkfvčte cŁZŏvčbi Kvg` MwZ eRvq \_včK|





**cv#VĚi gj`vqb: 3**

**A) eū ubePbx cĕæ**

m#WK DĚi ubt`Rgj-K Aŋiu#K eĚvqZ Kiab| (D`vniY: Avcbvi ubePZ DĚiu K ntj GtK (K) eĚvqZ Kiab)

1. d`vqtj i gtZ e`e`rcK tKvbuW Kiĕb?  
 K. DĚg `pŕšl`rcb Kiĕb  
 L. AthvM`i AcmviY Kiĕb  
 M. cyLvbyL nel tq Av`Obanteb bv  
 N. Dcti i me,tjv|
  
2. j yvi ,uj K cĕvmbK cĕuqvi KquW Dcv`vb ev Kv#Ri K\_v D#j L Kti#Qb?  
 K. 5  
 L. 6  
 M. 7  
 N. 8|
  
3. d`vqj Zvi ZĚej #Z Kvi Dci g#bmbĕk Kti#Q#j b?  
 K. e`e`rcK  
 L. we#kIÁ  
 M. klgK  
 N. Aa`b KgPvix|
  
4. POSDCORB kãu#i R Aŋi i w`tq #K tevS#b#v nq?  
 K. Reminding  
 L. Recommending  
 M. Reporting  
 N. Recording

**Av) msuŋB DĚi cĕæ**

1. d`vqtj i KtqK#W cĕvmbK b#Z ev Precept D#j L Kiab|
2. POSDCORB kãu#i e`vL`v w`b|
3. tUj i I d`vqtj i gta`ngj -Avqj D#j L Kiab|



**m#WK DĚi**

A) 1| N, 2| M, 3| K, 4| M|

**cW 4**

**Gj Ub tḡtqv (1880-1949) ḡvbieK mṽúKᶜZtĒj cĔ<sup>3v</sup>**

**DtĪk**

GB cW tkĪl AvcĪb—

- ḡvbieK mṽúKᶜZĒj weKvĪki cUfḡ Dtj Ī KiĪZ cviġeb;
- ḡvbieK mṽúKᶜZĒj ej tZ wK tevSvq Zv eṽLṽ KiĪZ cviġeb Ges
- ḡvbieK mṽúKᶜZtĒj ṽḡfṽ I cṽwZMZ w K, tḡv Dtj Ī KiĪZ cviġeb|

**fḡKv**

wesk kZvāxi cĪg KtqK ṽkK aĪi cĪkmb I eṽṽcbvi tḡtĪ ḡvbe-mṽúKᶜI ṽjxq cĔPóvi Dci tKvb ṽiāz;cĪvb Kiv nZ bv| KZᶜcivqY cĪkmbKMY KtVvi fṽte Aaṽbṽi wḡqšY KiZ Ges Zvṽi Avṽ I mnṽhṽMZvi tKvb tZvqvṽ bv KĪi iayDrcvṽb eḡxi wĪK bRi w Z| meḡḡtĪ KwiMwi ṽbcYṽi Dci cĪavbṽ tṽqv nZ| G Aeṽvq nvi fṽWᶜ wekṽe ṽj tqi AaṽcK Gj Ub tḡtqv (Elton Mayo)-Gi wKQYMtēl YvKgᶜbZb wPšṽavi vi mPbv KĪi| Zui MṽelYv, tḡv hr cieZḡKvĪj n\_Yḡmḡḡṽv bṽḡ cĪmṽ jvf KĪi, eṽṽcbv KgṽvĪŪ AvPi wYK ṽḡfṽ weKvĪki c\_ Dbṽ KĪi| n\_Yḡmḡḡṽ, tḡvi j ḡṽ wQj Drcvṽb eḡxi Dci kḡgKĪi Kgᶜcwiġek, Kṽš, kṽš weiwZ, KgᶜNĒv, Drmṽn fṽZv, tḡZᶜ; BZṽw i cĪve KZUKzZv wḡjcy Kiv| eṽZ tḡtqv Ges Zui mnKgḡṽv Avtḡv, kā BZṽwṽ tḡšZ cwiġekMZ Dcvṽb cwiēZᶜ KĪi cixḡṽ wḡixḡṽ Pṽj tḡ wQṽb| i iāZ wZwb GB Abḡvḡ KĪi wQṽb th, Avtḡvi J<sup>3/4</sup>j, ṽf kā ev tKṽvṽj Ges KgᶜcwiġetĪki Dbḡb Drcvṽṽbi ev AvDUcṽṽi eḡx NUṽte| wKš cixḡṽvq ṽLv tMj GB Abḡvḡ mṽWK bq, kḡgKĪi wḡKU Gme ṽiāzcyᶜweṽePZ ntj I Gṽi ṽb wQZxq ṽṽb| ṽiāzcyᶜwēlq wntṽte cĪg ṽṽb i tḡtQ mḡvṽRK mṽúKᶜ wēlqṽ hr kḡgKĪi AvḡḡḡmbK ṽtj Afšṽi wēivRḡvḡ mḡvṽRK-gṽbṽeÁvḡbK Dcvṽb mḡḡḡni mṽ\_ mṽwK| A\_ṽ ZvrchēYᶜ th Z\_ wDṽNwZ nj Zvṽj GB th, Drcvṽb cĪṽqvi mṽ\_ eṽ<sup>3</sup> bq eis AvḡḡḡmbK ṽtj i mṽúKᶜṽB wētkl ṽiāzcyᶜ KviY kḡgKiv eṽ<sup>3</sup> wntṽte wṽqv cĪZwṽqv KĪi bv, eis cĪZṽKB GKw AvḡḡḡmbK ṽtj i mṽ wntṽte wṽqv-cĪZwṽqv KĪi ṽṽK| tKw ḡ KZᶜ; I Kivṽtḡvex wēiawēavṽbi evBṽi t\_ṽK kḡgKĪi AvḡḡḡmbK ṽj Drcvṽb cĪṽqvi wḡqšY MḡY KiĪZ cviġi, GB ZtĒj Aveᶜvi wPivqZ eṽṽcbv ZtĒj wṽwēṽ tḡ tḡvK Pḡḡvi KĪi tṽq Ges eṽṽcbvi tḡtĪ Human Relations ev ḡvbieK mṽúKᶜZtĒj mPbv KĪi |

**ḡvbieK mṽúKᶜZtĒj ṽeikó**

ḡvbieK mṽúKᶜZtĒj Kgᶜev eṽ<sup>3</sup> i mḡvṽRK-gṽbṽeÁvḡbK Pwṽṽ, tḡvi Dci AwāK ṽiāz; Avṽivc Kiv nq| dtj ZĒjU cĪkmb, eṽemv I wKḡṽi mṽ\_ mṽúMᶜZ mKj mṽMṽvḡbK KgṽvĪŪ ṽZ cĪṽi jvf KĪi| ḡvbieK mṽúKᶜZĒj cĪṽtṽ Mṽwṽvi (Burleigh B. Gardner)-Gi wḡtḡe<sup>3</sup> AwfḡZ ZĒjU i ṽḡfṽ Zḡj aĪi tQ:

Employees should have a feeling that the company's goal is worth their effort; they should feel themselves part of the company and take pride in their contributions to its goal. This means that the company's objectives must be such as to inspire confidence in the intentions of management and belief that each will get rewards and satisfactions by working for these objectives.

metPtq cwi ZB msMVb metPtq `q msMVb, GB AwfgZuU gvbueK muK<sup>©</sup>ZtEj E<sup>†</sup>al<sup>©</sup>Ztj  
aiv ntqtQ| AbvbgmbK `j ,tj vtK wejxb ev `gb Kivi cwietZ<sup>©</sup>G ,tjvi tg<sup>†</sup>ij K  
Pv<sup>†</sup> v ,tjv `Kvi Kti wbtq c<sup>†</sup>Z<sup>†</sup>vtbi jtq<sup>†</sup>i mt\_ Zv mvgÄm<sup>©</sup>c<sup>†</sup>Y<sup>©</sup>Kiv nq| m<sup>†</sup>aviYZ  
gvbueK muK<sup>©</sup>el<sup>†</sup>q AwfA I `q m<sup>†</sup>gvi fvBRviMY G `wqZj cvj b Kti \_vtK| G ZEj  
Ab<sup>†</sup>vti c<sup>†</sup>x<sup>†</sup>uZMZ w K t<sup>†</sup>K e<sup>†</sup>e<sup>†</sup>vcbvi t<sup>†</sup>q<sup>†</sup>t MYZ<sup>†</sup>ms<sup>†</sup>K i<sup>†</sup>uZb<sup>†</sup>uZ Ab<sup>†</sup>xyj b Kiv ntj Ges  
Kg<sup>†</sup>ewitek msMVtb I Db<sup>†</sup> th<sup>†</sup>M<sup>†</sup>thvM `vcbi t<sup>†</sup>q<sup>†</sup>t Kg<sup>†</sup> i AskM<sup>†</sup>h<sup>†</sup>Yi Dci tRvi  
t<sup>†</sup>lqv ntj KZE<sup>†</sup>q I Kg<sup>†</sup>fv t<sup>†</sup>ms<sup>†</sup>v<sup>†</sup>©l m<sup>†</sup>th<sup>†</sup>uMZvi ga<sup>†</sup> w<sup>†</sup>q A<sup>†</sup>tbK m<sup>†</sup>gm<sup>†</sup>v I 0<sup>†</sup>t<sup>†</sup>0i  
w<sup>†</sup>bimb NUvtZ cvti |

**uk<sup>†</sup>qv c<sup>†</sup>kvmtb gvbueK muK<sup>©</sup>ZtEj c<sup>†</sup>ve**

tivbv<sup>†</sup> Gd K<sup>†</sup>v<sup>†</sup>ut<sup>†</sup>et<sup>†</sup>ji gZ we<sup>†</sup>vj q c<sup>†</sup>kvmtb thme b<sup>†</sup>uZ<sup>†</sup>Z gvbueK muK<sup>©</sup>ZtEj  
c<sup>†</sup>Zdj b N<sup>†</sup>U<sup>†</sup>tQ Zv w<sup>†</sup>bg<sup>†</sup>efc:

- c<sup>†</sup>vb uk<sup>†</sup>qK/Aa<sup>†</sup>q DEg gvbueK muK<sup>©</sup>eRvq ti<sup>†</sup>L uk<sup>†</sup>qK<sup>†</sup>i mt\_ GKKf<sup>†</sup>ite  
Avj vc-Avtj vPbvi cikvc<sup>†</sup>mk m<sup>†</sup>we<sup>†</sup>sj Zf<sup>†</sup>tel Avj vc-Avtj vPbv Ki<sup>†</sup>teb|
- gvbueK muK<sup>©</sup>el<sup>†</sup>qK uk<sup>†</sup>Q<sup>†</sup>uK<sup>†</sup>Q<sup>†</sup>ym<sup>†</sup>gm<sup>†</sup>v i i<sup>†</sup>at<sup>†</sup>Z Z<sup>†</sup>Q etj g<sup>†</sup>tb ntj I cieZ<sup>†</sup>qZ ,ia<sup>†</sup>Zc<sup>†</sup>Y<sup>©</sup>  
ntq t<sup>†</sup> Lv t<sup>†</sup>q|
- c<sup>†</sup>vb uk<sup>†</sup>qK/Aa<sup>†</sup>q MYZ<sup>†</sup>ms<sup>†</sup>K tbZZj c<sup>†</sup>vtb Awak `wqZ<sup>†</sup>xyj n<sup>†</sup>teb, KviY Ab<sup>†</sup> i  
Z<sup>†</sup>z<sup>†</sup>bvq uZ<sup>†</sup>ub m<sup>†</sup>we<sup>†</sup>avRbK Ae<sup>†</sup>v<sup>†</sup>tb i<sup>†</sup>qt<sup>†</sup>Qb|
- uk<sup>†</sup>qKMY GK<sup>†</sup>u RuUj mvg<sup>†</sup>uRK `j weavq we<sup>†</sup>vj q c<sup>†</sup>vb<sup>†</sup>K mZK<sup>†</sup>ite Zvt<sup>†</sup>i mt\_  
Avj vc Avtj vPbv Ki<sup>†</sup>Z n<sup>†</sup>te|
- c<sup>†</sup>vb uk<sup>†</sup>qK/Aa<sup>†</sup>q uk<sup>†</sup>qKM<sup>†</sup>Yi g<sup>†</sup>ta<sup>†</sup> u<sup>†</sup>g<sup>†</sup> w<sup>†</sup>ev<sup>†</sup>i m<sup>†</sup>th<sup>†</sup>uM m<sup>†</sup>u<sup>†</sup> Kiteb hv<sup>†</sup>tZ uk<sup>†</sup>q<sup>†</sup>Yi  
t<sup>†</sup>q<sup>†</sup>t<sup>†</sup> m<sup>†</sup>te<sup>†</sup>PP m<sup>†</sup>qj cvl qv m<sup>†</sup>e<sup>†</sup> nq|
- th u<sup>†</sup>x<sup>†</sup>v<sup>†</sup>t<sup>†</sup>š<sup>†</sup>li c<sup>†</sup>ve thme uk<sup>†</sup>qK ev ÷vt<sup>†</sup>di Dci cot<sup>†</sup>e etj g<sup>†</sup>tb nq tmB u<sup>†</sup>x<sup>†</sup>v<sup>†</sup>š<sup>†</sup>u  
M<sup>†</sup>h<sup>†</sup>Yi t<sup>†</sup>q<sup>†</sup>t<sup>†</sup> Hme uk<sup>†</sup>qK ev ÷vd<sup>†</sup>t<sup>†</sup>K mu„<sup>3</sup> Ki<sup>†</sup>Z n<sup>†</sup>te|



### **gvbweK m#úK©ZtÉj gj`iqb**

10Zxq nekhtxi ci t\_tK gvbweK m#úK©ZtÉj Avte`b AtbKUl nvm tctZ \_vtK,  
 AvfthvM Dtv th GuU e`e`vcKt`i Kg©cwiPvj bvi GKUl tKŠkj Qrov Avi 1KQybq/  
 GZ`m#Éj gvbweK m#úK©ZÉj AvR Aewa GKUl ,iazcy©e`e`vcbv ZÉj intmte c#avb`  
 tctq AvmtQ| nekRto 1KŃv, e`emv I c#vmb LvZ c#Z ermi tKvU tKvU UvKv e`q  
 nt"Q gvbe m#úK©Dbqb m#úKŠ bvbv ai#bi c#KŃY KgŃP#Z| e`emvi tKŠkj intmte  
 bvbv ai#bi AevPvbK tKŠkj (Nonverbal Cues) thgb g,ynvm, `votŃcY BZ`v`i  
 e`envi, 1KŃtKi mvt\_ ue`vj tq c#avb 1KŃtKi KtŃ mvtŃvKvi Kivi e`tj AbvbŃvbK  
 cvi#t#k mvtŃv Kiv, Avctm AvZv\_tK tPqvi t\_tK Dtv `i Rvi Kv#Q 1Mtq AvgšY Rvbvtbv  
 BZ`v`i ci`úti c#Z m#yb I m#úKZteva RvM#Z ht\_ó mrvqK ntq \_vtK| Avgt`i  
 `bv`b Rv#b KgŃŃtĀ G ai#bi cvi#tek L#B `v`Ki I AvKv#LZ `evK|



**cv#VvEi gj`vqb: 4**

**A) eú ubePbx cĕœ**

m#WK DĒi ubt`Rgj-K Aŋiu#K eĚv#qZ Kiab| (D`vniY: Avcbvi ube#PZ DĒi#U K ntj G#K (K) eĚv#qZ Kiab)

1. wek kZvāxi cŭg w`#K cĕvmb I e`e`vcbvi Ab`Zg`enkó` #Qj tKvbiU?
  - K. Aa`b#`i Av`v I mn#hvMZvi Dci , iaZ; Av#ivc Kiv
  - L. `j xq c#Póvi Dci , iaZ; Av#ivc Kiv
  - M. Aa`b#`i K#Vvi fv#e ubqšY Kiv
  - N. Kvi Mix`bcY`#K D#cŋv Kiv|
  
2. n\_Y#ngxŋvi D#I`k` #Qj tKvbiU?
  - K. kĭgK#`i Kg#cwi#tek Dbz Kiv
  - L. kĭgK#`i Drm#n fvZv e#x Kiv
  - M. kĭgK#`i Drcv`b e#x Kiv
  - N. Drcv`b e#x i c#veK , t#v ubi#cy Kiv|
  
3. tKvbiU giv#eK m#úK#Z#Ēj c#v#ZMZ`enkó`?
  - K. Kg#cwi#tek MV#b Kg#`i AskM#Y
  - L. Av#b#vmbK `j mgn#K`gb ev #ej x#KiY
  - M. thvM#thvM`vc#bi tŋ#t# tM#vcbxqZv i ŋvKiY
  - N. mgn#v I #` ubi#b KZ#e#ŋi`v#qZ; M#Y|

**Av) msu#B DĒi cĕœ**

1. n\_Y#ngxŋv #K D#I`k` cwi P#vj Z ntq#Qj ?
2. Gj Ub tg#qv tKiv #el q , t#v#K tK>`aK#i M#el Yv K#i#Q#t# b?
3. Gj Ub tg#qvi M#el Yvq #K Z` D`NvUb ntq#Qj ?
4. giv#eK m#úK#Z#Ēj kĭgK ev Kg# f#gKv KZUKZ eY#v Kiab|
5. giv#eK m#úK#Z#Ēj K#qK#U c#v#ZMZ`enkó` D#t# K Kiab|



**m#WK DĒi**

A) 1| M, 2| N, 3| K|

**fvgKv**

Argiv Rmb, ckvmb gvTIB DfIk`gla Ges msMVbKw`K| j Q" I DfIk` AR#bi Rb`  
msMVibK Kvhfej i mgwi Pvj bvtK ckvmb ejv thZ cvti| evsj vt`tki mmeR ukQlv  
e`e`v GKUJ msMVibK KwVtgv AvI Zvq Mto DfVtQ| GQvor cU`igK, DcivbymbK,  
gva`igK I D"P gva`igK Ges Kvi Mvi ukQlv e`e`vi Rb` c`K c`K msMVibK KwVtgv  
itqtQ| eZgv BDibU evsj vt`tki gva`igK ukQlv tciZ ukQlv e`e`vi msMVibK  
KwVtgv m`utK`Avtj vPbv Kiv ntqtQ| BDibUitK tgvU wZbuU cvtV fVM Kiv ntqtQ| cU`g  
cvtV ukQlv gS`Yv q m`uik`Z Avtj vPbv `vb tctqtQ| wZxq cvVUitZ gva`igK I D"P ukQlv  
Awa`Bi Ges ZZxq cvtV AvAj K ukQlv cwi`Bi Ges tRj v ukQlv Avdm m`utK`Avtj vPbv  
Kiv ntqtQ|

- cvV- 1: ukQlv gS`Yv q: msMVb, `wqZ; Ges Kvhfej
- cvV- 2: gva`igK I D"P ukQlv Awa`Bi
- cvV- 3: AvAj K ukQlv cwi`Bi I tRj v ukQlv  
Avdmi `wqZ; Ges Kvhfej

**cW 1**

**ıkrıv gřıjy q: msMvb, `ıqZ; Ges Kıhıej**

**Dřıřk**

GB cıW řkřl Avırb—

- ř řki mıveř ıkrıv e`e`vi msMvbK Kvıřıvı Aıřb KırZ cıřeb;
- ıkrıv gřıjy řqi AiMıřbıMıg m`uřK`ej řZ Ges řevřıřZ cıřeb;
- ıkrıv gřıjy řqi `ıqZ;l Kıhıej eYřv KırZ l e`vL`v KırZ cıřeb Ges
- ıkrıv gřıjy q l Gi Avl Zvıxb msMvb`ıj i cıııPıřZ ı`řZ cıřeb|

**ıkrıv gřıjy q: msMvb**

ř řki mıveř ıkrıv e`e`vi mřeřP chıřq ıkrıv gřıjy řqi Ae`ıv| ıkrıv gřıjy řqi c`ıvb ıbeřıx nřjb ıkrıvgřı| ZıřK mıvıZv Křıb ıkrıv mıPe| ıkrıv gřı GKRb ıvR`bıZK e`ıřZı| Acıı řK ıkrıv mıPe nřjb c`kımıbK K`ıWřıı mřeřP chıřqi GKRb mıKvıx KgřZřř GQıvı ıkrıv gřıjy řq ıřqřQb GKRb Aıřıı<sup>3</sup> mıPe, ıZbRb hıMııPe, Qq Rb Dc-mıPe, řıv Rb mıKvıx mıPe Ges Ab`b` Kgřııe,`| ıkrıv gřıjy řqi mřıř msıřk` ıřqřQ GKıı cıı Kırıv řKıv | GB cıı Kırıv řKıv l i `ıqřZ; AvřQb GKRb c`ıvb, `řRb Dc-c`ıvb Ges `řRb mıKvıx c`ıvb| GQıvı ıřqřQb Ab`ıv` ÷vd| cıı Kırıv řKıv ıkrıv gřıjy řqi Aaxb` ıveřřbems`v KZř.tckKZ.Dbıb c`Kırımg n PıvřKırıı cı tııı gřıjy řqi Abřıv řbı e`e`v Křı| ersj vř`k b`ıvıvı Kıgkb dı BDřbř`v mřřřřc ıe.Gb.ım.BD bıvK c`řZıvııı ıkrıv gřıjy řqi Kvıřıvı mřıř hř| c`ıvıKvıej ıkrıvgřı GB c`řZıvııı řPqıvıvı Ges ıkrıv mıPe Gi gıvııPe| ıe.Gb.ım.BDı Aıřıı c`ıvıı c`ex nř`Q mıPe| GB c`řZıvııı BDřbř`v KZř MıřZ ıveřřbıKgřııP ev`ıvıb Křı| ıkrıv gřıjy řqi mıveř Kıhıejı Abııı ıvıııte Avı l ıřqřQ cıı kř l ıvııı ıbıxıvı cıı`Bı Ges d`ıvııııUR ıefıı| cıı kř l ıvııı ıbıxıvı Avı`Bıı c`ıvb `ıqZ; nř`Q řemiKııı ıkrıv c`řZıvııı řeZb fıvııı l Ab`ıv` LıřZ e`ıqZ mıKııı Ař`P mř`envı ıbııřZKıY| G Dřıřk` Avı`BıřK cıı křıbı `ıqZ; cıı b KırZ nq| ıkrıv gřıjy řqi Avl Zıvı ıveřřbııııvı c`řZıvıı ıbıgřı l mř`ıřıı `ıqZ; d`ıvııııUR ıefıřııı Dcı b`ıı|

**`ıqZ; Ges Kıhıej**

ř řki mıveř ıkrıv e`e`vi bııř ıbařK ıvıııte ıkrıv gřıjy řqi Ae`ıv| ıkrıv m`ıııKř ıveřřbıAvBb, ıeııa, c`ıeııa c`ıvı Ges Avř`k ıbř`R Rııı Kıv ıkrıv gřıjy řqi KvR| ıkrıvı mřıř m`ıııKř ıveřřbıAvřřřgřıjy q mřııřřııel qveııı ıb`ıııE Ges ř`LıřKıvıvı Kıvı ıkrıv gřıjy řqi Ab`Zg `ıqZ;|

ესჯტ`ტი უკვლცუმბ I ე`ე`ცბვი მუერ კვტგვ

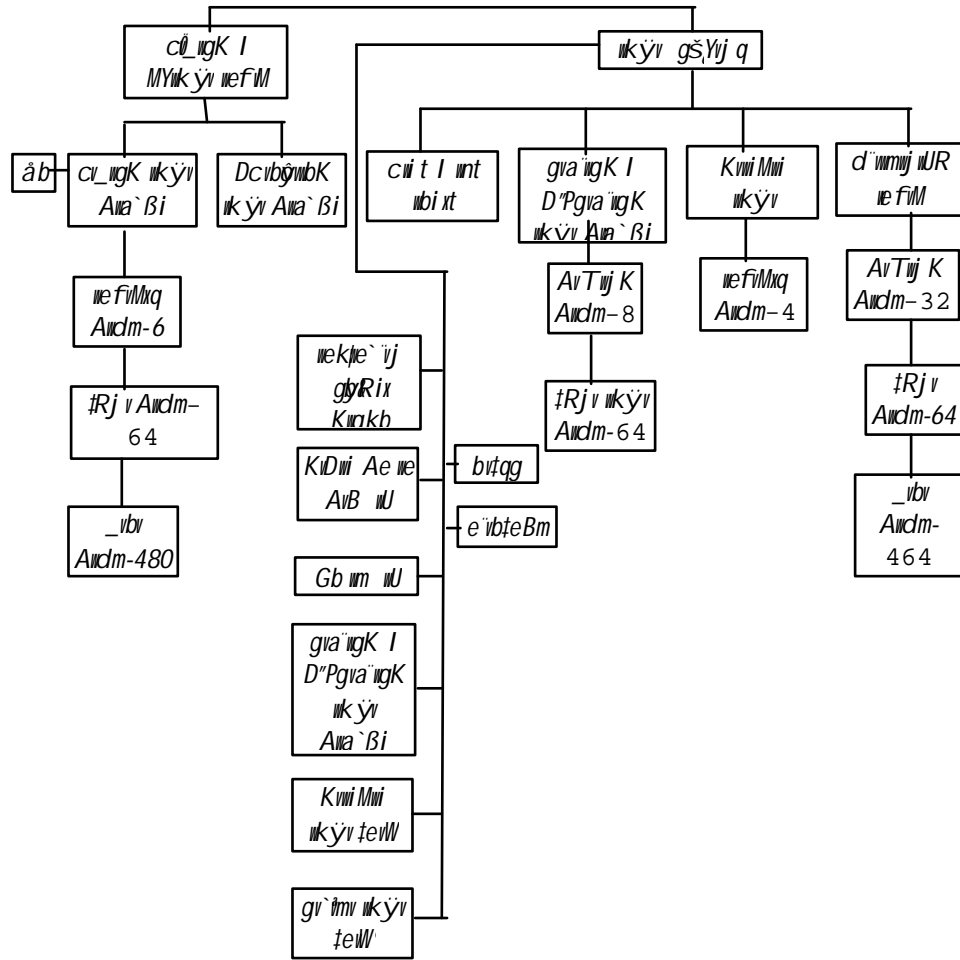

მსტ`ტ`ც უკ`ვლგს`ჲიჲ ტ`ი` `უიკ`Z; Ges K`i`h`e`ი`ჲ ჰ`K` უბგ`იჲ უL`Z`f`v`ტ`e` t``L`v`b`v` t`h`Z` c`v`t`i`:

1. ბ`მ`Z` უბა`წ`Y;
2. უკ`ვლ` მს`მ`u`š``ი`ე`w`f`b`e`A`v`B`b` c`l`q`b` Ges` ეე`w`e`e`a`v`b` R`v`i`;
3. t``ტი` მ`უ`e`R` უკ`ვლ`vi` R`b`` უკ`ვლ`b`m`Z` c`l`q`b` K`i`v`;
4. K``w`v`i` f`z` K`g`R`Z`e``i`` უბ`ტ`q`M`, e``j`x` I` c`f``v`b`e`Z` Ges` A`e`m`i` M`h`t`Y`i` P`p`v`š`i` A`b`g`v`i`Z` c`l`v`b`;
5. უკ`ვლ` მს`u`k`o` K`g`R`Z`e`I` K`g`P`v`i`t``i` t`e`Z`b`-f`v`i`Z`v`i` t``j`` უბა`წ`Y;
6. t`c`k`v`M`Z` D`b`q`t`b`i` j`ჰ`წ` უკ`ვლ`K` Ges` ეე`w`f`b`e`K`g`R`Z`e``i`` R`b`` t``ტი` I` ეე``ტი` c`l`k`v`t`Y`i` e``e``v` K`i`v`;

7. ukŕvi Dbq#bi j tŕŕi ũwfbaKugkb MVb;
8. Dbq#b cKí mg#ni Abŕgv`b I ev`evq#bi c`tŕŕc M#Y;
9. ukŕvi ũwfba`#i i Rb` ukŕvµg cŕq#bi bµZgvj v ũbaŕŕ Y Ges ukŕvµg ev`evq#bi j tŕŕi Avt`k, ũbt`R I mn#hµZv cŕvb;
10. D`P ukŕvi tŕŕtŕ eµE cŕv#bi e`e`v M#Y;
11. Aaxb` Awa`Bi, cwi`Bi Ges ms`vmg#ni Kvhpŕg Abŕgv`b Ges ev`evq#b mn#hµZv cŕvb;
12. RvZiq ukŕvi evtRU cŕqb (gŕŕvj tŕi Aaxb` ũwfbaAwa`Bi, ms`v I cŕZŕvb KZR.cŕxZ evtRU ukŕv gŕŕvj tŕi mfvq Avtj µPZ I Abŕgvµ Z nevi ci Poviŕ Abŕgv`#bi Rb` Zv A\_ gŕŕvj tŕ tŕŕY Kiv nq)|
13. ũbv`ŕ mgq Aŕŕi t`tŕki mµeR ukŕv e`e`vi Dbq#b I cµMŕ#bi Rb` Dŕ`vµ M#Y|

### AM#bulŕg

### ukŕv gŕŕvj q

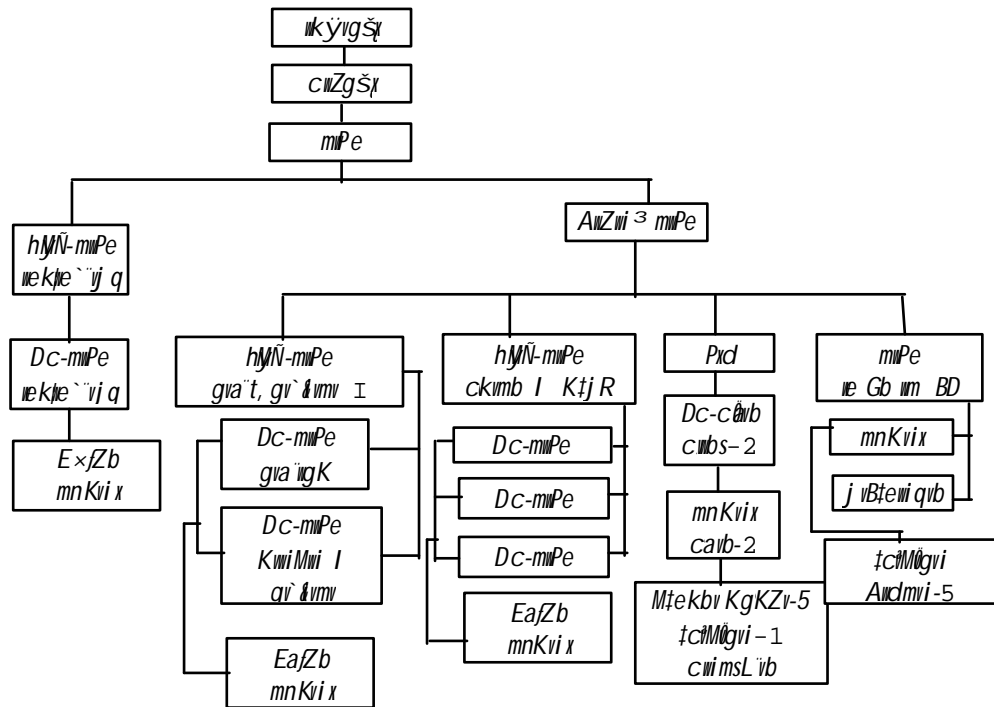



**cv#V#Ei gj`iqb: 1**

**A) e# ubePbx c#æ**

m#WK D#Ei ub#`Rgj-K A#i#U#K e#v#qZ Kiab| (D`vniY: Avcbvi ube#PZ D#Ei#U K ntj G#K (K) e#v#qZ Kiab)

1. uk#v g#y#j #qi c#vb ube#x tK?
  - K. iv#e#Z
  - L. c#vbg#x
  - M. uk#vg#x
  - N. uk#v m#Pe|
  
2. c#i`k# I #mve ubix#v A#`B#i i c#vb `v#qZ; tKv#U?
  - K. miK#i c#Z#vb, #j #Z e`v#qZ A#\_P m#`envi ub#DZKiY
  - L. temiK#i c#Z#vb, #j #Z e`v#qZ miK#i A#\_P m#`envi ub#DZKiY
  - M. temiK#i c#Z#vb, #j #Z e`v#qZ miK#i I temiK#i dv#Ui A#\_P m#`envi ub#DZKiY
  - N. c#i`k# Kv#m#v`b|

**Av) iPbv#j-K c#æ**

1. uk#v g#y#j #qi `v#qZ; Ges Kv#e#j D#j# Kiab| t`#ki m#e# uk#v e`e`vi Db#b I c#v#i Rb` G mKj `v#qZ; I Kv#e#j i tKv#Kg c#ieZ# I c#i gvR#bi c#qvRb Av#Q uk? Avcbvi m#v#Z gZv#Z e`<sup>3</sup> Kiab|



**m#WK D#Ei**

- A) 1| M, 2| L|

**cW 2**

**gva`ngK I D`PikŃv Ava`Bi**

**DŃk`**

GB cW tkŃl Avcib—

- gva`ngK I D`PikŃv Ava`BŃi mvsMvibK KvVtgv A¼b I eYŃv KiŃZ cviŃeb;
- gva`ngK I D`PikŃv Ava`BŃi Aaxb`wevfbaKvLvi `vqZj I KvHŃej m`uŃK`ej ŃZ cviŃeb Ges
- Ava`BŃi `vqZj Ges KvHŃej i Zvuj Kv cŃqb KiŃZ cviŃeb|

**msMvb**

gva`ngK I D`PikŃv Ava`BŃi mŃeP cŃ` itqŃb GKRB gnvŃv Pj K| vZvb Ava`BŃi cŃvb| gva`ngK I D`PikŃv Ava`Bi gva`ngK vKŃv, gv`Ńv vKŃv Ges KŃj R vKŃvi cŃvb I e`e`vcbvi mveR `vqZj vbtqvRZ| Ava`BŃi mvsMvibK KvVtgv tgvU cŃvU kvLv vbtq MvZ| kvLv, vj nj :

1. KŃj R I cŃvb kvLv|
2. gva`ngK vKŃv kvLv|
3. vŃv KŃv I Dbqb kvLv|
4. cŃvY kvLv|
5. kvvŃv K vKŃv kvLv|

KŃj R I cŃvb kvLv cŃvb nŃj b GKRB vŃv Pj K| ZvK mŃvZv Kivi Rb` itqŃb vZbRb Dc-vŃv Pj K, Pvi Rb mŃvŃv vŃv Pj K, Pvi Rb vKŃv Avdmvi, GKRB cŃvmbK KgRZP, GKRB vŃvŃvY KgRZP Ges Ab`vb` mŃvK ÷vd| KŃj R I cŃvb kvLv gj-Z miKvŃv KŃj ŃRi vKŃv i vbtqvM, e`v, c`vZ, Qv, tcbmb Ges temiKvŃv KŃj ŃRi vKŃv i Gg.vc.I fŃ i KŃj ŃRi `ŃvZ. cŃvb mŃvŃvŃv KŃv vŃv|

gva`ngK kvLv cŃvb vŃvŃv GKRB vŃv Pj K itqŃb| ZvK mŃvZv KŃv `Ńv Dc-vŃv Pj K, Pvi Rb mŃvŃv vŃv Pj K, Pvi Rb vKŃv Avdmvi Ges Ab`vb` mŃvK ÷vd| gva`ngK kvLv gva`ngK `Ńv i vKŃv i vbtqvM, e`v, c`vZ, AemiMŃv Ges temiKvŃv gva`ngK `Ńv i `ŃvZ. cŃvb I vKŃv i Gg.vc.I fŃ i KvŃv vbtqvRZ| GQvov gva`ngK kvLv gv`Ńv vKŃv i Gg.vc.I fŃ Ges gv`Ńv, vj i `ŃvZ. cŃvb KŃv vŃv|

vŃv KŃv I Dbqb kvLv cŃvb nŃj b GKRB vŃv Pj K| Zv Aaxb itqŃb GKRB Dc-vŃv Pj K, `Ńv mŃvŃv vŃv Pj K, `Ńv MŃvY Avdmvi Ges vKQymŃvK ÷vd|



ḡ Ae GW#Kkb

gnvcwi Pvj K mi Kvḡi th mKj cKḡi i ubeḡx cḡvb, GB kvLv gj-Z tmBme cKḡi ev ḡevqb mspvšKvR Kḡi ḡḡK|

kvixwi K ḡKḡv kvLvi cḡvb ntj b GKRb Dc-cwi Pvj K| ZḡK mnvqZv cḡvb Kḡi b ḡRb mnKvix cwi Pvj K, ḡRb μxov Avdmvi Ges GKRb MḡelYv KgRZḡ GB kvLv cḡvbZ ḡKḡv cḡZḡvb, ḡj i μxov I kixiPPP mspvš melq ḡḡLviḡv Kḡi Ges eml R Avšḡ ḡ μxov cḡZḡvMzvi AvḡqvRb Kḡi ḡḡK|

Avā ḡḡi i cKḡḡY kvLmU meḡcḡḡv bexb| GB kvLvi cḡvb ntj b GKRb cwi Pvj K| Zui Aaxḡb AvḡQb GKRb Dc-cwi Pvj K, GKRb mnKvix cwi Pvj K Ges GKRb MḡelYv KgRZḡ cKḡḡY kvLv ḡUPvmḡḡUḡbs Kḡj R Ges Abḡḡḡ ḡKḡv cḡZḡvb, ḡj i ḡKḡḡḡ i cKḡḡḡYi ḡ KḡU ḡḡLviḡv Kḡi |

### AMḡbMḡ

#### gvaḡK I DḡP ḡKḡv Avā ḡi

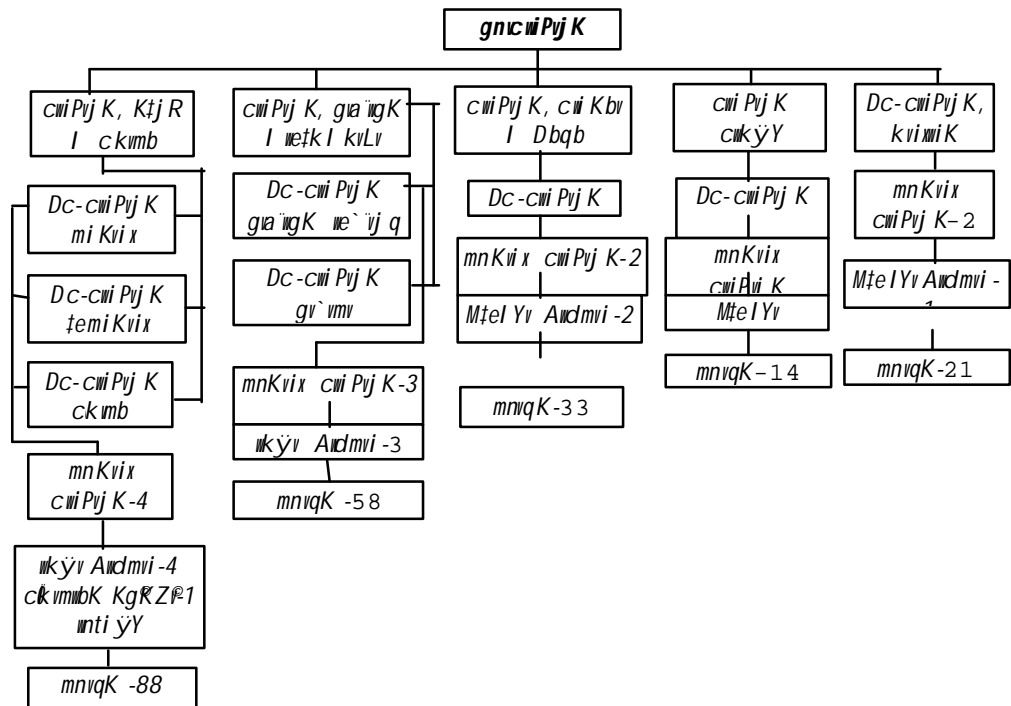

#### gvaḡK I DḡPḡKḡv Avā ḡḡi ḡḡZj Ges Kvḡḡḡ

ḡḡḡḡḡḡḡḡḡḡ gvaḡK I DḡPḡKḡv Avā ḡḡi ḡḡZj Ges Kvḡḡḡ Avḡj vPbv Kiv nj :

1. gvaḡK I DḡP gvaḡK ḡKḡv mspvšmi Kvixi bḡvZi ev ḡevqb;

2. ukʻv msvšbmvZ cŵqʻbi e`vcvʻi ukʻv gšYvj qʻK mrvqZv Kiv;
3. ukʻv cŵZŵvb,uj i GKvʻWwgK Kivʻeuj i e`vcbv I Z`vi uK;
4. temi Kvi ukʻv cŵZŵvb mi Kvi vbt`R ev`bvqʻbi cŵqvRbvq e`e`v MŵY;
5. Dbqb cKʻi i AvI Zvq mi Kvʻi i Dbqb KvʻRi Z`vi Kx;
6. mrvvi Y ukʻvi gvʻbvqʻb e`e`v MŵY;
7. t`tk Ges vett`k `q I Kʻj R ukʻvKʻ i cŵkʻʻYi e`e`v Kiv;
8. mi Kvʻi i vevfbvvefvʻMi mʻ½ thvMvʻthvM i vʻv Kiv;
9. ukʻv cŵZŵvb,uj i mKj KvRKʻgʻ mgšq mrvab Kiv;
10. mi Kvi ukʻv cŵZŵvb bZb tKvmʻelq cŵZʻbi Rb` AvZvi<sup>3</sup> c` mʻó Ges tfšZ mʻvav evx i c`ʻʻc MŵY;
11. temi Kvi ukʻv cŵZŵvb cvi Pij bvi Rb` AveZʻ gĀjx cŵvb;
12. temi Kvi ukʻv cŵZŵvb i ukʻvK/Kgʻvixʻ i teZb LvʻZ mi Kvi Abʻvb cŵvb;
13. bZb temi Kvi ukʻv cŵZŵvbʻK mi Kvi Abʻvb cŵvb i e`e`v;
14. ukʻv Ges ukʻv cŵZŵvb,uj i gvʻbvqʻb i jʻʻ cKʻi `Zvi;
15. Avā`Bivaxb Avdm/ukʻv cŵZŵvb i vR`^I Dbqb LvʻZi evʻRU cŵqb, e`q gĀjx I vrmvei vʻvʻ|



**ԸՆԴՀԱՆՈՒՐ ԳՆԱՀԱՆՈՒՄ: 2**

**A) ԵՍՈՒԹՅԱՆ ՄԱՍԻՆ ԱՊՐԱՆՈՒՄ**

մանկաձեռնարկի ղեկավարի պարտականությունները (Ընտրություն: Արժեքները ընտրելու համար հարցերի շարքում ընտրելու համար)

1. Գրականության մեջ Ընտրությունը մեծապես կհարստացնի ինչպիսիք կլինի այդ հարցերի լուծումը?
  - K. 3 լուծում
  - L. 4 լուծում
  - M. 5 լուծում
  - N. 2 լուծում
2. Ընտրությունը կհարստացնի Ընտրությունը գրականության կլինի այդ շրջանում?
  - K. գրականության ղեկավարի պարտականությունները
  - L. գրականության ղեկավարի պարտականությունները
  - M. ժամանակակից գրականության ղեկավարի պարտականությունները
  - N. ժամանակակից գրականության ղեկավարի պարտականությունները

**A) Ինչպիսիք է ընտրությունը**

1. Գրականության մեջ Ընտրությունը մեծապես կհարստացնի ինչպիսիք կլինի այդ հարցերի լուծումը?
  - K. գրականության ղեկավարի պարտականությունները
  - L. գրականության ղեկավարի պարտականությունները
  - M. ժամանակակից գրականության ղեկավարի պարտականությունները
  - N. ժամանակակից գրականության ղեկավարի պարտականությունները



**մանկաձեռնարկի**

- A) 1/ M, 2/ M/

**cW 3**

# **Av`ij K uk`lv cwi`Bi I tRjv uk`lv Avd`mi `wqZ; Ges Kvheij D`ik`**

GB cW tk`l Avcib—

- Av`ij K uk`lv cwi`Bi Ges tRjv uk`lv Avd`mi mvsMvibK ifctiLv c`vb Ki`Z cvi`teb Ges
- Av`ij K uk`lv cwi`Bi Ges tRjv uk`lv Avd`mi `wqZ; I Kvheij eY`v I e`vL`v Ki`Z cvi`teb|

## **Av`ij K uk`lv cwi`Bi: `wqZ; Ges KvR**

gva`ngK I D`Puk`lv Awa`B`ti Aax`b bqul Av`ij K cwi`Bi Av`Q| Av`ij K cwi`Bi ,ij XvKv, gqgbwmsn, P`EM`g, Kwj v, ivRkvn, iscj, Lj`bv, vmtj U Ges ewi kv`j Aew`Z| cwi`B`ti c`v`bi c`ex n`"Q Dc-cwi Pvj K A\_`P Dc-cwi Pvj K ntj b Av`ij K Avd`mi c`v`b| Zu`i Aax`b i`q`Qb GKRb ve`'ij q cwi`kR, GKRb ve`'ij q cwi`ukR, GKRb mnKvix ve`'ij q cwi`kR, GKRb mnKvix ve`'ij q cwi`ukR, GKRb mnvei`Y K gRZ`P I Ab`v` mnvqK ÷vd| Av`ij K uk`lv cwi`B`ti `wqZ; Ges Kvheij vbg`efc:

1. ve`'gvb veia veavb Abjvqx vbg`gva`ngK ve`'ij q `v`ctbi ce`v`gZ c`vb;
2. vbg`gva`ngK ve`'ij `qi GKv`WngK `xKwZ. c`v`bi Rb` ve`'ij q cwi`kR, cwi`kR c`Z`te`b gva`ngK I D`P uk`lv Awa`B`ti tc`Y Ges Awa`B`ti Ab`g`v`b M`h`Yi ci `xKwZ. c`vb;
3. EaY`Zb KZ`e`q`i vbt`k beg I `kg tk`Y tLjvi Ab`g`v`b c`v`bi Rb` uk`lv c`Z`v`b cwi`kR Ges Awa`Bi I tevW`eivei c`Z`te`b tc`Y;
4. EaY`Zb KZ`e`q`i vbt`k gva`ngK I D`P gva`ngK ve`'ij `qi `xKwZ. c`v`bi Rb` cwi`kR Ges c`Z`te`b msuk`v`B`ti c`vb;
5. veia Abjvqx vbg`gva`ngK ve`'ij `qi `xKwZ. bevq`bi e`e`v M`h`Y;
6. veia Abjvqx gva`ngK ve`'ij q I `vLj gv`v`mvi g`v`b`Rs Kvgu`i ve`'vbjv`Mx m`m` g`b`v`bq;
7. vbg`gva`ngK ve`'ij `qi Gv`nK/vbq`gZ g`v`b`Rs Kvgu`i Ab`g`v`b;
8. tRjv uk`lv Avd`mi Kv`Ri Z`vi Kx;
9. msuk`v` AA`tj i vbg`gva`ngK I gva`ngK ch`q`i uk`lv c`Z`v`bmg`ni uk`lv , YMZ gv`b Db`q`k`f` c`q`v`Rb`q Kv`h`e`g M`h`Y;





**cı#VvEi gj`ıqb: 3**

**A) eü ıbeıPbx cıkæ**

mı#K DËi ıbt`Rgj-K AŋııU#K eĖııqZ Kiab| (D`vniY: Avcbri ıbeıPZ DËiıU K ntj G#K (K) eĖııqZ Kiab)

1. t`tk KquU AvÂıj K ıkŋıv cwi`Bi Av#Q?  
 K. 5 ıU  
 L. 6 ıU  
 M. 7 ıU  
 N. 9 ıU|
  
2. ıbt#Pi tKıvıU gj-Z tRjv ıkŋıv Aıd#mi `ııqZı?  
 K. ıbgæıva`ıgK ıe`ıj tqi `ıKıZ. cÜvb  
 L. ıbgæıva`ıgK ıe`ıj tqi `ıKıZ. beıqb  
 M. `ıDU I MıBW Kvhıtg gŞııj tqi ıbt`Rmgı-er`evqb cwi exŋıY  
 N. gv`ııvıv ıkŋıK#i Gıııı fıe#|

**Aı) iPııgj-K cıkæ**

1. mstŋı#c tRjv ıkŋıv Aıd#mi `ııqZı I Kvhıııj eYıv Kiab| G mKj `ııqZı cıj#bi tŋı#ı tRjv ıkŋıv Aıd#mi KZU#z`ıaxbZv i#q#Q? Avcbri gZıgZ ıj Lı|



**mı#K DËi**

A) 1| N, 2| M|



cW 1

**KgP'e'e`'lcbvi A\_©, iaZ;I cÖZövtbi**

**Dt'ik"**

GB cW tk'tl Avcib—

- KgP'e'e`'lcbv ej tZ wk tevSvq Zv weeZ Ki tZ cvi teb Ges
- cÖZövtbi j`'l I Dt'ik" ARfb KgP'e'e`'lcbvi , iaZ;e`'vL`v Ki tZ cvi teb|

**KgP'e'e`'lcbvi A\_©**

h\_vh\_ ubt`R, cwi Prj bv I ubqstYi gva'tg cÖZövtbi KgP'e`'tK `^`^`vncZ; cij tB DrmwnZ Kiv tK KgP'e'e`'lcbv ejv th tZ cvi t| GKRb cÖvmK ev e'e`'lcbv ubt`R hLb KgP'e`'i g'tS c'fve tKi KvR Kti, ZLbB Zvt`i gvtS tcl Yv m'p I Kg'öüpv RvM'Z nq| Kiv RB ejv hvq, ubt`R cÖvtbi , ymz `euk'tó'i Dci msMvb Z\_v KgP'e`'i Kg'ö Zrci Zv wfb'P Kti |

wk'lv cÖvm tbi t'q't' gvbexq m'ú` kãw AwaKZi Zvrch'öenb Kti | Kvi Y wk'lv cÖZövtbi hveZiq Kvhe'ij B g'vbe m'st'bi DbwZi j t'q' ubte'w Z| wk'lv cÖZövb msuk'ö e'w<sup>3</sup>e'tM'p gvtS Dch'ö ubt`Rbv, tcl Yv I KgZrci Zv m'p'öi gva'tg wk'lv cÖZövb Z\_v wk'lv Dbaq wk'lv t'q't' KgP'e'e`'lcbvi Ab'Zg j`'l|

“Human management includes the employment of suitable persons with adequate motivation to put in their best, living up of the payment of their salaries, providing of in-service training, formulating policies and methods to unite the entire body of workers in an attitude of enthusiasm to achieve the best possible results.<sup>1</sup>”

Bsti wR Ab'j'Q` w t` tK KgP'e'e`'lcbvi Ktqkw w `euk'ó` j`'l Kiv th tZ cvi t:

1. ch'ß tcl Yv m'p'j Z Dch'ö KgP'ubt'q'wM hviv h\_vm'æe k'g`vb ev Kg'öüv` tB Dsgy;
2. KgP'e`'i cwi k'gK ev teZb cÖvtbi h\_vh\_ e'e`'v M'h'Y;
3. KgR'v'j xb c'k'q't'Yi e'e`'v;
4. m'te'Ëg dj jvt'fi j t'q' KgP'e`'tK D'ixc'v'g'j-K` w'p'f'w'z mnKv'ti GKw'Z Kiv Ges GRb` h\_vh\_ b'wZ I c'x'wZ c'v'q'b Kiv |

Gkw wk'lv cÖZövtbi KgP'e'e`'lcbvi Avl Zvq wk'lv\_Ë, wk'lvK Ges Ab'vb` m'nvqK ÷ vt'cdi b'v'g D't'j L Kiv hvq| Gt` i tK wN't'i B wk'lv cÖZövtbi hveZiq KgP'e`'v'v AvenZ'Z |

<sup>1</sup> L.I. Gupta, Educational Administration, P-68.



## Kg#e'e'vcbvi , iaZ;

Av#MB ejv n#q#Q Kg#e'e'vcbr ej#Z Ggb GK#U e'e'vcbr#K tevSvq hv c#Z#v#bi Kg#e' i g#S-

(K) tc#Yv m#p# K#i

(L) Drm#n I D#i#cbv m#p# K#i Ges

(M) Kg#e'v#n RvM#Z K#i A\_#|

Kg#e' #K c#Z#v#bi Db#b Ges j # AR#bi Ab#Zg n#v#Zqv# n#m#e' #Z#i K#i |

c#Z#v#bi m`m` n#m#e' GKRb e'v#i `# m#Ej j # Kiv hvq| GK#U Zvi e'v# m#Ej, Ac#U `j#q m#Ej| D#Eg Kg#e'e'vcbrq GKRb c#Z#v#b c#v#b e'v#i GB D#f#q m#Ej#i c#Z# mgvb , iaZ;#`b| Kv#RB GK# #K #hgb e'v#i P#v#`v c#Y nq, #Zg#b `#j i P#v#`v#l c#Y nq| G `#i m#z#ng#q# c#Z#v#b#K j # AR#K Z#i v#S#Z K#i |

m#M#v#b gv#T#B `# c#v#g#Uj #e#v#R K#i| GK#U c#Z#v#b#K c#v#g#Uj, Ac#U e'v#M#Z c#v#g#Uj | c#Z#v#b#K c#v#g#Uj# i#q#Q c#Z#v#b, #v#g#K#v Ges c#Z#v#k#v| #v#g#K#v #v#v# #v#g#K#v Av#K#v#x e'v#i Av#P#i#Y#K tevSvq| A\_# e'v# th #v#g#K#v ev c#` i#q#Q, tm c` ev #v#g#K#v m#v#k#b Av#P#i#Y#i ga` #`#q #v#g#K#v i#f# c#v#`v# n#`Q| G Q#v#v# c#Z#U# #v#g#K#v m#`# #K#Q#y `v#q`#v#q#Z#;ev ev#eva#K#Z#v\_#v#K#| G #j #K ejv hvq c#Z#v#k#v| e'v# #b#R #b#R #v#g#K#v c#v#j#b#i ga` #`#q GB c#Z#v#k#v c#Y K#i \_#v#K#| GB c#Z#v#k#v #v#ea- c#Z#v#b#K c#Z#v#k#v Ges e'v#M#Z c#Z#v#k#v| e'v#M#Z c#v#g#Uj# i#q#Q e'v# #b#R, Zvi e'v#M#Z P#v#`v Ges Zvi e'v#Z#j| t#M#U#R#j#m Gi g#Z e'v#i P#v#`v c#Y#i #b#R`^#a#b I c#v#v#k#R#Z#v#i c#Z# Zvi c#Z#v#q#v#B n#`Q e'v#Z#j| c#Z#v#b#K c#v#g#Uj Ges e'v#M#Z c#v#g#Uj m#h#v#M#v#`#j#q ev #k#v#v# c#Z#v#b#v#g#K#v#m#g#v#R#K #m#`#g# M#o I #v#| #k#v#v# c#Z#v#b#v#g#K#v#m#g#v#R#K #m#`#g#i Av#l Z#v#q th m#K#j e'v#e#M#ev Kg#e' i#q#Q, Z#v#`i e'v#Z#; P#v#`v, c#Z#v#k#v Ges #v#g#K#v c#v#`v#b I Kv#R#i ev`#v#q#b m#z#Kg#e'e'vcbvi g#v#`g# A\_#n n#q I #v#| GKRb Av#F#A #k#v#v# c#k#v#m#K #b#R Av#P#i#Y#K #b#q#S#Y# K#i#b, m#j#K#S#k#j #b#`R# c#v#v#bi ga` #`#q c#Z#v#b#i m`m` Z\_#v Kg#e' i g#S# tc#Y#v I Kg#e'v#n RvM#Z K#i#b Ges c#Z#v#b#K C#v#Z# j # AR#bi #`#K G#M#q# #b#q# hv#b|



**cvVĚi gj`vqb: 1**

**A) eü ubePbx cĕæ**

mĭWK DĚi ũbt` Rgj-K AŋiŭK eĚvqZ Kiab | (D`vniY: Avcbvi ũbePZ DĚiŭ K ntj GĕK (K) eĚvqZ Kiab)

1. DĚg KgP e`e`rcbvi `enkó` tKŭbŭ?
  - K. ũbt` Rbv I ũbqšY
  - L. ũbt` Rbv I cĕveb
  - M. cŭi Pvj b I ũbqšY
  - N. cŭi Pvj b I Avt` k cŭvb |
  
2. GKŭ cŭZŏvbi Kgĕt` i KgZrciZv ũKtmi Dci ũbF P Kti?
  - K. cŭZŏvb cŭvĕbi eyx I Kĕj Zvi Dci
  - L. cŭZŏvb cŭvĕbi KgZrciZvi Dci
  - M. Kgĕt` i `ŋZvi Dci
  - N. ũbt` R cŭvĕbi ŭYZ `enkó`i Dci |
  
3. ũbt`Pi tKvb Kvrŭŭ cŭZŏvbK j ŋ` ARĕb mnvqK?
  - K. e`ir<sup>3</sup>i Pvn`v ci-Y
  - L. `j xq Pvn`v ci-Y
  - M. e`ir<sup>3</sup>MZ I `j xq Pvn`vi mgšĕ
  - N. cŭZŏvb cŭvĕbi e`ir<sup>3</sup>MZ `enkó` |

**Av) iPbvj-K cĕæ**

1. KgP e`e`rcbvi ŭiaZj I cŭqvRbxqZv Dtj LceR DĚg KgP e`e`rcbvi `enkó`mĕ Ztj aiab |



**mĭWK DĚi**

A) 1 | K, 2 | N, 3 | L |



mst`qtc ejv hvq, we`'ij tqi fuZ`cxwZ GKUW mybw`'b bmxZgyjv Ges weAvbma`S I MYZmwšK cxwZtZ nlqv evAbxq| tkWYKt`qi eü wk`qv\_`f gvtS mevi cÖZ mgvb bRi t`lqv wk`qKt`Ki c`f`q m`e bq| wk`qv\_`f`i`K weifbæ`qz`'qz`'tj fVW Kt`i GK GKRb wk`qKt`Ki Avl Zvq b`v`l`Ki`ij wk`qK-QvT m`u`tk`P w`fZ `p nq| i`ayZvB bq| MÆc weifbæ cÖZfv I gb-gvb`tmi wk`qv\_`f`i`Rb` GKUW AwZ DEg w`gjb t`qT`| GKv`Ww`gK Ges bb-GKv`Ww`gK Dfq t`qT`i w`bq`gZ gj`v`q`bi e`e`v wk`qv\_`f`i`K mRvM I mZK`ivLte| KviY Zviv Rvbte th, wk`qKt`i m`v RvM`Z `w`p Zvt`i Dci w`bex| wk`qK-Aw`f`v`eK m`u`tk`P mef`c`qv KvhRi w`K nt`Q GuU wk`qv\_`f`i` w`b`Rbv Kv`f`Ri Rb` AZ`šI Dc`thwMx|

**wk`qK e`e`v`cbv**

wk`qv cÖvm`tbi mef`c`qv bvrK` w`K nt`Q wk`qK e`e`v`cbv| GLv`tbB wk`qv cÖvm`tbi m`t`/ Ab`vb` cÖvm`tbi `y`li e`eavb i`q`q`Q| GKRb we`'ij q cÖv`tbi Aax`tb Ggb me wk`qK \_v`f`Kb huiv Avb I cvi`wk`Zvq Zui mgK`q| G mKj wk`qKt`K Av`k w`b`R cÖv`tbi t`qT`i ht`ó mveavbZv ev mZK`Zv Aej`w`b Kiv evAbxq| ". . . The zone of acceptance, that is the uncritical adoption of rules and orders from superiors, is much narrower in the case of college teachers than in the case of other types of employees. Procedures and means of communication with the teachers therefore will be different from those of other personnel."<sup>3</sup> GLv`tb Kt`j`f`Ri wk`qKt`i w`el`q hv ejv nt`q`q`Q, Zv me `f`ii wk`qKt`i t`qT`i`B cÖhvR`| wk`qK I cÖZ`övb cÖv`tbi m`u`K`Two Way Traffic Gi gZ| cÖZ`övb cÖvb wk`qKt`i`K gh`v w`teb| Zv`i`K w`ek`m Kiteb| w`K t`Z`g`v`f`v`te wk`qKMYI Zv`i` cÖZ`övb cÖv`tbi Dci Av`v ivL`teb, Zv`K m`š`b Kiteb| Dfq Zid t`\_`f`K Av`v I m`š`t`bi Afve AtnZK` f`z e`š`v`v`S Ges D`f`OM I DrK`Évi Rb`f`t`q hv cÖvm`t`K w`ech`i`Ki`t`Z eva`|

**mnvqK ÷vd e`e`v`cbv**

wk`qv cÖZ`övb`i mnvqK ÷v`tdi g`ta` hviv i`q`q`Qb, Zviv nt`j`b:

- (K) **Avdm ÷vd-** cÖvb mnKvix, D`Pgyb mnKvix, wbggyb mnKvix, wmw`ei`q`K, UvBw`c`ó cÖ`E`|
- (L) **QvT`vevm ÷vd-** Z`É`y`eavqK, mnKvix Z`É`y`eavqK, ev`v`P`MvW`m`B`cvi, Avqv cÖ`E`|
- (M) **Gg.Gj.Gm.Gm-** `v`i`v`q`v, gw`ij, m`B`cvi |
- (N) **Ab`vb`-** wk`qv cÖZ`övb, t`j`v`t`Z A`b`K mgq N`É`v ev `w`b`K w`f`v`É`t`Z ivR`v`g`-x, Kv`v`v`g`-x, w`bgR`j`x, B`t`j`Kv`U`K w`g`-x c`f`v`Z. Kg`f`e`x` KvR Kt`i \_v`f`Kb|

mnvqK ÷vd`i e`e`v`cbvi t`qT`i w`b`w`ij w`LZ w`el`q`\_`w`ij i` cÖZ `w`öcvZ Kiv cÖ`qv`Rb:

- cÖZ`w` M`æ`ci ÷v`tdi Rb` Kv`f`Ri mybw`'b bmxZgyjv \_v`K`t`Z nte|
- th th Kv`f`Ri Rb` Aw`K`Zi Dch`š, Zv`f`K tm Kv`f`Ri `w`q`Z`i`w`t`Z nte|
- w`bq`gZ KvR Z`É`y`eav`t`bi e`e`v`\_v`K`t`Z nte|

<sup>3</sup> L.D. Gupta, Educational Administration, P-70.

ᚦ Ae GW#Kkb

- cōZiU ÷vtdi KivRi h\_vh\_ gj`vq̄bi e`e`v`\_vKtZ nte|
- mevi Rb` KgZwiBi e`e`v`\_vKtZ nte| KivR Avb` KivRi , YMZgvb ewx̄tZ mnvqZv Kti |

we`ij q cōv̄bi c̄f̄ memgq mevi KivR ZĒyeavb Kiv mæ bvl n̄Z c̄v̄i | DĒg nq hw̄ PZz̄<sup>o</sup>tk̄Yi KgPvix̄`i ZĒyeav̄bi `v̄qZvU tKvb Dch̄<sup>o</sup> uk̄<sup>o</sup>̄t̄Ki Dci b`v`i Kiv hvq| cōZiU ev cōZ M̄t̄ci KgPvix̄i Rb` KgZv̄j Kiv ev Job Description `Zwi K̄ti Zv̄`i t̄K AeinZ Kiv t̄M̄j KgP̄e`e`v̄cbvi KivR Āt̄bK mnR nq| GQvov cōZōv̄bi Kḡm̄ūv`̄bi Rb` m̄ybw̄<sup>o</sup> mgq v̄bNĒ `Zwi Kiv c̄q̄vRb|



## c̄v̄VĒi gj`vq̄b: 2

### A) eū v̄bePbx c̄k̄æ

m̄iWK DĒi v̄b̄t` Rgj-K Āq̄iŪt̄K eĒv̄qZ Kiab| (D`v̄niY: Avcbvi v̄beP̄Z DĒiU K ntj Ḡt̄K (K) eĒv̄qZ Kiab)

1. uk̄<sup>o</sup>̄v̄\_̄P̄e`e`v̄cbvq uk̄<sup>o</sup>̄v̄\_̄P̄`i Rb` A`k` uk̄<sup>o</sup>̄v̄<sub>v̄</sub>g `Zwi i D̄m̄ t̄Kiv̄iU?  
K. t̄k̄<sup>o</sup>̄YK̄<sup>o</sup>  
L. M̄š̄v̄M̄vi  
M. t̄L̄j vi gv̄V  
N. we`ij t̄qi m̄v̄eR̄ c̄v̄i t̄ek |
2. uk̄<sup>o</sup>̄K-Av̄f̄v̄eK m̄ū̄t̄K̄P̄ meĒc̄<sup>o</sup>̄v̄ Kvh̄R̄i v̄`K t̄Kiv̄iU?  
K. ḠiU uk̄<sup>o</sup>̄K̄ I Av̄f̄v̄eK̄`i ḡt̄a` D̄m̄v̄t̄ni m̄Āvi K̄ti  
L. uk̄<sup>o</sup>̄v̄\_̄P̄`i AM̄v̄Z Z̄i v̄š̄Z K̄ti  
M. uk̄<sup>o</sup>̄v̄\_̄P̄`i v̄b̄t` R̄bv KivR mnvqZv Kti  
N. uk̄<sup>o</sup>̄K̄`i ḡt̄a` m̄t̄P̄ZbZv m̄ȳo K̄ti |
3. c̄v̄v̄b uk̄<sup>o</sup>̄K Ges Ab`v̄b` uk̄<sup>o</sup>̄K̄`i ḡv̄t̄S uk̄<sup>o</sup>̄i f̄c m̄ū̄K̄<sup>o</sup>̄I qv̄ ev̄Āb̄v̄q?  
K. eŪž gZ  
L. GKZidv̄  
M. Df̄q Zidv̄  
N. Dj̄<sup>o</sup> m̄ū̄K̄<sup>o</sup>

### Av) i P̄b̄v̄q̄j-K c̄k̄æ

1. t̄Kb uk̄<sup>o</sup>̄v̄\_̄P̄K cōZōv̄bi meĒc̄<sup>o</sup>̄v̄ gj`evb m̄ū̄` ejv nq? uk̄<sup>o</sup>̄v̄\_̄P̄e`e`v̄cbvi t̄q̄t̄i c̄v̄v̄b uk̄<sup>o</sup>̄t̄Ki `v̄qZv̄eij v̄ēt̄k̄<sup>o</sup>̄Y Kiab|
2. uk̄<sup>o</sup>̄K e`e`v̄cbv̄t̄K t̄Kb c̄k̄v̄m̄t̄bi meĒc̄<sup>o</sup>̄v̄ bv̄R̄k̄ v̄`K ejv nq? uk̄<sup>o</sup>̄K e`e`v̄cbvi v̄ēv̄f̄b̄v̄ K m̄ū̄t̄K̄Av̄t̄j v̄P̄v̄ Kiab|
3. mnvqK ÷vd̄t̄`i e`e`v̄cbvi t̄q̄t̄i t̄Kiv t̄Kiv v̄ēt̄t̄qi cōZ `v̄ōcv̄Z Kiv c̄q̄vRb?



## m̄iWK DĒi

A) 1| N, 2| M, 3| M|

**cW 3**

**Kgpe`e`lcbvi nuzqvi I tKskj**

**Df`k`**

GB cW tkfI Avcib—

- Kgppe`e`lcbvi tKskj I nuzqvi m`utK`ej tZ cvi`teb Ges
- GKRb uk`qv c`kvmK uk`fvte nuzqvi ,uj e`envi Ki`teb Zv e`vL`v Ki`tZ cvi`teb|

ce`ZP`cvtV uk`qv`e, uk`qK Ges mnvqK ÷vd e`e`lcbv m`utK`Avtj vPbv Kiv ntqtQ| GB Avtj vPbv t`tK m`yúó tevSv hvq th, Kgppe`e`lcbv Kv`h`m`áúv`tbi Rb` GKRb c`Z`óvb c`ávb`tk Aek`B `t`k`P`I Avf`Á ntZ nte| thb`tZb fvte uzub e`e`lcbv Kv`h` mgvav Ki`tZ cvti b bv| Z`tk Aek`B m`bwi`e uk`Qy`Kskj I nuzqvi e`envi Ki`tZ nte|

1. Avgiv Rmb e`e`lcbvi Ab`Zg j`q`nj - To get the best man and to get best out of that best man. ev`leKc`f`q MYZm`šK Ges gv` mgvR e`e`lq c`Z`uU gv`b`j`i`B Zvi e`w`m`E`y Ges thvM`Zv I `q`Zvi m`te`P`P m`xgvq tc`ú`veri Av`kvi itqtQ| GK`uU uk`qv c`Z`óv`tbi Kgppe`e` Zv`i `^`^`c`Z`fvi tkl m`xgvq tc`ú`veri Rb` KZU`K`z`m`š`h`vM m`y`av cvt`Q Zvi Dci c`Z`óv`u`i Dch`y`Zv w`bf`P` Kti | Avtj vPbv t`tK `ú`óZ tevSv hvq, evni t`tK Prc c`q`vM Kti bq, eis c`Z`uU Kgp`K `Zt`ú`Z`f`vte w`R w`R thvM`Zv e`x`i m`š`h`vM Kti w`tZ nte| G`uU ZL`bB m`e` hL`b Kt`g`P` cvit`ek` nq Avb`>`v`q`K I Drm`vne`Á`K| GB cvit`ek` `Zvi i `v`q`Zi c`Z`óvb c`ávb`ti | Kgp`e` i`tK KvR Kivi `x`b`Zv w`tZ nte|

2. uk`qv c`kvm`tki Rb` hv Aek` c`q`vR`b`q Zv nj :

- (K) m`y`i , w`bg`P` gv`b`e`K m`ú`K`P` Z`tk GB gv`b`e`K m`ú`K`P` gb`E`j Rv`b`tZ nte|
- (L) `Zt`ú`Z`f`vte Kgp`m`áúv`tbi t`q`t`I tc`ú`Yvi , i`áZi m`ú`K`P`Z`tk I qv`K`d`n`v`j `v`K`tZ nte| A`\_`P` uzub Zvi mnKgp`e` i w`f`Zi Kv`t`Ri tc`ú`Yv m`y`o Ki`teb|
- (M) Z`tk MYZm`šK i`m`Z c`x`u`Z Ab`y`i`Y Ki`tZ nte|
- (N) Kgp`e` i w`f`Zi Av`Z`f`D`b`q`t`bi mei Kgp`m`š`h`vM m`y`av uzub m`y`o Ki`teb|

3. Z`tk gtb ivL`tZ nte t`Kej gv`I KZ ,uj Av`Bb Kv`b`y` c`q`vM Ki`t`j`B fvj dj Avkv Kiv hvq bv| Gi Rb` c`q`vR`b` m`y`i gv`b`e`K m`ú`K`P`v`cb| Kv`t`RB, c`Z`óvb c`ávb`tk `Av`f`k` c`ú`vb I Av`f`k` cij b`ú` b`m`Z cv`i`n`vi Kti m`y` , w`bg`P` gv`b`e`K m`ú`K`P`v`cb`i w`tK b`Ri w`tZ nte| uk`qv h`w` mgvR cvieZ`f`bi nuzqvi nq, Zvntj Kgppe`e` t`K Aek`e` `ij`q` Z`\_`v uk`qv c`Z`óv`tbi m`t`½ GKv`Z`f` ntZ nte| c`Z`óvb c`ávb Ges Kgppe`e` i gv`f`S m`y`m`ú`K`P` e`Ü`bB t`Kej GB GKv`Z`f`v m`y`o Ki`tZ cvti |

4. m`y`Z`Kgppe`e`lcbvi Ab`Zg nuzqvi nt`Q MYZm`šK i`m`Z c`x`u`Z I `w`ó`f`w`½| MYZm`šK `w`ó`f`w`½ m`ú`b`e`GKRb c`kvmK t`Kej c`kvm`KB bb, GKRb t`b`Z`vI e`f`U| mevi c`Z`

mgvb ᄡ Ges thwM`Zvbnvqx mnKgf`i gvtS `vqZ; eEb I mthwM mjev cŃvb MYZvšK cŃvmtKi Ab`Zg `ewkó| wbtRi gZvqZ Atb`i Dci Prcvbtv bq, eis mevi gZvgtZi wfvÉtZ wmvšl I KvhŃg MhY, mnKgf`i cŃZ cŃZŃvb cŃvbtbi mŃŃbtvŃtai cwiPq enb Kti| MYZvšK cwiŃtek cŃZŃvbtbi mŃZKgf`e`e`rcvri mnvqK| MYZvšK cwiŃtek w`vj q cŃvb KZŃ; I ŃlgZv mnKgf`i mŃ½ fIM Kti tbb| hvŃK `vqZ; t`l qv nq, ZvtK `vqZ; cvj tbi DcŃhwMx KZŃ; Ges ŃlgZv cŃvb Kiv nq|

5. mŃZKgf`e`e`rcvri Rb` cŃZŃvb cŃvb Ges Zui mnKgf`i gvtS mŃvúK`thgb , iŃZŃY`tZgub mnKgf`i ci`úti gvtS mŃvúK`Ges mŃŃbtvŃtal mgvb , iŃZŃY` mnKgf`i ci`úti gta` 00 I wŃvta cŃZŃvbtbi KvhŃgtK e`vnZ Kti| GB 00-wŃvta GovtŃvri Ab`Zg Dcvq cŃZŃvbtbi mŃMVwbK KivvŃgvi mŃúŃ wŃv`m Ges cŃZw Kgf` `vqZ; I fvgKvi h\_vh\_ e`vL`v| A\_Ń cŃZŃvbtbi m`m`i gta` AvštmúK` Ges KZŃ; i`li wbaŃY| KZŃ; i GB `li wbaŃYtK c`Ńmvcvbl ejv hvq| `li wfvÉK c`Ńmvcvbl 0viv mŃMVtbi `vqZ; Ges KvhŃwŃj AZ`šl mŃ;Lj fvŃe cvwŃj Z nŃZ cŃv|

6. KZŃ; i`li wbaŃYtYi mŃ½ wŃqšŃYi cŃvri mivmwi mŃúwKZ| cŃZŃvb cŃvb meŃq ŃlgZvi AwKvix ntj I Zui cŃŃ GKv cŃZŃvbtbi me KgPvixtK mivmwi wŃqšŃ Kiv mŃe nq bv| ZŃK GB `vqZ; Aaxb`w mŃwŃqj wKQyKgŃŃŃ wŃKU AcŃ KiŃZ nq| tmB mŃ½ GKRB KgŃZP KZRb KgPvixtK wŃqšŃ Kiteb Zvi GKw w K wbt`Rbv \_vKv cŃqvRb| Gw wfvŃ Kti cŃZŃvb cŃvbtbi KvŃRi cwiŃvc I aib Ges Kgf`i thwM`Zv I AwfÁZvi Dci| KvŃRB t`Lv hvŃ`Q th, DĚg KgŃe`e`rcvri Rb`-

7. cŃZŃvbtbi mKj KgŃZP I KgPvixi gta` `vqZ; I ŃlgZvi mŃwŃ 0 eEb GKvšl cŃqvRb| `vqZ; I KZŃe`i GB mŃwŃ 0 eEb cŃZŃvbtbi KvhŃwŃj mŃZvŃte mŃv`tb mnvqK|



**cv#VĚi gj`vqb: 3**

**A) eû ubePbx cĭæ**

m#WK DĚi ubt`Rgj-K AŋiuU#K eĚv#qZ Kiab| (D`vniY: Avcbvi ube#PZ DĚi#U K ntj G#K (K) eĚv#qZ Kiab)

1. Kgf`i Rb` Avb>`vqK I Drmine`ÄK Kv#Ri cwi tek m#oi j#ŋ`-  
 K. #Zub `i`k#nteb  
 L. Kgf`i Kv#ŋŋ#t` #axbZv c#vb Ki#eb  
 M. Kgf`i gv#S`v#qZ; f#M K#i t`#eb  
 N. Kgf`i Rb` cĭk#ŋ#Yi e`e`v Ki#eb|
2. ubt#Pi tKvb#U m#zKg#e`e`vcbvi mnvqK?  
 K. ubt`R c#vb  
 L. m#ov`# AvBb Kv#ly c#vqb  
 M. m#ov`# `v#qZ; e#Eb  
 N. m#y i gv#v#mK m#úK`vcb|
3. m#z#te Kgf#úv`tbi Rb` tKvb #R#v#m#U me#c#ŋv c#qvRb?  
 K. `ŋZv  
 L. Ávb  
 M. t#ŋYv  
 N. cĭk#ŋY|

**Av) iPbv#j-K cĭæ**

1. Kgf#e`e`vcbvi n#vZqvi I tK#kj m#ú#K`GKuU m#ovag#e`vL`v c#vb Kiab|



**m#WK DĚi**

- A) 1| L, 2| N, 3| M|





**cW 1**

**tbZtZj A\_©msÁv I avi Yv**

**Dtík**

GB cW tktl Avcib—

- tbZZj:ej tZ wK tevSvq Zv e`vL`v Ki tZ cvi teb;
- tbZv ev tbZtZj msÁv c0vb Ki tZ cvi teb Ges
- tbZZj:m=útk©mýúó avi Yv c0vfb mŋg nteb|

Avgiv Rvmb, 0tbZZj káwU mSMVb, `j ev c0Z0vfb Kgc©m=úv`b c0muvv m½ ubweofvte m=ú,³| GwU Ggb GKwU kw³ hv c0Z0vfb Kgcŋe,`i gvts cŋvetKi KvR Kti Ges Zv` i tK KtgDÍxß Kti | tbZZtK GKwU c0muvv etj AvfwnZ Kiv hvq| GwU Ggb GKwU c0muvv hvi gva`tg tbZv Zvi wbt`Rbv, civgk,©tKŠkj Ges mteŋcwi Zvi PwvwlK `enkó` 0viv `tj i m`m`i AvPvi AvPiY I gtbvfvtei Dci cŋve we`li Ktib|

**tbZtZj msÁv**

tbZZtK wevfbwvŋvme` ev wevfbwvŋvte msÁvqZ Kti tQb| R.M. Stoghill Gi fvlvq "Leadership is a process of influencing the activities of an organised group in the tasks of goal setting and goal achieving."<sup>1</sup> A\_ŋ 0tbZZj:n`Q j ŋ" wbaŋY I j ŋ" ARŋbi Rb" GKwU msNex Kgcŋ tji Kvŋŋj tK cŋvmeZ Kivi c0muvv|0

Harold Koontz Ges CO Donnell; Hollander; M.J. Gannon Ges Keith Davis c0ŋE wKŋvme`t`i c0E msÁv t`tK c0xqgvb nq th tbZZj:n`Q GKwU cŋve we`li Kvix c0muvv hv `tj i m`m`i tK Kvŋ©m=úv`tb DrmwnZ Kti | Good Gi Dictionary of Education G tbZZj:A\_©ejv n`qtQ, "Leadership is the ability and readiness to inspire, guide, direct or manage others."<sup>2</sup> weL`vZ MtelK KvUŋii gtz "Leadership is the process of influencing the activities of an organised group toward goal setting and goal achievement."

tbZtZj wevfbwvmsÁv wek- IY Kij t`Lv hvq, Kvŋiv gtz tbZZj:n`Q wbt`Rbv c0vb Ges Kvŋiv gtz tbZZj:n`Q cŋvmeZ Kiv| Avevi, Kvŋiv gtz tbZZj:n`Q j ŋ" wbaŋY Avi Kvŋiv gtz tbZZj:n`Q j ŋ" ARŋ| gtb ivL`tZ nte cKZ.tbZv wZwbB, wvwb msMVb ev `tj i evnŋi wevObwvKiv Dtík" tcvlY Ktib bv| Zwi KvŋQ msMVtbi mveŋ Dtík`B c0v| GB mveŋ Dtík`i m=ŋL e`w³MZ ev `j xq Dtík" wej xb n`q hvq|

<sup>1</sup> L.D. Gupta, Educational Administration, P-89.  
<sup>2</sup> L.D. Gupta, Educational Administration, P-89.

### tbZtZj aviYv

tbZtZj mbvZb aviYvi cŃZ ᄡocvZ KiŃj Argiv t`LŃZ cve tbZZj.nŃ"Q GKwU mnRvZ ᄡ Y A\_Ń tKvb tKvb gvby tbZv ntqB RbŃq, ZvŃ iŃK ᄡZui Kiv hvq bv| G aviYvi AbŃvixŃ i gŃZ wKQygvby `jŃK kvmb Kivi gZ PwiiwŃK `enkó`veij wbtqB RbMŃY KŃib| RbMZfvŃe KwZcq wŃkl ᄡYi Awakvix e`wŃMYB tbZvi fvqKv cij b KiŃZ mŃg| GB aviYv AbŃvix wŃkl ᄡ Y h\_v- Ávb, KíbvkwŃ, `ah, mnbkxj Zv, `Ń`wŃZv Ges gvbwKfvŃe mŃy i e`wŃMY tbZv nevi thwM`|

mgŃqi cwieZŃbi mŃ½ tbZtZj mbvZb aviYv cwieZŃ ntqŃQ| tbZtZj Dci MŃelYv I wŃŃŃfvebvi dtj tbZtZj mbvZb aviYv fŃ ev wŃ\_v etj cŃwŃYZ ntqŃQ| AvawŃK aviYv AbŃvix cŃkŃŃY Ges DEg I Av`k`cŃkvmbK ev cŃwŃZŃwbK tbZvi mŃ½ NwbŃ mnŃhvŃMi gva`Ńg tbZtZj ᄡ Yveij ARŃ Ges tbZZj.MVb mŃe| wŃklÁMY `ŃaiŃbi cŃkŃŃYi K\_v DŃj L KŃiŃQb- cŃwŃZŃwbK cŃkŃŃY (Institutional Training) Ges KgŃvjxb cŃkŃŃY (On-the-Job Training)| cŃwŃZŃwbK cŃkŃŃYi gva`Ńg tbZtZj wŃfbae ᄡ Yveij, tbZtZj KivŃveij Ges tKŃkj mŃúŃK`ZwŃĚK Ávb I aviYv RbŃq| KgŃvjxb cŃkŃŃYi dtj ZwŃĚK ÁvbŃK e`enwii K tŃŃŃ cŃŃqvŃMi Rb` gvby mŃPŃ nq|

KvŃRB t`Lv hvŃ"Q th, GKRB AvawŃK tbZv tKej cŃwŃZŃwb cŃvwb bb, Zui wŃZi AvawŃK tbZtZj ᄡ Yveij I PwiiwŃK `enkŃó`i cŃZdj b ev AvPiwŃYK cŃkvk Aek`B NUŃZ nŃe| tKvb Ae`ŃŃZB wŃwb GKKfvŃe wŃR wŃxvŃŃŃ mevi Dci PwŃŃŃ t`Ńeb bv| A\_Ń GKRB AvawŃK tbZv nŃeb MYZwŃŃK i wŃZbwŃZŃ wŃkŃmŃ| `Ńj i mKŃj i mnŃhvŃMZvq wŃwb cŃwŃZŃwbŃK j ŃŃ` ARŃbi w`ŃK GwŃŃŃ wŃŃg hvŃeb| L.D. Gupta-i gŃZ, "Leadership infact is not something magical or mystical but is a set of skills that people can learn and develop."<sup>3</sup>

tKej gvŃŃ wŃ`vj q ev cŃwŃZŃwb cŃvwb th tbZZj.t`Ńeb Zv bq, cŃwŃZŃwb i Ab`vb` m`m` h\_v Dcva`ŃŃ, mnKvix cŃvwb wŃŃŃK, wŃfvŃwŃq cŃvwb, wŃŃŃKgvŃj x cŃZŃŃK wŃR wŃR cwi gŃŃŃ tbZZj.`ŃŃbi Awakvix| ZŃŃ i cŃZŃŃKiB wŃR cwi gŃŃŃ wŃQywbŃ Ń j ŃŃ` Ges wŃR wŃR Avl Zvq tŃvU `j ev Dc`j \_vKŃZ cvŃi| GB tŃvU `j ev Dc`j ŃK wŃw`Ń j ŃŃ` awŃZ Kiv ev cŃŃwŃZ Kivi ga` w`Ńg Zuiw tbZvi fvqKv cij b KŃi \_ŃŃKb|

wŃŃŃ cŃwŃZŃwb wŃŃŃ Argiv `ŃaiŃbi tbZZj.t`LŃZ cvB- (1) AvbŃwbK I (2) AvbŃwbK| AvbŃwbK tbZZj.wŃbŃx AvŃ Ńki gva`Ńg ntq \_ŃŃK| hv` KLbI tKvb KviŃY AvbŃwbK tbZZj.e`\_Ńvq chŃwŃZ nq, ZLb AvbŃwbK tbZZj.AvŃŃKv KŃi|

<sup>3</sup> L.D. Gupta, Educational Administration, P-89.



**cv#VĒi gj`iqb: 1**

**A) eū ubePbx cĭæ**

m#WK DĒi ūb#`Rgj-K Aŋiu#K eĒmqZ Kiab| (D`vniY: Avcbvi ūbe#PZ DĒi#U K ntj G#K (K) eĒmqZ Kiab)

1. Av#K avi Yv Abŋvqx #K f#te tbZ#Zji , Yve#j AR# Kiv hvq?
  - K. mnRvZ cĕ#Ēi ōviv
  - L. tj Lvcovi gva`tg
  - M. cĭkŋ#Yi gva`tg
  - N. KgZrciZvi gva`tg|
  
2. ūb#Pi tKv#U tbZ#Zji ms#Vi Avl Ziq c#o?
  - K. Kg#m#úv`b
  - L. m#y`úK#rcb
  - M. c#f#meZ Kiv
  - N. D#i`k` ūb#fcY|

**Av) iPb#qj-K cĭæ**

1. tbZZ#ej #Z #K tevSvq? tbZ#Zji ms#V D#j #ce# G m#ú#K#GK#U m#y#ó avi Yv c#ŋvb Kiab| tbZ#Zji mbvZb Ges Av#K avi Yvi g#a` #K cv`#` ūe`g#vb?



**m#WK DĒi**

- A) 1| M, 3| M|

**cW 2**

**tbZtZj UvBc ev aib**

**Dfík**

GB cW tk#l Avc#b—

- tbZtZj wefbaUvBc ev aib wefbaUvBc i Ki#Z cvi#eb I wefbaUvBc i tbZtZj `enkó` Ztj ai#Z cvi#eb Ges
- gb`wÉK, mvgw#RK I AvPiwYK `wó#KvY t\_#K tbZtZj e`vL`v c0vb Ki#Z cvi#eb|

G hver Avtj vPbv t\_#K cZxqgvb nh th, tbZZj.e`w3i Pwiiw#K , Yvej i m#½ Nubôf#te m#ú3| ev`heKc#f#l e`w3i Pwiiw#K MVb Ges `enkó` nj e`w3#Zj Ab`Zg Drm| t`Lv t#t0 wKQywe#kl , #Yi Awakvix e`w3MY thwM` tbZv etj we#e#PZ nb h\_v- Ávb, cÁv, `f`wó, mZZv, Kg#úpv, DÍxcbv, Drm#v, `wqZ#eva, m#y i e`w3Z; BZ`w` , Y, wj tbZZ#K Drm#vZ K#i| m#aviYZ G mKj , #Yi Awakvix e`w3MY thwM` tbZv etj we#e#PZ nb|

m#úú#ZK wKQyM#elYv t\_#K tbZvi `w# AvPiwYK w`#Ki cwiPq cvlqv hvq| GKwU m#sMv#bK Df`#M (Initiating Structure) Ab`wU we#veb (Consideration)| c0\_tg#v3 t#f#t#l th , Y, wj t`Lv hvq tm, wj nj : (K) we#fbaKv#R Df`#M M#hY; (2) `tj i m`m`#i c0Z0v#bi we#fbaKv#R m#uq AskM#h#Y D0yKiY; (M) mnKg#` i m#½ m#úúK`vc#; (N) cvi`úwi K thwM#h#v#Mi m#b#w`# w#f#É `vc# Ges (N) `jxq Kg#v#v m#úú#K#mKj #K AeinZKiY|

we#vebgj-K AvPi#Yi t#f#t#l tbZv mnKg#` i c0Z mü`q Ges mn#b#y#Zk#j nb| tbZv Ges mnKg#` i cvi`úwi K k#v#v#t#v#tai dtj KvR mnR Ges Zjw#SZ nq|

tbZtZj tk#Ywe#`vm Ki#Z w#tq ejv n#tq#0, "Some one born great, some achieve greatness and others have greatness thrust upon them."

GB D#v3i Avtj v#K tbZZ#K c0vbZ wZb#w tk#Y#Z f#M Kiv th#Z cv#i:

**(K) K`wi k tgv#K tbZv**

w#w#b Rb#MZf#teB tbZtZj mg#yq `enkó`i Awakvix| A\_# GB tk#Yi tbZv tbZtZj c0\_qv#b#q , Yvej w#tq#B Rb#M#h#Y K#i#b| Zviv mn#t#RB `tj i m`m`#i w#f#Zi t#0Yv m#úú Ki#Z cv#i#b Ges `tj i Av`v AR#b m#f#g nb|

**(L) AvbôubK I cwițekMZ tbZv**

GB aitbi tbZv`j, tMvÎ ev esk ci`úivq AwaKvsk tŋtÎ RbŋmÎ tbZZ;cŰB nb| Zte gtb ivLtZ nte G aitbi tbZvțK tbZtZji , Yvej ARŰ KițZ nq|

**(M) KvhRi tbZZj.**

`j ev mSMvțbi Aw`Zj; uUwKtq ivLvi Rb` Dchŷ , Yvej m`ubæKvțiv Dci G aitbi tbZZj.b`ıKiv nq| mvariYZ mgthvM`Zvm`ubæKtqKRțbi ga` t\_țK G aitbi tbZv ubeŲb Kiv nq| tbZv wnmıte GKRB we`'ij q cãvb G aitbi tbZtZji chŲq ctob|

MtelK ÷vBj Abŋvqx tbZZțK wbgwj uLZfıte wPwYZ KtițQb:

- `ıZvıŝK tbZZj.
- MYZvıŝK tbZZj.
- Avgj vZvıŝK tbZZj.
- K`mi kțguUK tbZZj.
- Aeva tbZZj|

`ıZvıŝK tbZtZji meŲŋtÎ Ges memgq tbZv wbtR wmvıŝıMhY Kti b| G aitbi tbZtZji AțbK mgq`tj i`r`DıtcwŲZ nțq\_vțK| AvaybK wețk; G aitbi tbZvi Aw`Zj; wej ev bvB ej tj Pțj | eZŲvb wețk; Pwıv` Abŋvqx MYZvıŝK tbZZj; meŲ`ıKZ| Avgj v Rıvb, G aitbi tbZtZji; tbZv mnKgŲ` i mț½ Avj vc Avtj vPbv I mgțSvZvi gva`țg wmvıŝıMhY Kti\_vțKb| Avgj vZvıŝK tbZv c`vwaKvi etj tbZZcŰB nb| GKRB we`'ij q cãvb G aitbi tbZvi chŲq ctob| mvariYZ Avgj vZvıŝK tbZtZji; `ıZvıŝK, MYZvıŝK I Aeva tbZtZji GK wgtıjc tPvțL ctob| K`mi kțguUK tbZv RbMZfıte tbZtZji , Yvej wbtq Rbŋb| G aitbi Abb` mvariY e`w`țZji AwaKvix tbZv Avgvț` i wŲŲv cŰZôvb , wj țZ bvB ej tj B Pțj | Aeva tbZtZji Avl Zıvq`tj i m`m`e,` hıv I Acvi`ıaxbZv tfvM Kti b, msMvB ev cŰZôvțbi Dıık` mvațbi Rb` G aitbi tbZZj; Kvg` bq| gtb ivLv cŰqvRb, mdj tbZZj; G mKj tKvb ÷vBtj i B Pig we`'țZ Ae`vb Kti bv|

tbZZțK wețkl ÁMY wZb aitbi` wŲțKıv t\_țK Aetj vKb KtițQb- (1) gb`ıwĚK (2) mgvRZvıŝK Ges (3) AvPiıwYK|

**gb`ıwĚK` wŲțKıv**

gb`ıwĚK` wŲțKıvY tbZvi wKQy, Y ev`ewk`ovej i Dci , iaZj Avıvc Kiv nțqțQ| Ralph M. Stoghil 124ıU tbZtZji Dci MtelYv KtițQb| Zıı gțZ GKRB e`w` tKej gvÎ wR`^wKQy, Y ev`ewk`ovej wbtq mdj tbZv nțZ cvıib bv, tbZvi wR`^

ḡ Ae GW#Kkb

PwiwĪK c"Uvb© Ges Abryvixḡi PwiwĪK ḡenkó", Kvhḡej, j ḡ" I DfĪtk"i gay  
mḡútkḡ Dci tbZḡZji mvdj" ḡbfḡ Kḡi | ÷Mnj tbZvi tKvb meḡkl ḡenkó"i Dci  
ḡiḡZj Avḡivc Kḡib ḡb |

### **mgvRZwĒK ḡḡḡKvY**

mgvRZwĒK ḡḡḡKvY Ablyvqx ḡZwbB tbZv ḡhḡb ḡḡi mḡmḡ"i Norm tK eḡḡZ cvḡib  
Ges Zvḡ"i mḡḡ ḡḡḡRḡK GKvZḡ Kḡi tḡLb | ḡḡi mḡḡ GKvZḡV ZḡK mggḡḡbi DḡP  
Avḡḡb AvḡḡZ Kḡi hvi dḡj ḡZwb mḡḡR ḡḡK ḡḡḡY KḡiZ cvḡib | mgvRZwĒK eḡLḡ  
Ablyvqx tbZv ḡḡi tmḡUḡḡ Ges Pwvḡ mḡḡR eḡḡZ cvḡib Ges ḡḡK Ggbfvḡe  
cvi Pwv Z Kḡib hvḡZ mḡḡR Zviv j ḡḡ" tḡḡḡZ cvḡi | mgvRZwĒK ḡḡZ tbZZj: nḡ"Q  
tbZv Ges mnKḡḡev ḡḡi ḡḡa" cvi ḡḡi K Avḡvb-cḡvb | GB Avḡvb-cḡvb ḡḡi cḡZw  
mḡm" ḡR ḡR fḡḡKv cvj b Kḡib | ḡKḡ cḡZw mḡḡ"i fḡḡKv GKw Aciw tḡK  
CḡK | ". . . . Leadership is truly a process of interaction each participant in  
the interaction may be said to play a role and these roles must be in some  
way differentiated from each other."<sup>4</sup>

### **AvPiwYK ḡḡḡKvY**

AvPiwYK ḡḡḡKvY tbZvi eḡḡMZ PwiwĪK ḡenkó" Aḡcḡḡv Zwi eḡḡ"K AvPiḡYi Dci  
AvḡKZi ḡiḡZj Avḡivc Kiv nḡ | AvPiwYK ḡḡḡKvY-

1. tbZv ḡḡi mḡḡ Avḡj vPbvḡḡbḡZ Ges msMVḡbi Rb" j ḡ" ḡbaḡY Kḡib |
2. hvḡ"iḡ ḡZwb tbZZj: tḡb, Zvḡ"i mḡḡ AvḡḡḡḡbK, Dḡ Ges mḡḡRbK mḡúKḡḡto  
tZvḡj b |
3. ḡZwb ḡḡi Avḡv-AvḡvLv, thvM"Zv, kvḡ Ges ḡḡZv mḡúKḡḡ qvḡKdnvj ḡḡKb |

MḡelKḡ"i MḡelYvj ä Zḡ" tḡK AvI KḡqK aiḡbi tbZḡZji cvi Pq cvl qv hvq | ḡZer.  
tbZZj. Ggb GKwU tbZZj | ÷"Uvm jxwvi (Status Leader) Aciw GKwU DḡvniY |  
÷"Uvm jxwvi mḡaviYZ tbZvi cḡ ḡḡḡv tR"ḡZv Ges KZḡZji Dci ḡbfḡ Kḡi |  
Avḡḡ"i tḡki ḡKḡḡv cḡZḡvb ḡḡj ḡZ tbZZj: mḡaviYZfvḡe ÷"Uvm tKw"K | cḡZḡvbi  
cḡvb ḡḡḡḡe tḡWḡv ÷vi Aḡev Aaḡḡ | ÷"Uvm jxwvi fḡḡKv cvj b Kḡib | cḡZḡvb  
cḡvḡbi ḡbeḡḡ Avḡ"k Ppvḡḡ etj meḡḡPZ nḡ | ÷"Uvm jxwvi EaḡZb KZḡḡ KZR.  
ḡḡḡḡḡḡ nb |

÷"Uvm jxwviḡK Avḡiv Avḡḡḡḡḡ ev Avḡḡḡḡḡ tbZv ev ḡḡ-Rḡj De-Jure tbZv ejḡZ  
cvi | ḡḡ-Rḡj tbZv AvBbZ ev meavbZ tbZZcḡḡ nb | G Qvovl iḡḡḡḡ De-Facto tbZv |  
ḡḡ-dḡḡḡḡ tbZv Kvhḡ tbZZj: tḡb | GKRB meḡ"vj q cḡvb ev Kḡj ḡRi Aaḡḡ KZḡḡ KZR.  
ḡḡḡḡḡḡ nb hv Avḡḡḡḡ ejv nḡḡḡḡ | Zwiḡ th ḡḡi mḡḡ KvR Kḡib, tm ḡj KZR.

<sup>4</sup> Gordon, Group Central Leadership, P-51.

wtqvmcŃ nb bv| tmRb`B Zviv `vBwiK cŃvb ntj l mwZ`Kvi tbZv bvl ntZ ctib|  
mwZ`Kvi whub tbZv, ZvtK ejv nq De-Facto tbZv| wW-d`vt±v tbZv ntZ ntj hv cŃqvRb,  
Zv nj ZvtK `j KZR.MŃYthvM` ntZ nte| wZwb hv`i Rb` Ges hv`i m½ Kvr  
Kiteb, Zviv thb eŃtZ cvti wZwb ewniwMZ tKD bb, wZwb Zvt`iB GKRB| Zvntj t`Lv  
hv`Q, GKRB ÷`vUvm ev Awclmqj tbZv wW-Rji l ntZ cvtib, Avevi wW-d`vt±v l ntZ  
ctib| hLb wZwb `tj i m½ GKvZŃ ntq Kvr Ktib, mnKgŃ`i wfZi `jxq tPZbv l  
cvi`úwiK kŃvtera RvMŃ Ktib, ZLb wZwb wW-d`vt±v tbZv| Avevi hLb AvBbZ  
wtqvmcŃ ntq `jtK kvmb Ktib, ev `tj i tKqv-tUKvi (Care Taker) wmwte Kvr  
Ktib, ZLb wZwb De-Jure tbZv|

GLvtb wCZer. ev Fatherly Leadership m`útk`wKQyejv hvq| maviYZ cwievti whub  
etqvtR`ô ev cwievi cŃvb ZvtKB tbZv wmwte gvb` Kiv nq| cwievti mKj m`m`  
wtkZŃvte Zui KZŃ. Ges Avt`k-wt`R tgb tbb| `tj i cŃZ Zui `wŃw½ wKQyv  
wCZmjf| wZwb wtRI gtb Ktib cwievti etqvtR`ô weavq wZwb meŃcŃv Avbx Ges  
wZwb hv Ktib Zv cwievti g½tj i Rb`B Ktib| Avgt`i wŃv cŃZövb, wjtZl G  
aitbi cŃZövb cŃvb itqtOb, hviv wtRt`itK wCZer. tbZtZj AwKvix etj gtb Ktib|  
wCZer. tbZZŃK mwZ`Kvi At`wW-d`vt±v tbZZj. ejv hvq bv| KviY G aitbi tbZtZj  
tbZvi AwZgvŃvq AwacZ` Ges `tj i m`m`i tbZvi Dci AwZgvŃvq wbfŃkxj Zv Zvt`i  
`vfwek weKvtki c`tK iæ Kti t`q|





### **cvtVĒi gj`iqb: 2**

#### **A) eū ubePbx cĳæ**

mĳWK DĒi ubt`Rgj-K AŋiU#K eĒmqZ Kiab | (D`vniY: Avcbri ubePZ DĒiU K ntj G#K (K) eĒmqZ Kiab)

1. tbZvi mvsMvubK D#`vM ej tZ tKvbuU#K tevSvq?
  - K. Avt`k ubt`R cųvb
  - L. cvi`úwi K thvMvthv#Mi mjbw`Œ wfvĒ`vcb
  - M. mnvbfwZkxj g#bvfve cųkŒ
  - N. Dct`k cųvb|
  
2. GKRB we`ij q c#vb tKvb tk#Yi tbZtZji Avl Zvq ctob?
  - K. AvbŋmbK tbZZj.
  - L. K`vni R#guUK tbZZj.
  - M. Avgj vZwšK tbZZj.
  - N. MYZwšK tbZZj|
  
3. mgvRZwĒK`w#tKvY Abjvqx tbZvi tKvb`ewktųi Dci tbZtZji mvdj`wbfP K#i?
  - K. tbZvi mnRvZ`Yvevj
  - L. tbZvi Ges`tj i g#a`cvi`úwi K Av`vb cųvb
  - M. tbZvi emn`K AvPiY
  - N. tbZvi Avt`k cųv#bi ŋgZv|
  
4. wW-d`v#±v (De-Facto) tbZv ej tZ tKvb ai#bi tbZv#K tevSvq?
  - K. whub AvBbZ tbZZcųB nb
  - L. whub mnRvZ`Yvevj i Œviv tbZZcųB nb
  - M. whub`j KZR.M#Y#h#M`ntq tbZZcųB nb
  - N. whub etqvtR`Œ weavq tbZZcųB nb|

#### **Av) iPbvgj-K cĳæ**

1. tbZtZji UvBc ev aib m#ú#K#GKuU hy#wbfP I MVbgj-K e#e` tck Kiab| Avgt`i we`jq, wj i Rb` tKvb ai#bi tbZtZji cųqvRb?



### **mĳWK DĒi**

- A) 1| L, 2| M, 3| L, 4| M|



ḡ Ae GW#Kkb

Kiteb| 0ZxqZt 1Z1b mnKg#`i c0Z mü`q Ges mnvbywZkxj nteb| Zui Ges mnKg#`i gv#S cvi`úwi K k3v#teva mKj tK 1b0vi m#½`wqZj;cvj tb D0y Kite|

c`waKvi etj tKD hLb c0Z0vb c0v#bi`wqZc0B nb, ZLb 1Z1b tmB c`msw# mKj`wqZj; I KZ#`cuj b K#ib Ges 1gZv I c0Zc#E tfvM K#ib| 1Z1b Aaxb`#`i#K Av#k 1b#R c0vb K#ib Ges Zv#i#K 1bqšY I cwiPvj bv K#ib| GLv#b 1Z1b tKej gv# GKRb 1k1v c#vmK, tbZv bb| tbZv nevi Rb`AvZwi<sup>3</sup> AvI 1K0j; c0qvRb i#q#Q| Zv nj - mnKg#`i k3v-fvj evmv,`#KwZ.Ges`Zt0Z#AvbM#Z`AR#|

### tbZv 1nm#te we`vj q c0v#bi , Yvevj

tbZv 1nm#te we`vj q c0v#bi , Yvevj Av#j vPbri c0#v#j 1bgvj 1LZ 1el q, 1j we#ePbv Kiv c0qvRb:

- tbZZj;mvavi YZ`#j i AvI Zvq c0qvM Kiv nq|`#fveKfv#eB we`vj q c0vb GKRb`j tbZv 1nm#te`j tK mnv#`m#thvMZvi e#cv#i Kv#Ri fvgKv i#Lb|
- tbZ#Zj; gb`1#E#K 1etk#tY tbZvi Rb#MZ`#fveK , Yvevj tK c0arb`t`l qv n#q#Q thgb-`ah,°mnbkxj Zv, gv#vmK m#i Zv,`#`1k#Zv, mrvnmKZv BZ`w`|
- tbZ#Zj; mgvRZv#E#K 1etk#tY e#v<sup>3</sup> A#c1v cwi#ek I cwi#cwk#RZvi Dci , i#Zj; Av#vc Kiv n#q#Q| cwi#cwk#R Dcv`vb h\_v: c0Z0v#bi Kv#Ri gv#v, tbZvi`1jZv, mnKg#`i m#½ m#úK,° c0Z0v#bi cwi#ekMZ Ae`v BZ`w`i 0viv tbZvi mvdj`1ba#i Z nq|
- tbZZj;Ggb GKwU c0#qv thLv#b tbZv`#j i D#i`k`AR# I Kv#m#úv`tb mnvqZv K#ib Ges`j tK j`1j`AR#bi w`tK GwM#q 1b#q hvb|
- tbZv`#j i m`m#t`i AvPi#Yi 1bqšK I c#veK 1nm#te KvR K#ib|

Dc#iv<sup>3</sup> 1el q, 1j tK mvg#b ti#L tbZv 1nm#te we`vj q c0v#bi , Yvevj i GKwU Zv#j Kv c0vb Kiv hvq:

- tgvnbxq e#v<sup>3</sup>Zj
- MYZv#šK`#f#w#½
- Av#Z#cj wä Ges AvZ#c#Z`q
- `#`1k#Zv
- MwZkxj Zv (Dynamism) ev cwi#eZ# tK t#tb tbevi kw<sup>3</sup>
- mnKg#`i m#½ m#úK# cwi`úwi K k3v#teva
- mgm#v tgvKv#ej vi kw<sup>3</sup>
- mgm#vi mg#q#vPZ mgvav#bi 1gZv
- K\_v I Kv#Ri 1qj (`^0Zv)
- thvM#thv#Mi`1jZv
- mgvR gv#b#i i m#½ m#úK#

### wekte tbZtZi , Yveij ARB Kiv hvq?

Avqiv Rvb, we`ij q cãvb GKvavti cãvmK Ges tbZv GB Dfquea fvgKv cvj b Kti b/ cãvmK wnmvte Zui`vqZ; we`ij tqi wekŷvi gvfbvbqtb mtpó n l qv/ tbZv wnmvte Zui`vqZ; msukó mKtj i Rb` wekŷvi cwi tek`Zwi Kti t`l qv/ KvtrB Ztk tbZtZi emãZ , Yveij Aek`B ARB Kitz nte/ wbgvj wLZ we l q, wj i cãZ`wocvZ Kiv thtZ cvti |

1. we`ij q cãvb Zui`xNŷ tbi AvfãZvi Avtj vtK tbZtZi emãZ , Yveij mgr ARB Kiteb |
2. Zui tj Licov, Ávb, l cãvi m½ mnRvZ , Yveij l e`wŷtZi msugkY NwUtq wZwb tbZtZi emãZ , Yveij mgr ARB mtpó nteb |
3. mgq wek t l cãqvRtb Ztk U`vKwKk ev tKŠkj Aej`b Kitz nte |
4. mnKgŷ`i wFzi h\_vh\_`vqZ; l KZŷ; Acŷ Ges Kvtr i`KwZ. cãv tbi gva`tg tbZtZi , Yveij wekvtk mnvqZv Kiteb |
5. Ztk Aek`B cãkŷY wbtZ nte | AvRtKi cwi emZŷ wek; tbZtZi , Yveij wekvtki Rb` cãkŷYi GKvš cãqvRb |

### cvfVvEi gj`vq- 3



#### A) eü wbePbx cãæ

mãWK DËi wbt`Rgj-K Aŷi wUtk eFvqZ Kiab | (D`vniY: Avcbvi wbePZ DËi w K ntj GtK (K) eFvqZ Kiab)

1. tbZv wnmvte we`ij q cãv tbi wekŷcŷv , iæZŷv`vqZ; tKvbwU?
  - K. `j tK mŷwi Pj bv Kiv
  - L. `j tK mŷ i fite wqšŷ Kiv
  - M. wekŷvi gvfbvbqtb mtpó n l qv
  - N. `tj i mngwZv ARB mŷg n l qv |
2. tbZv wnmvte cãvb wekŷtKi Ab`Zg , Y tKvbwU?
  - K. Avt`k-wbt`R cãv tbi ŷgZv
  - L. wqšŷ l cwi Pj tbi ŷgZv
  - M. mnKgŷ`i AvbMZ` ARB i ŷgZv
  - N. AvBb Kvby cãqvMi ŷgZv |

#### Av) iPbvqj-K cãæ

1. tbZv wnmvte cãvb wekŷtKi`vqZ; KZŷ` l , Yveij i GKw msuŷB cwi wPvZ cãvb Kiab |



mãWK DËi

A) 1 | N, 2 | M |



**cW 1**

**umxvšlMhYi A\_©, iaZjGes cŕqvRbxqZv**

**Dt`ik`**

GB cW tk`l Avcib—

- umxvšlMhY ej tZ wk tevSvq Zv wj uLZ ev tgšlLKfvte cŕvk Ki tZ cvi teb Ges
- cŕZövb cwi Pvj bvi tŕŕt` umxvšlMhYi , iaZjI cŕqvRbxqZv e`vL`v Ki tZ cvi teb|

**umxvšlMhYi A\_©**

t`tki mmeR wkŕŕv e`e`vi Dbqb, cŕvi ev cwi Pvj bv msµvšl mi Kwii umxvšl mrvavi YZ wevfbaAvt`k, ubt`R ev cwi ct`I i gva`tg Avgiv RvbtZ cwi | cŕZömbK chŕqI GKRb cŕZövb cŕvbtK wevfbaelŕq umxvšl MhY Ki tZ nq| we`ij q cwi Pvj bv Ki tZ wMtq cŕqk wevfbaevi w`wzi D`e nq hLb umxvšl MhY Acwi nvh`ntq cto| umxvšl MhY Ggb GKwU cŕµqv hv cŕZövtbi ``bw`b KvŕRi Aweŕ`Q` A½| GRb`B ej v nq cŕvmŕbi KvR umxvšlMhY w`ŕq i iæntq Avevi umxvšlMhYB tkI nq|

we`ij tqi GKvŕwŕgK gvb Dbqb Ges tm j tŕŕ` cwi Kí bv `Zii Ges ev`évqbcšv ubi fcy; wkŕŕv\_ŕ, wkŕŕK, wkŕŕvµg msµvšl weI qvej; mncvµµgK Kvŕŕevj cwi Pvj bv; EaŕZb KZŕŕŕi mŕ½ thvMŕthvM; mgvŕRi mŕ½ m`ú`Zv I thvMŕthvM iŕŕv; tŕŕZ AeKvŕVŕgvi Dbqb; cixŕŕv cwi Pvj bv; A\_ŕwZK e`e`vcbv BZ`w` eúnea tŕŕt` GKRb we`ij q cŕvbtK Anin umxvšlMhY Ki tZ nq| G mKj tKvb tKvb weI tŕq we`ij q cŕvb KLbI GKv umxvšl tbb| Zte AwaKvsk tŕŕt` msukŕ e`w`etMŕ mnŕthvMZv I gvŕgtZi wŕŕŕŕZ umxvšlMhY Kvŕŕmgvav nq| gŕb ivLŕZ nte mŕwK Ges hvŕcYŕumxvšlŕi Dci cŕZövtbi wevfbaKvŕRi mdj Zv ubfŕ Kŕi |

wetklÁMY umxvšlMhYtK GKwU cŕµqv etj DtjL KŕitQb| umxvšlMhYi wŕZi w`ŕq cŕZövtbi m`m`ŕi AvPiwYK `ewktó`i cwi Pq cvlqv hvq| umxvšl MhY cŕvmŕbi meŕcŕŕv , iaZcYŕKvR| cŕZövtbi hveZxq KvR umxvšlMhYi Dci ubfŕ Kŕi |

**umxvšlMhYi msAv**

cŕZövb cwi Pvj bvi Rb` cŕqvRbxq c`ŕŕc MhY, cwi Kí bv MhY I ev`évqb Ges D`mZ mgm`vej i mgvavŕbi ubŕgtŕE eúnea weKí cšvi ga` t`ŕk meŕcŕŕv DEg cšvŕi mŕPZb evQvBtK umxvšlMhY ej v hvq| GB mŕPZb I thšw`K evQvB Gi mŕ½ msukŕ e`w`etMŕ wŕŕŕŕŕvev Z\_v gubwK PŕŕRwZ| umxvšl MhYKvixi gubwK Ges gw`ŕ Pŕŕ mgvŕŕZ iŕŕci ewtccŕk NŕU umxvšlMhY cŕµqvq| KvŕRB umxvšlMhYtK gubwK cŕµqvI ej v hvq|

### ḡvšMhYi , iaz;I cŃqRbqZv

Avtj vPbvi cŃi tB ejv ntqtQ tKvb tKvb wtklÁ ḡvšMhY Ges cŃvmbtK mgv\_℞ etj MY Kti tQb| Zuv ḡvšMhYtK cŃvmbi tK>`le>`jZ ḡcb Kti tQb| Zt i gtZ cŃvmbi Ab`vb` Kvhewj ḡvšMhYi Dci wfpkyj | wtklÁMhYi G ai tbi gZvgZ t\_tK ḡvšMhYi , iaz;Dcj wä Kiv hvq| AvRtKi Dbz wtk; hys cYḡvšMhYi , iaz; Acwi mxg| tmRb`B wtklÁMY mei Kg Z\_ m`útkAeMZ ntq cŃB Zt\_ i Avtj vtK ḡvšMhYi cŃcvmZ| hys I Z\_ mgx ḡvšMhYi tŃt j Ń I Dfík` ubaŃtYi ci thvMhYiMi tPbB w`i Kiv nq Ges GtKK `ti GtKK ai tbi ḡvšMhYi `wqZ; AcY Kiv nq| Gfite AZ`šl mŃZl wbgqZwšK Dcvtq cŃvmbi KvR GwMtg hvq| w`ij q GKwU mvgwRK msMvB| mgvtRi cZ`vkv I cŃB w`ij tqi mwie℞ KgRvtŃi mt½ RwoZ| tmRb`B ḡvšMhYi DrklZv I , YMZ gvb GKvšfite Kvg`|

hys cYḡvšMhYi thgb GKwU wŃŃv cŃZŃvbtK j Ń` ARŃbi w`tK wbtq hvq, tZgubfite fj ḡvšMhYi cŃZŃvbtK Rb` mgr wec` tWtK AvbtZ cvti| wub cŃZŃvbtK cŃvb, ZtK m`vme`v G wltq mZK`\_vktZ nte| mwK I hys cYḡvšMhYi gra`tg wZub cŃZŃvbtK gvbexq Ges e`MZ Dcv`vbtK mteŃg e`envi wbwŃZ Kiteb Ges cŃZŃvbtK j Ń` ARŃbi w`tK GwMtg wbtq hvteb| ḡvšMhYi cŃuqvi mt½ mswkŃ wŃŃKe,` Ges g`vbtwRs KvgwU AskMhYi wbwŃZ Kiv w`ij q cŃvbtK Ab`Zg `wqZ;| GRb` ÷vd KvDwYj Ges g`vbtwRs KvgwU mfvq meŃŃZµtg G m`útkZ GKwU mgbw` Ń bmwZgvj v cŃqg Kiv thtZ cvti| QvŃ fuz,`cixŃv MhY, djvdj cŃKv, wŃŃK I Ab`vb` KgPvix` i wewfbcPvwn` v ciY I mgMŃwimbtK tŃt Zjor ḡvšMhYi ewwAZ dj etq AvtB| wŃS` gtb ivLtZ nte, Dtj wLZ tŃt, wj tZ cŃvb wŃŃtKi ctŃ GKv ZwoNwo Kti ḡvšMhYi tbi qv tKvbµtgB Kvg` ntZ cvti bv|

ḡvšMhYi m`útkZ wewfbcwtklÁi gZvgZ wtkdY Kitj Gi , iaz; h\_vh\_fite Abgweb Kiv hvq| mwBgb cŃvmbK `wqZ; I KvRtK ḡvšMhYi KvVtgv i gta` ti tL wetePbv Kti tQb| Zui gtZ cŃvmbK cŃuqvi meUvB ḡvšMhYi m`útkZ| Gi Dfík` nj `tji KvRtK mnRZi Kivi Rb` `jxq cŃPŃvbtK KvR j vMvbtv| wZub cŃZwU cŃvmbK cŃuqvtKB ḡvšMhYi Avtj vtK e`vL`v Kti tQb| tdqtj i wqšY ev Controlling Gi A\_`e`vL`v Kitz wMtg wZub etj tQb, cŃtg ḡvšMhYi , Yv, Y wBYŃ Kitz nte| AZtci µwUcYḡvšMhYi wj mstkvabce℞ Aaxb` mnKgŃ` i mg\_Ń Av`vq Kitz nte hvZ Zuv th ḡvšMhYi tbtb, Zv thb KZetŃi ḡvšMhYi mt½ m½wZcYŃq|

wj Pwdi (Litchfield) cŃvmbK cŃuqvtK GKwU wviU Pµ etj AvfinZ Kti tQb hvi gta` AtbK, wj ŃZ`ŃZ`Pµ i tqtQ| GB ŃZ`Pµ, wj i cŃZ`KwU GK GKwU wtkl `wqZ; cij tbi tKškj e nwwZqvi `tfc| GB Pµ ḡvšMhYi w`tq i iaz ntqtQ Ges tkl ntqtQ Reappraisal ev , Y wPvi w`tq| Reappraisal Gi Avtj vtK cŃvmbK ḡvšMhYi w`tq PµvKiti cŃvmbK cŃuqv AvwZŃ nt`Q|

wMŃd\_m (Griffiths) ḡvšMhYi tK cŃvmbK cŃuqvi tK>`le>`jZ cŃZ`vcb Kti tQb| ". . . . Griffiths asserted that the decision making process is the central process

of administration and that the central function of administration is directing and controlling the decision-making process.”<sup>1</sup>

we`ij q cwi Prj brq wmxvšl Mh̄tYi , iazj I cŋqvRbxqZv Dcj wä Kfi cŋZw cŋZövb cŋvbŋKB wmxvšlMh̄Y I ev`evqŋbi tŋŋŋ Kkx fvgKv ivLŋZ nŋe|



**civVēi gj`vqb: 1**

**A) eū ubePbx cŋæ**

mivK Dēi wbt`Rgj-K AŋiUŋK eŋvqZ Kiab| (D`vniY: Avcbri ubeŋPZ DēiU K ntj GŋK (K) eŋvqZ Kiab)

1. thšv³K wmxvšl ej ŋZ wbtPi tKvbUŋK tevSvq?
  - K. Z` msMh̄, Z` weŋkŋY, weKí cšv hvPvB, gj`vqb
  - L. mgm`v wPwýZKiY, Z` msMh̄ I weŋkŋY, weKí cšv hvPvB, mteŋEg cšv Mh̄Y
  - M. mgm`v wPwýZKiY, Z` weŋkŋY, dj v dj hvPvB, gj`vqb
  - N. mgm`v wPwýZKiY, mgm`v mgvavŋbi weŋfbæcšv D`vneb, dj v dj hvPvB, gj`vqb|
2. tKvb weŋkŋÁ cŋvmbK `vqZj I KvRŋK wmxvšl Mh̄tYi gŋa` tiŋL weŋPbv KŋiŋQb?
  - K. tdqj
  - L. wj Pwŋdì
  - M. mvBgb
  - N. wMŋd\_m|
3. tKvb weŋkŋÁ cŋvmbK cŋvqŋK wmxvšlMh̄tYi Pµ etj AvŋvŋZ KŋiŋQb?
  - K. tdqj
  - L. wj Pwŋdì
  - M. mvBgb
  - N. Mŋvj K|

**Av) iPbvŋj-K cŋæ**

1. wmxvšlMh̄Y ej ŋZ wK tevSvq? D`vni Y mnKvŋi evŋŋq w`b|
2. we`ij q cwi Prj brq wmxvšlMh̄tYi , iazj I cŋqvRbxqZv e`vL`v Kiab|



**mivK Dēi**

A) 1| L, 2| M, 3| L|

<sup>1</sup> Roald F. Campbell, Edwin M. Bridges and Raphael O. Nystrand, Introduction to Educational Administration, 5<sup>th</sup> edition, P-164.



**cW 2**

**ḥ̄m×všlMōtYi weifbævc Ges ḥ̄m×všl tkiMeb'im**

**Dt'ik"**

GB cW tk'fI Avicib—

- ḥ̄m×všlMōtYi weifbævc Dt'j L KiḥZ cviḥeb;
- cōZiW avḥc KiYxq KvḥRi weḥk'Y KiḥZ cviḥeb Ges
- ḥ̄m×všl tkiMeb'im Dt'j L ceḥ weifbæcKvi ḥ̄m×všleYḥv I e'vL'v KiḥZ cviḥeb|

**ḥ̄m×všlMōY cōiqv**

Avḡiv Rvib, mḡm'v mḡvavbKḥf' eū weK' cš'ri ga" t\_ḥK mḥPZbfivḥe hvPvB-evQvB-Gi ci mḥeḥKó.cš'mUḥK MōY Kivi bḡ ḥ̄m×všl MōY| ḥ̄m×všl thš'³K nḥZ cviḥi, Avevi Athš'³KI nḥZ cviḥi | GvU vbfḥ Kḥi ḥ̄m×všl MōY cōiqvq AvḡvZ i'vZ c×vZi Dci | eZḡvḥ cviḥv thš'³K ḥ̄m×všl Dci AvḥjvKcivZ Kiv nḥqḥQ|

mḥPZb evQvB Gi `vḥ ce'itḥq- (1) GKvU nḥ"Q mḡm'vi weḥk'Y, AcivU (2) ḥ̄m×všl MōY| mḡm'v weḥk'Yi ḡv'ḡ mḡm'vi KvY LḥR tei Kivi tPóv Kiv nq| Aciv'ḥK ḥ̄m×všl ḡv'ḡ mḡm'v vbi mbKḥf' m'vK c×vZḥK LḥR tei Kiv nq| mḡm'v weḥk'Yi cōḡg c`ḥḥc mḡm'vi weifbæv'ḥKi Dci AvḥjvKcivZ Kḥi mḡm'vU eYḥv I e'vL'v Kiv nq| GB chḥq ḥ̄m×všlMōYKvix LḥR tei KiḥZ tPóv Kḥib fḥ ev Mj` tKv\_vq, mḡm'vU Avḥ`Š tKvb weivU iKḥgi mḡm'v vKbv| vōZxq chḥq KvY mbr³ Kivi tPóv Kiv nq|

mḡm'vi KvY vPv'YZ nḥq hvevi ci ḥ̄m×všlMōYKvixi `vḥ mḡm'v mḡvavḥbi weifbæweK' cš'ri cōZ vbe× nq| GK GKvU weK' cš'ri GKv'vK dj ev Consequences nḥZ cviḥi | tKvb djvdj MōYḥvM" Avevi tKvbU MōYḥvM" bq| ḥ̄m×všlMōYKvixi `vḥqZ; nj Ggb cš' MōY Kiv hvv djvdj MōYḥvM" nḥe|

weiqvU D`vniḥYi m'v'vḥ" eḥvḥvḥ thḥZ cviḥi: aiv hvK, tKvb GKvU we`'vj q m'v'vḥK<sup>©</sup> Av'vḥveK Ges mḥPZb RbḥMvōx cḥk'vZḥj we`'vj qvUḥZ BstivR weḥḥqi cW'vḥ tḡvḥUB Av'vḥvḥjfc nḥ"Q bv A\_ḥ we`'vj qvU vKḥv\_ḥ iḥK h\_v\_ḥvḥe BstivR tKlvḥZ e`\_nḥ"Q| mḡm'vU weḥk'YKvḥj m'vK AvḡvavvU vov'ḥ Kivi jḥḥ' cōZóv cāvḥ th cḥk'vḥj Zḥj aiḥeb, tm\_vj nj:

- tKvb tKvb vKḥv\_ḥBstivR cviḥv Avḡvavi m'v'vḥ nḥ"Q?
- tKvb aiḥbi vKḥv\_ḥv mḡm'vi m'v'vḥ nḥ"Q bv?
- Avḡvavi cḥk'vZ. vK aiḥbi?
- th mKj vKḥv\_ḥBstivR vKlvḥZ vMḥq Avḡvavi m'v'vḥ nḥ"Q, Zviv tKv\_vq A\_ḥ Zviv tKvb tkiYḥZ Aa`qb KiḥQ?
- cōḡg KLv mḡm'vUv mḥ-civZ nq?
- Av` tKvb weḥ`kx fivv vKḥvḥi tḥḥḥ' vKḥv\_ḥv G aiḥbi Avḡvavi m'v'vḥ nḥ"Q vKbv?

Dctiv<sup>3</sup> ckeij i DEi LtR tei KitZ cvitj we`ij q cãvtbi ctŋ mgm`vi mWK cKwZ.  
I KviY Rivr mnR nte|

aiv hvK, t`Lv tMj me ukŋlv\_ŋ BstiuR ukLŷZ Amjeav nt`Q bv| tKej gvĭ KwZcq  
weŋkl `vb I weŋkl cãZôvb t\_ŷK AvMZ ukŋlv\_ŋ`i BstiuR ukLŷZ Kó nt`Q| ZLb cke  
KitZ nte, ukŋlv\_ŋ`i ce@ZP`ŋj tKvb cxwZŷZ BstiuR tkLvŷbv nZ Ges BstiuRŷZ  
Zvt`i Ávb I `ŋZvi gvb KZUKZ ukŋlv\_ŋ`i ce@ZP`ŋj\_ŋj tZ (A\_ŋ th `ŋj t\_ŷK  
Zviv eZŋvb `ŋj GŷmŷQ) BstiuR ukŋlv\_ŋ`i gvb Ges cxwZ h\_v\_ŋI mWK wQj ukbv?  
hw` t`Lv hvq th, ce@ZP`ŋj\_ŋj tKej gvĭ cVb, wj Lb I gly`kw<sup>3</sup>i Dci\_iazi  
t`lqv nZ hv eZŋvb we`ij tŋ Abgŷw`Z Ges eZŋvb we`ij tŋ BstiuR ejtZ civiv,  
BstiuRŷZ gŷbi K\_v cKvik Kiv Ges Communicative Approach of Teaching-tK  
(K\_vq Av`vb cãvb) AwKzi\_iazi t`lqv nt`Q, Zvntj mgm`wU tgvUvgwU mWKfite  
wPwŷZ ntŋ tMj |

Gi cieZPavtc we`ij q cãvb KZK\_ŋj weKí cšv wePvi weŋkl Y Kiŷeb:

(K) wZvb cŷi v mgm`wUB Dŷcŋlv KitZ cvitib;

(L) mgm`v mgvavŷbi Rb` GKvB cãB Zŷ\_`i mrvh` wŷZ cvitib;

(M) mgm`v msuvsŷZ\_` Zui mnKgŋ`i ŷK RivrŷZ cvitib|

cŷg weKí cšwU tŋŷŷ wbuŷvq ejv hvq, GuU mgm`v mgvavŷbi tŋŷŷ GKwU tbiZevPK  
c`ŷŷc| G aiŷbi c`ŷŷc ev`wŷfŷ MŷŷYi gva`tg mgm`vi mgvav Avkv Kiv hvq bv|  
wZxq cšwU tŋŷŷ djvdj fj g` DfqB ntZ cvitib| we`ij q cãvb GKv wvŷŷŷ wŷZ  
nqZev`ŷZ wZvb wvŷŷŷ wŷZ cvitib, Zte cieZŷZ mnKgŋ`i gvŷS weŷfc cãZwlvq  
mŷoi mŷevv\_ŷK| ZZxq weKí cšwU tŋŷŷ GKw`ŷK wKQv SŷK, Aciw`ŷK mŷj  
cvevi mŷevv iŷŷŷQ| cŷgZt mnKgŋ`i` gŷb KitZ cvitib GuU tKvb mgm`vB bq| tKbbv  
AwZ AímsL`K ukŋlv\_ŋ`GB mgm`vi Avl Zvq cŷo| wZxqZ: Z\_`chŷj vPbv I mgvavŷb  
tcãwŷZ wŷŷ mnKgŋ`i` Ah\_v Kvj tŋŷŷcb KitZ cvitib| Zey GBUKzAvkv Kiv hvq th,  
thŷnZzZxq cšwUŷZ mnKgŋ`i`ŷK wvŷŷŷ MŷŷYi mŷhvM t`lqv ntŷŷQ, Zviv GB wvŷŷŷ  
ev`evŷŷ wŷŷev`Z cãY nteb| cãZôvb cãvtbi Rb` KiYxq nj, wZvb cãZwU weKí cšvi  
djvdj wK ntZ cvitib Zv Abgŷŷŷbi tPóv Kiŷeb Ges tKvb cšwUŷK KZUKz\_iazi t`ŷeb  
Zv wbaŷŷ Y Kiŷeb|

hw` I cãZôvb cãvb wŷŷRB Ppvŷŷ wvŷŷŷ tŷeb, Z\_wc msŷkŷ e`w<sup>3</sup>etMŷ AskMŷY mgm`v  
wbu`ŷfŷte mbr<sup>3</sup>KiŷY mrvqZv Kiŷe Ges w`K wŷŷ`Rbv t`ŷe| cãqvRŷb mfv tWŷK wZvb  
msŷkŷ e`w<sup>3</sup>etMŷ mŷŷ weŷfŷweKí cšv\_ŋj mŷúŷK`tLvŷvLvŷ fite Avŷj vPbv Kiŷeb|  
Gfite meri mgŷeZ cãPóv Ges Avjvc Avŷj vPbv ga` w`ŷŷ mWK wvŷŷŷU tei ntŋ  
Avŷŷe| GB tŋŷŷŷ cãZôvb cãvb th wvŷŷŷŷ tŷeb, Zv KLbB Zui GKK wvŷŷŷŷ nteb,  
GuU nte msMVŷbi wvŷŷŷŷ| "Only after analyzing all of the cues supplied by the  
involvement of these various people in the organization, does the chief

administrator make the decision. In a real sense, the decision is an organization one.”<sup>2</sup>

### **umxvšlMhYi wefbaevc**

Dctiv<sup>3</sup> Avtj vPbvi tciŋtZ umxvšlMhYi wefbaevc, uŋ AvZ mnŋRB mbv<sup>3</sup> Kiv thtZ cvŋi:

- mgm<sup>v</sup> vPwYzKiY (GLvŋb mgm<sup>vi</sup> Dcw<sup>v</sup> vZ tevSvŋbv nŋ<sup>0</sup>) |
- Z<sup>v</sup> msMh |
- Z<sup>v</sup> weŋkŋY |
- mivK mgm<sup>v</sup> vU mbv<sup>3</sup> KiY |
- mgm<sup>v</sup> mgvavŋbi wefbaevcKí cšvi chŋj vPbv ev hvPvB evQvBKiy |
- mgvavŋbi mŋeŋg cšv vbeŋb ev vbaŋY |
- vbeŋPZ cšv KvŋRi vKiY ev umxvšl ev<sup>v</sup> vevqb |
- umxvšl KvŋRvvi Zv gj<sup>v</sup> vqb |

### **umxvšl tkivb<sup>v</sup>**

umxvšl m<sup>v</sup> vU<sup>v</sup> Avtj vPbv t<sup>v</sup> K Avgiv umxvšlK thš<sup>v</sup> K ev Rational Ges Athš<sup>v</sup> K ev Irrational GB v<sup>v</sup> vŋtM fvM KiŋZ cvii | GQrov, mvBgtbi tkivKiY Avŋvqx Avgiv Programmed ev vbcvqZ ev iavUv umxvšl Ges Non-Programmed ev AvbcvqZ ev Avbaŋi Z umxvšl cvii Pq cvB | Programmed ev iavUv umxvšl nŋ<sup>0</sup> tmB umxvšl hv we<sup>v</sup> vj q cāvŋtK cāZōvb cvii Pvj bvi Rb<sup>v</sup> cāZvbcZ KiŋZ nŋ<sup>0</sup> | G RvZxq umxvšl vZv mbaviYZ we<sup>v</sup> vj ŋi Rb<sup>v</sup> cŋxZ veva vearb ev vbcg Avŋvqx MhY Kŋi vŋKb | thgb- vŋŋKŋ<sup>v</sup> i vŋqZ; eEb, Kvŋ iavUv cŋqb, cvii Pvj bv, mncivvŋgK Kvŋvŋj cvii Pvj bv BZ<sup>v</sup> | G mKj tŋŋ<sup>v</sup> Qrov KLbI KLbI we<sup>v</sup> vj ŋq Ggb cvii vZi D<sup>v</sup> e nq, hLb we<sup>v</sup> vj q cāvŋtK ZvrŋvŋKfite Riav vŋvŋtZ umxvšl MhY KiŋZ nŋZ cvŋi | G aiŋbi umxvšl Avbaŋi Z umxvšl chŋq cŋo | D<sup>v</sup> vniY<sup>v</sup> ŋfc ejv thtZ cvŋi Qvŋ Amŋšl ev evni vMZ mšvŋt<sup>v</sup> i nvjv | GB tŋŋ<sup>v</sup> we<sup>v</sup> vj q cāvŋtK v<sup>v</sup> vŋkZv I mRbkj Zvi gva<sup>v</sup> ŋg mgm<sup>vi</sup> mgvavŋb GvMŋq AvmŋZ nŋe |

weŋkŋÁ<sup>v</sup> i gZvqZ chŋj vPbvŋšl Avgiv Avil KŋqK aiŋbi umxvšl mŋ<sup>v</sup> cvii vPZ nŋZ cvii | G, uŋ nŋ<sup>0</sup> Muddling Through, Mixed Scanning Ges AvakZi MhYthvM<sup>v</sup> A<sup>v</sup> Askx<sup>v</sup> vix umxvšl | Muddling Through umxvšl MhY cvvZŋZ tbZv umxvšl tbb, Zv evZj Kŋib Ges cvivq bZb Kŋi umxvšl MhY Kŋib | G aiŋbi umxvšl MhYi mŋev

<sup>2</sup> Introduction to Educational Administration, P-168.

GB th AbeiZ MhY I ewZtj i dtj mnfRB fŷ imxvšlcwëŧq Averi bZb Kti imxvšl  
tblqv hvq| Zte G aiŧbi MhY I ewZj m=úY©nvZto chŧq cto Ges G t\_ŧK tKvb  
fij dj Avkv Kiv hvq bv| Mixe Mixed-Scanning imxvšl MhY cxwZ m=úY©thšw³K  
Ges nvZto cxwZi gaëZŧGKwJ cšv| GB cxwZtZ thšw³K Ges nvZto cxwZi mŷeav  
Ges fij w`K\_wj MhY Kiv nq| Askx`vix imxvšl Ggb GK aiŧbi imxvšl hv  
we`ij q\_wj tZ euj cŧwZ| whub cŧZöŧbi cäv, wZwb th DEg imxvšl MhY Kiteb  
Ggb K\_v bq| msukó mKtj i mnthwMZvq imxvšl MhY Kitj imxvšl AwKZi e`wbô I  
mwMK nevi m=ŧebv\_vŧK|

GK\_v gtb ivLtZ nte imxvšl MhŧYi tŧŧŧ tkl etj tKvb K\_v tbB| wkŧv wbtq thgb  
wbišl cixŧv wbxŧv Ges MŧelYv Pj tZB\_vKte, tZgub imxvšl MhY wbtq cixŧv  
wbxŧv Pj tZB\_vKte|



**cv#VĚi gj'iqb: 2**

**A) eū ubePbx cĕæ**

mWk DĚi ubt`Rgj-K AŋiuU#K eĚvqZ Kiab| (D`vniY: Avcbvi ubePZ DĚiU K ntj G#K (K) eĚvqZ Kiab)

1. thŠv³K umxvš'ub#Pi tKvbuJi Dci ubfP K#i?  
 K. Z` msM#ni Dci  
 L. Z` we#k#t#Yi Dci  
 M. umxvš'M#Y c#uqvq AbjvZ iuvZ cxvZi Dci  
 N. weKí cšv evQvB Gi Dci|
  
2. umxvš'M#Y c#uqvq tKb mgm'v we#k#t#Y Kiv c#qvRb?  
 K. `#Z umxvš'M#t#Yi Rb"  
 L. mn#R mgm'v mgvat#bi Rb"  
 M. mgm'vi cKZ.KviY L#R tei Kivi Rb"  
 N. mn#R Z` we#k#t#Yi Rb"|
  
3. umxvš'M#Y c#uqvq wevfbaeKí cšv hvPvB Gi KviY uK?  
 K. mWk umxvš'M#Y mnR nq  
 L. mgq Kg j v#M  
 M. LiP Kg j v#M  
 N. Abiqv#m umxvš' t#l qv hvq|

**Av) iPbvj-K cĕæ**

1. D`vniY mnKv#i wevfbaeavc D#j LceR umxvš'M#Y c#uqv e'vL'v Kiab|
2. wevfbaeKvi umxvš'š'i D`vniY v`b|



**mWk DĚi**

A) 1| M, 2| M, 3| K|

**cW 3**

**ve`vj tqi umxvšlMhYi tŋtĪ cāvb ukŋtKi figKv**

**DtĪk**

GB cW tkĪl Avcib—

- umxvšlMhYi tŋtĪ cāvb ukŋtKi figKv DtĪ L KiŋZ cviŋeb Ges
- mWk I KvRi umxvšlMhYi tŋtĪ vZvb ukfvte Zui`vqZ; cvj b Kiŋeb Zv eyŋv I e`vL`v KiŋZ cviŋeb|

GK\_v Ab`Kvth, umxvšlMhYi tŋtĪ cāvb ukŋtKi Kkŋ Zvi Dci ve`vj tqi mvdj` wbfP Kti | Avgiv AvMB tRtbwQ mWk mgŋq mWk umxvšl MhY ve`vj tqi mKj KvRKŋgthgb MwZ I cŋtYi mĀvi Kti, tZgub GKwU fŋ umxvšl KviŋY ve`vj tqi mgr-ŋwZ nŋZ cviŋ | thŋZae`vj q cāvb ve`vj q cŋvmtbi xvl`ŋe`ŋZ Ae`vb Kti b, umxvšlMhYi tŋtĪ Zui`ŋZv Ges Kkŋ ZvŋK meŋcŋv AMŋaKvi w`ŋZ nŋe|

**cāvb ukŋtKi figKv**

t`tki mweR ukŋv velŋq umxvšlMhYi , iæ`vqZ; ukŋv gšŋvj tqi Dci b`v`ll GKvR ukŋv Avā`Bi`vj ukŋv gšŋvj qŋK mnvqZv Kti`\_vŋK| cāvZōvbK chŋq umxvšlMhYi tŋtĪ meŋcŋv , iæzŋe`v`nŋtj b cāvZōvb ev ve`vj q cāvb| Zui`vqZ; umxvšlMhYi Kkŋ Zvi Dci tMvUv ve`vj tqi mvdj` wbfP Kti | ceŋZ`cŋv evj nŋtqŋQ, ve`vj q cāvb GKv umxvšlMhYi bv Kti msukō mnKgŋ`i mnvqZv I gZvŋtZi wfvĒŋZ umxvšl wŋtj tmwU AvāKZi KvRi weteŋPZ nŋe| cāvb ukŋtKŋK gŋb ivLŋZ nŋe umxvšlMhYi ve`vj tqi wewQbetKvb NUbv bq| ve`vj tqi wewfbæmgm`v, NvZcŋZvZ Ges cvi`ūwi K KvRi Avl Zvq GwU Avēi Z Pj ŋZ`\_vŋK|

umxvšlMhYi hvŋZ thšw`K I KvRi nq, tmRb` cāvb ukŋtKŋK KwZcŋq vel q m`ūŋKŋŋ ŋ ivLŋZ nŋe| umxvšlMhYi cŋ`vŋ vZvb wŋtŋe`cŋe`vj i cāv`wŋ t`ŋeb:

1. tK umxvšlMhYi Kiŋeb?
2. tKvb velŋq Dci umxvšlMhYi Kiv nŋe?
3. ukŋmi Dci wfvĒ Kti umxvšl tbl qv nŋe? (GLvŋb umxvšl MhYi msukō wewfbæZ` m`ūŋKŋZvb wPšŋfvebv Kiŋeb)|
4. tKvb c`wZ Aeŋ`b Kti umxvšlMhYi Kiv nŋe?
5. umxvšl m`ŋe` djvŋj uk nŋe?

umxvšlMhYi mWkZv hvPvB Gi tŋtĪ umxvšlMhYi mspvšlGB tPKŋj ÷w cāvb ukŋtKi Rb` mnvqK nŋe|





**cvtVĒi gj`vqb: 3**

**A) eū ubePbx cĕæ**

mĭWK DĒi ūbt`Rgj-K AŋiuUĕK eĒvĭqZ Kiab| (D`vniY: Avcbvi ubePZ DĒiuU K ntj GĕK (K) eĒvĭqZ Kiab)

1. thŠv<sup>3</sup>K I KvĥRi ūm×všĭMĥYKĕĭ cĕvb ūkŋĕKi KiYiq ūK?  
 K. mnKgĕ`i mKtji gZvgĕZi ūfĭĒZ ūm×všĭtbteb  
 L. tKejgvĭ ūmūbqi mnKgĕ`i gZvgZ ūetePbv Kiĕeb  
 M. Z\_`msMĥni Dci ,iæZĭĕeb  
 N. ūm×všĭĭ tPKĭj ÷ AbyiY Kiĕeb|
  
2. tKvb aiĕbi ūm×všĭMĥYi tŋĕĭ ūkŋĕKMY AūaKgvĭvq AvMĥx?  
 K. th mKj tŋĕĭ ūm×všĭMĥY AĕcŋĭvKZ.mnR  
 L. th mKj ūm×všĭĭ tŋĕĭ mgq Kg j vtM  
 M. th mKj ūm×všĭĭ tŋĕĭ ūkŋĕKMY tckvMZ Ávb I AūfÁZvi Ae`vb ivLĕZ cvĕib  
 N. th mKj ūm×všĭĭ Rb` Z\_`msMĥ AĕcŋĭvKZ.mnR|

**Av) iPbvġj-K cĕæ**

1. ūe`ij tqi ūm×všĭMĥYi tŋĕĭ cĕvb ūkŋĕKi fūgKv ūeĕkĭY Kiab|



**mĭWK DĒi**

A) 1| N, 2| M|



## figKv

cw\_exi euf`tk wPivPvi Z ariv Ablyvqx mruuZKKvj chSiki I Ziaw mgvRi ukQvi mruuYtKw`KiY I wqsy cPij Z itqtQ| Ebiesk kZvaxfZ cw\_exi AtbK t`tkB RbmsL`v wQj meP Qovtbr Ges eu`fi BZ`Z wevqB| thvMvthvMi tKvb chP e`v wQj bv| `vbxq `vqZkvmtbi e`v ZLb Mto I tV w| ZLb ivtofi cQ t`tk tKw`qfite we`vj tqi mthvM mjevarki I Ziaw`i KvQ c`vni Z Kiv ntZv| GfiteB cw\_exi Ab`vb t`tki gZ evsjv`tkI `vaxZvceRvtji JcubtemkK Avgvj ukQvi tKw`KiY I wqsy e`v Mto I tV| Kvj mtg ukQvi tKw`KiY I wqsy Avgj vZmsK ntq I tV Ges mugk ukQvi ckvmtbi tqtT D`vi I bgbxq bmvZ MhtYi tqtT cEj wevaxifc AvZcKvk Kti|

`vaxZv DEiKvtj 1974 mtj MWZ evsjv`tki cug ukQvi Kugkb wicvUukQvi tqtT ckvmbK qgZv I KZPZji tKw`KiYtK ukQvi ckvmb e`vi GKw c`vb Iaw etj D`tj Kiv nq| Kugkb Oc`kvmbK qgZv, `vqZi I KZPZK wefvMxq I tRjv Ges gva`ngK `t`ii Dctii chiqi ukQvi cZovbmgfni tqtT h`v c`qvRb I h`vm`e ukQvi cZovb wfiE`Z wefKw`KiY KitZ nte0 etj ZvM` c`vb Kti| evsjv`tk GKw MYgax, cMwZkxj I h`MvcthvMx ukQvi e`v Mto tZjvi j`q` miKvni I temiKvni chiq wefKw`KiY ch`t` eu tmvgbvi wmt`uvwRqvg ntqtQ Ges wevfbemYgva`tg we`li Avtj vPbv ntqtQ| miKvtii Zid t`tk G e`vcvfi BtZvgta` tek wKQy, iazcy`wmxvsl` tbqv ntqtQ Ges tm`tjvi ev`evqbl ntqtQ| GB BDibU`i cug cvtV tKw`KiY I wefKw`KiYi msAv I wqvgK mruuYtK`Avtj vPbv Kiv ntqtQ| wZxq I ZZxq cvtV h`vmtg tKw`fZ ckvmb I wefKw`fZ ckvmtbi mjev-Amjev mruuYtK`Avtj vPbv Kiv ntqtQ|

cvV- 1: tKw`fZ I wefKw`fZ ckvmb

cvV- 2: tKw`fZ ckvmtbi mjev-Amjev

cvV- 3: wefKw`fZ ckvmtbi mjev-Amjev





**ewn`K KviY**

ewn`K KviY, ij i gta` cto c&vmtb RbM#Yi AskMh#Yi c&qvRbxqZv, RbM#Yi mjeav-  
Amjeav m#utK@m#PZbZv Ges `vbxq Ae`v I ivR%buzK P#tci m#t\_ b#uz I Kg#Pi  
mg#SvZvKiY BZ`w` | Gme weiq t`#K D`mZ mgm`v, ij m#aviYZ `vbxqf#teB m#jvrv  
Kivi c&qvRb nq| G mKj t#t#` #lgZv we#Kw` KiY Qvov tKvbiKg Dcvq `v#K bv|

**eisj v`tki ik#lv c&vmb: tKw`fZ bv we#Kw`fZ?**

Avgt`i ik#lv c&vmtb m#ePP I me#bg#ch#q chS#we#fb#e#vc ev`li it#tQ| Avgt`i  
gva`igK ik#lv c&vmtbi c&Z `w#cvZ Kitj Avgiv #bg#j #LZ c&vmtbK `li m#gr` t`L#Z  
cvB|

**eisj v`tki gva`igK ik#lv c&vmb**

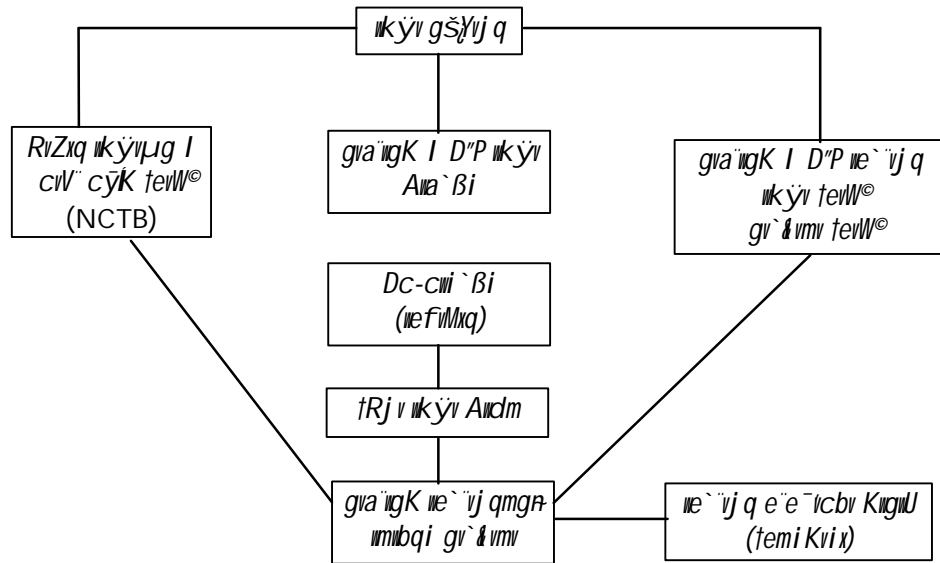

Avgt`i t`tki gva`igK ik#lv c&vmb tKw`fZ bv we#Kw`fZ Zv w`i KitZ ntj  
Avgt`i t`L#Z nte ik#lv m#v#KZ we#fb#e#lgZv c&vmtbi tKvb `li c&qvM KitQ| ik#lv  
cwi K#i#v Ges ik#lv ev#RU #K c#q#b KitQ? Gme ik#lv gS#y#j qB c#q#b I Kv#Rix  
K#i | GRb` tKvb tKvb mgq we#kl tKvb ms`v Mv#v Kiv ntj I Zv ik#lv gS#y#j t#iB  
#bq#t#Y KvR K#i `v#K| cv`m#P I ik#lv#ug c#q#b, cyK c&vkv#v I mieiv#v BZ`w`  
KvR I ik#lv gS#y#j t#i #bq#t#v#x#v RvZxq ik#lv#ug I cv`cyK teW`K#i `v#K| K`v#v#v  
m#v#v#v (ik#lv) c&Z#bi ci c&vmtbi EaZb `v#qZc#e` m#gr` n#Z m#Kvix c&v#v ik#lvK  
chS#c`m#gr`#n t#vK #b#q#v#v, P#v#v#v BZ`w` me#KQ#B K#i ik#lv gS#y#j q| Zv ntj t`Lv  
h#t`Q th c&q me #lgZv#v gS#y#j q m#v#v#v A`ev A#x#v` Ab`v#v` m#P ms`v I cwi`B#i i  
gva`igB c&qvM K#i `v#K| G#b#v#v we#fb#e`ij t#i M#v#v-U-Bb-GBW, ik#lv f#v#v, D`PZi  
ik#lv#v Rb` Av#v#v teZb e#x#v BZ`w` th mKj KvR G h#v#v we#v#v#v cwi`B#i i `v#qZj  
#Qj tm me KvR Av#v#v#v X#v#v` Av#v#v B#i i A#x#v#v #b#q h#v#v q#v#v#v#v| Zv#v we#v#v#v ik#lv  
cwi`Bi t`#K Av#v#v#v#v #b#qZg `li chS#we#fb#e#c&vmtbK av#v#v i`ay`b#v`b i#v#v

ᄃ Ae GW#Kkb

KvRB Kti hv"Q| Gme wePbv Kti t`Lv hvq evsjv`tki gva`ugK uk`qv ckvmb tKw`fZ uk`qv ckvmbiB DrKó.D`vniY|

wbtgæc0É PttU©c0\_ugK uk`qv ckvmb KvVtgv c0Z j`q Ki+j I t`Lv hvq mtePP uk`qv gšYj q t`tk mefbgame`vj q chSfAfbK,uj`li itqtQ|

### evsjv`tki c0\_ugK uk`qv ckvmb

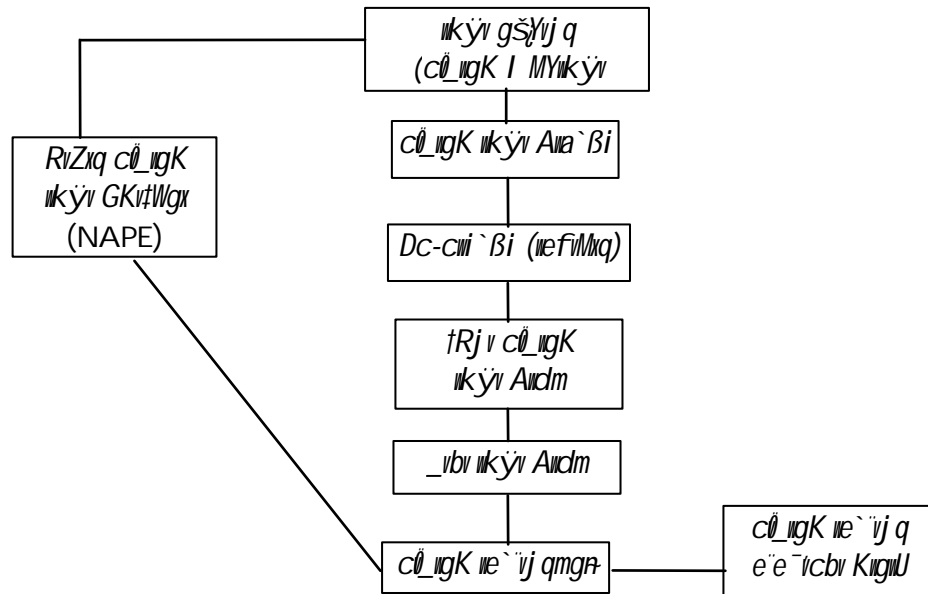

GLv#bl gj- qgZv uk`qv gšYj q I c0\_ugK uk`qv Awa`BtiB mxgve x| gva`ugK uk`qvi gZ c0\_ugK uk`qvi t`q`fI evtRU c0`qb, cwiKibv I c0K c0`qb, cvV`mup I uk`qvµg c0`qb, cvW`cyK c0`kvbv I mieivn, ckvmbi EaYzb`ti tjvK wbtqwm I Zvt`i PvKwi weia c0`qb BZ`w` mKj qgZvB c0`q ev ctivqfite uk`qv gšYj tqi nvtZ| G Ae`v wePbv Kti AwaKzi qgZv wefKw`KiYi j`q` 1981 mvtj GK Aa`v`tk ZrKvj b gnKgv chiq`vbxq`ᄃ KZE`q Mvb Kivi K\_v uQj| cieZP chiq ckvmbK qgZv wefKw`KiY Kiv ntj beMwZ DctRjv cwiI`tkB`vbxq c0\_ugK uk`qv`vqZ; AcP Kivi K\_v w`i Kiv nq| ukS`DctRjv cwiI`mgn AvR chSf`h\_vh\_fite MwZ bv nl qitZ G e`e`v mwK ifc cwiMh KiZ cvi`q bv| G KviY c0\_ugK uk`qv ckvmb GLbl euj c0`vukZ wefKw`KiY h\_vh\_fite msNwZ ntZ cvi`q bv|



**cv#V#Ei gj`vqb: 1**

**A) e# ubePbx c#æ**

m#WK D#Ei ub#`Rgj-K A#i#U#K e#v#qZ Kiab| (D`vniY: Avcbvi ube#PZ D#Ei#U K ntj G#K (K) e#v#qZ Kiab)

1. tKv#U we#K#`fZ c#v#t#bi `enkó?
  - K. Aa`b Avdm KZR.Dci`Avd#mi #m#v#šKvhRixKiY
  - L. #lgZv c#v#t#bi m#e#P`#i b`KiY
  - M. #lgZv`vbxq KZE#t#i ubKU b`KiY
  - N. tK#`i #m#v#š#ev ub#`#ki Rb`c#Z#v#vKiY|
  
2. P#j # I q#\_# g#Z we#K#`Ki#Yi c#v#b Dcv`vb tKv#U?
  - K. #m#v#š#M#Y
  - L. c#v#b
  - M. mgm`v tgvK#tej vKiY
  - N. `v#qZ;Ac#|
  
3. tKv#U #lgZv we#K#`KiY#K Acv#v#h#K#i tZvtj?
  - K. Ea#Zb KZE#t#i ubKU`vq#Zv
  - L. `#Z Kvh#m#úv`#bi Pvc
  - M. RvZxq H#K`i c#qvRb
  - N. GKB iKg b#v#Zi c#qvRb|

**Av) m#v#B D#Ei c#æ**

1. tK#`fZ c#v#b ej #Z #K tev#vq?
2. tK#`KiY-we#K#`Ki#Yi m#v#\_ #m#v#š#M#Y #lgZvi m#úK#Ki#?
3. tK#`KiY-we#K#`KiY uba#i#Yi t#i#i` , i#Z#Y#KviY , t#v#K?
4. c#v#b we#K#`Ki#Yi e#v#K KviY , t#v#K?



**m#WK D#Ei**

A) 1| M, 2| K, 3| L|

**cW 2**

**ტკუ`ფზ ცკუმტი მუეავ-ამუეავ**

**დტიკ**

GB cW tkʼl Avcib—

- ტკუ`ფზ ცკუმტი მუეავ eYᅇv KiʼZ cviʼeb Ges
- ტკუ`ფზ ცკუმტი ამუეავ Dʼj ᅇ KiʼZ cviʼeb|

**ფიგკv**

ტკvb ტკvb ტʼʼᅇ thgb Riʼai Kvj ᅇb Ae`vq ev Dbᅇbgj-K KgRvʼU ტკუ`ფზ ცკუმტი i f cʼve j ᅇ Kʼi AʼbʼK Gi ᅇ iazʼK EʼaYʼZʼj aʼiʼQb, Avevi AʼbʼK GʼK GKU MYZwšK tʼʼki cʼvmb e`e`vq Agʼj Ki bq etj AwfgZ wʼtqʼQb| Gʼʼᅇ UʼKwʼfʼj i (De Tocqueville) gšʼu j ᅇ Yʼq| wʼzib Zui eʼʼte` ტკუ`ფზ e`e`vi RqMvbl tMʼqʼQb, mʼt\_ mʼt\_ Avevi mgvʼj vPbvI Kʼi tMʼQb| Zui gʼZ kwʼKvj x ტკუ`ფზ e`e`v e`ZxZ Rvzi DbwZ I cʼwz mʼe bq Ges Rvzi Aw`Zj| wʼtK `vKʼZ cviʼi bv| Avevi GI mZ` th ტკუ`ფზ ცკუმბ RvziʼK `ᅇᅇ KiʼZI mgwaK mʼʼg| “Indeed I can not conceive that a nation can live and prosper without a powerful centralization of government. But I am of opinion that a centralized administration is fit only to enervate the nation in which it exists by incessantly diminishing their local spirit . . . .” Avgiv eZᅇvb cviʼv ტკუ`KiʼYi, wʼtʼkI Kʼi wʼKʼv cʼvmb ტკუ`KiʼYi მუეავ-ამუეავ mʼuʼKʼRvbʼZ tPóv Kie|

**ტკუ`ფზ ცკუმტი მუეავ**

ტკუ`ფზ wʼKʼv cʼvmbi ტʼʼᅇ wbgw ᅇLZ მუეავ, wj i K\_v Dʼj ᅇ Kiv hʼq:

**1. RvZxq wʼKʼv wʼz wbaʼY**

wʼKʼv GKU RvZxq ᅇ iazʼcʼwʼelq| G wʼelʼq ZvB GKB RvZxq bʼwz MʼY tMvUv Rvzi `w\_ B cʼqʼRb| ტკvb ტკvb ტʼʼᅇ wʼKʼvʼK RvZxq HʼK`i evnb wʼmʼvʼte t`Lv nq| RvZxq HʼK`i `w\_ RvZxq wʼKʼv wʼz wbaʼY Kiv ტკუ`ფზ wʼKʼv cʼvmbi cʼʼB mnR| Kvi Y ტკუ`ფზ wʼKʼv cʼvmbB miv tʼʼki wʼKʼvi GKgvʼ wʼbqšK I G wʼelʼq GKgvʼ wʼmʼvš MʼYKvi x|

**2. ᅇwʼetiva wimb**

ტკუ`ფზ wʼKʼv cʼvmb wʼKʼv wʼelqK mKj ᅇgZv GK Ges mʼeʼP `ʼi `vʼK| dʼj cʼvmbK HK` wʼwʼZ nq| tK>`a I AʼAʼj ev wʼwʼbʼwʼAʼAʼj i gʼa` bʼwz wbaʼY I tmme KivRixKiʼY gZʼwʼZvi AeKiv Lᅇ Kg| ᅇgZvi Avl Zv I GLwZqvi wʼbʼqI wʼgZ ev wʼetivʼai ტკvb AeKiv `vʼK bv| ᅇgZv GK tKʼ>`a `vʼK etj ტკუ`ფზ ცკუმბ mKj A`uóZv, ᅇwʼetiva I Sʼtʼgʼv gʼ|







**8. TãlcY@m×všŷi mætebv**

ejv nŷq \_vŷK th tKw`fZ ukŷv cŷvmb `ãZ um×všŷi ubŷZ mŷŷg nq| KviY G weŷq tK>`ŷK Aŷb`i gŷvŷcŷŷx nŷq \_vKŷZ nq bv| ukŠ`ev`ŷe `ãZ um×všŷi me v`ŷKi LjŷbŷvU mKj weŷq mŷvKfŷŷe weŷePbvq AvbŷZ mŷŷg nq bv| dtj tKw`fZ ukŷv cŷvmbŷbi Kŷ\_Z `ãZ um×všŷiãvšŷŷt\_ŷK thŷZ cvŷi |

**cvŷVvËi gj`vqb: 2**



**A) eü ubePbx cŷæ**

mŷvK DËi ubŷ`Rgj-K AŷŷiUŷK eËvŷqZ Kiab| (D`vniY: Avcbvi ubeŷPZ DËiU K ntj GŷK (K) eËvŷqZ Kiab)

1. tKw`fZ cŷvmbŷ j vj wdzvi t`ŠivZŷteto hvq tKb?  
 K. mKj um×všŷŷtK>`ãt\_ŷK tbi qv nq etj  
 L. cŷŷvRbxq um×všŷŷMŷY I ubŷ`R cŷvŷb wej æ`NŷU etj  
 M. fvi mvg`bŷvZ j v`NZ nq etj  
 N. `ZtÛZ@mŷthŷvMZvi Afve \_vŷK etj |
  
2. tKw`fZ cŷvmb bŷbv `ŷ\_P tj vK I tMŷvŷi Pŷŷci evBŷi \_vŷK etj tKŷvU mæ nq?  
 K. cŷfŷegŷ cŷvmb  
 L. `ãZ um×všŷŷMŷY  
 M. Ø>`-weŷŷiva ŷbi mb  
 N. e`q mŷŷKvPb|
  
3. tKw`fZ cŷvmbŷ t`QvPŷvi Zv t`Lv t`qvi Avk¼v \_vŷK tKb?  
 K. SvbyAvgj viv um×všŷŷMŷY Kŷi etj  
 L. ivR%bŷvZK, mvgŷvRK ev bŷbv tMŷvŷi Pŷŷci evBŷi \_vŷK etj  
 M. tK>`ã`bŷvZgŷ bq etj  
 N. tKŷ`ŷ um×všŷŷAb`vŷŷ`i cŷŷŷ Aek`gvb` etj |

**Av) msŷŷŷB DËi cŷæ**

1. tKw`fZ cŷvmbŷ e`q mŷŷKvPb nq tKb?
2. tKw`fZ cŷvmbŷ `ŷŷ cŷi Kŷi bv I um×všŷŷMŷY mæ nq tKb?
3. tKw`fZ cŷvmbŷi cãvb KŷqKŷv Amŷæavi Dŷj L Kiab|



**mŷvK DËi**

A) 1| L, 2| K, 3| N|





## 2. mgštqi Afve

weifbæAAj wBR wBR wetq ᄡaxb| wetKw`fZ wkŋv cŋvmb Zviv iay`xq ᄡ\_P AbKj  
KgmP MhY Kti ᄡtK, weifbæAvAj K KgmP I Kgexwi Zi gta" mgštqi Afve  
cwi jwŋZ nq| KviY GK\_v meRbMh" tKw`q ms`v Qvov Ab" Kvi I cŋŋ GKvR Kiv  
mnR bq|

## 3. A`ŋ I SŋKcY@KgmP

wetKw`KiY ZLbB mdj I mv`R ntZ cŋti hLb AvAj K Kvŋŋ q, wj tZ `ŋ I AwfA  
tjvtK tKvb Afve ᄡtK bv| cwí Kí bv cŋqb I Zv ev`evqb eo RwJ I tUKwK`ij  
KvR| AwfAZv bv ᄡKtj, wetKlÁ bv ntj G KvR mgvav Kiv KwB ntq `wvq| Avgt`i  
gZ Dbqbkj t`tk wetklÁi tek Afve itqtQ| Gt`i teZb I Ab`vb" `vexl tewk|  
GKgv tKt`i cŋŋB nqZ AwfA tjvK I D`Pe`tq t`kx wet`kx wetklÁ ivLv mæe ntZ  
cŋti, AvAj K ms`vi cŋŋ bq| ZvB AvAj K ms`v KZR. MpxZ cwí Kí bv I KgmP  
A`ŋ I SŋKcY`nevi Avk¼v ᄡtK|

## 4. tMvôx`ŋ\_P wKvi

AvAj K ms`v, tjv mKtj i nvtZi KvQB ᄡtK| G, tjv tKt`i gZ AZ`ti bq, AZ  
kw³kvj xl bq| Avevi tKt`i gZ weifbæ`ŋ`I tMvôxi Pvc t`tK cŋzi ŋvi Dcvq|  
Zvt`i Kg| ZvB `vbxq cŋvmb mnRB kw³gvb tMvôx I `tj i Pvtci wkKvti cwí YZ ntZ  
cŋti | G Kvi tY wetKw`fZ wkŋv cŋvmb AŋB mgq Rb`ŋ\_P cwí etZ`Mvôx`ŋ`KvR  
KtZ eva" nq|

## 5. e`qeúj

wetKw`fZ wkŋv cŋvmb gvŋb GK tKt`i cwí etZ`eú tK`ª; eú Awdm Ges eú KgPvix|  
Gt`i Rb" `iKvi AŋB UvKv, teZb fivZv, Ni fivov, t÷kbvix LiP BZ`w | AZGe  
wetKw`fZ wkŋv cŋvmb `fveZB GKwU e`qeúj KvR|

## 6. wej wZ wmxvšl

RvZxq Rxeŋb AŋB mgq bvbv Riwi mgm`v t`Lv t`q| AŋB mgq RvZxq AMwzi `ŋ`  
Riwi wfiÉtZ KgmP MhY Kiv `iKvi ntq cŋo| wetKw`fZ wkŋv cŋvmb G atŋbi  
cwí w`wZ tgvKvtejv KtZ mg`nq bv| KviY ŋgZv I `wqZj AŋB tKt`ª wef³ ᄡtK  
etj Zvt`i mKj tK`æZ KvR D0y Kti, Avtj vPbv Kti cwí Kí bv MhY Kiv mnR nq bv|



**cvřVĚi gj`iqb: 3**

**A) eú ubePbx cĕœ**

mivK DĚi ubř`Rgj-K AŋiuUřK eĚvıqZ Kiab | (D`vniY: Avcbvi ubePZ DĚiU K ntj GřK (K) eĚvıqZ Kiab)

1. tKıbuUřK weřKıv`řZ cĕvıřbi mıřav unıvıře weřePbv Kiv hvq bv?  
 K. `bıřZK kıv<sup>3</sup> I gřbvej eıř  
 L. MYZvıřřKZv  
 M. mgřřq mıvab  
 N. Kıhřvi nıvı|
  
2. weřKıv`řZ cĕvıřbı RıvZıq bıvıř ubařřıY cĕZeÜKZı ř`Lv ř`q řKb?  
 K. weıřbıřAAj ubřřıř`ı weřePbv gZ bıvıř ubařřıY Křı etj  
 L. AvĀıj K KgřřZř`ı `řaxbZı\_vřK etj  
 M. bıbv řMıvıř `ř`ř`řıkKıvı nq etj  
 N. A`ř I SıKcYřKgmıřP MıřY Křı etj |
  
3. weřKıv`řZ cĕvıřbı mıgvıřK AMıřıřZ Zi vıřř nq řKb?  
 K. KgřřZřKgmıřıř`ı `bıřZK kıv<sup>3</sup> I gřbvej eıř cvq etj  
 L. jıj ıdZıvı ř`řıvZřnıvı cvq etj  
 M. Kıhřvi nıvı cvq etj  
 N. cıřřıvı bıřřıvı gıv`tg mRbıřıj cĕZřvı weKıvK NřU etj |

**Av) msıřıř DĚi cĕœ**

1. weřKıv`řZ ıřKřıvı cĕvıřbı mıřj eYřıvı Kiab|
2. weřKıv`řZ ıřKřıvı cĕvıřbı Křıj ıj Lıř|
3. řKıv`řZ ıřKřıvı cĕvıřbı I weřKıv`řZ ıřKřıvı cĕvıřbı gřa` řKıbuU Avcbvi weřePbvı AıvıKZı MıřYřıvıM`? hıřř` ıř b|



**mivK DĚi**

A) 1| M, 2| K, 3| N|

## figKv

čkvimbK űűqvKj vtc KZŹjAcŹ (Delegation) GKűű eűj Avtj űPZ űelq| th tKvb epr msMVtb čűqkB KZŹjAcŹ ev n`lšfi nŹZ t`Lv hvq| űŹž<sup>a</sup> msMVtb űŹgZv űefvRtbi (Division of Labour) ev KZŹjAcŹyi čűqvRbxqZv Ly GKUv tbB ej tjb PŹj | űKš<sup>a</sup> msMVbűű hűű űekvjvKvi aviY Kti űKsev Zvi čűűű űe`űZ jvf KiŹZ \_vtK ZLb KZŹjAcŹyi űelqűű űižcŲ<sup>o</sup>nŹq IŹV| KviY, űekvj msMVtbi KYűűi űntmte GKRB e<sup>ir</sup> ev űű KŹqK e<sup>ir</sup> i čŹű mKj űelŹq űm<sup>x</sup>všMűY Kiv I Zv ev`űvqb Kiv Am<sup>e</sup> nŹq čŹo| KLbB me űelŹq űm<sup>x</sup>všMűY Kiv `xNŹvj aŹi Zvi čŹű m<sup>e</sup> nq bv| dj kűZŹZ, KZŹ<sup>e</sup>i mŹű űŹgZv I `űŹqZj Aek`B űefvRZ nŹq čŹo| KZŹjAcŹB nj tmB űŹgZv I `űŹqZj eĚtbi DchŹ Dcvq ev gűa`g| űekvj GKűű msMVtb ZrciZvi mŹű čkvimb Kvh<sup>o</sup>Pij vŹZ nŹj I msvMvbK DbűZ űeavb KiŹZ nŹj tmLvŹb Aek`B KZŹjAcŹ e<sup>e</sup>vi čűqvM ev AbűűiY \_vKte|

GB BDibŹU KZŹjAcŹyi űefvRbűű K m<sup>e</sup>űŹK<sup>o</sup>avi Yv čűvŹbi jŹűű űZbűű čvV műbŹek Kiv nŹqŹQ| čvV űjv nj űbgűŹc:

- čvV- 1: KZŹjAcŹyi msÁv I tŹűűűefvM
- čvV- 2: KZŹjAcŹyi műűav, čŹZeŪKZv I bűűZgij v
- čvV- 3: `vbxq űKŹűv KZŹ<sup>e</sup>ŹŹi figKv

**cW 1**

# **KZŹ;AcŲyi msÁv I tkŲŲefVM**

## **DŲik**

GB cW tkŲI AvcŲb—

- KZŹ;AcŲ ej ŲZ ŲK tevSvq Zv ej ŲZ cviŲeb;
- KZŹ;AcŲ I ŲetKŲ`KiŲyi gŲa` cv\_Ŕ` ŲbŲfcY KiŲZ cviŲeb Ges
- KZŹ;AcŲyi tkŲŲefVM DŲj L KiŲZ cviŲeb|

## **KZŹ;AcŲyi msÁv**

GKŲU Ųe`Z.I RŲUj msMVbŲK `ŲŲZvi mŲŲ\_ KvR KiŲZ nŲj tmLvŲb KZŹ;ev ŲŲgZv AcŲyi cŲŲvRbxqZv Ų`Lv Ų`q| ŲKvb msmVŲbi EaŲŲb KgŔZŲ KZŔ. Aa`b KgŲixŲ`i gŲa` KŲhŲmŲuv`Ųbi cŲŲvRbxq `ŲŲqZj I ŲŲgZv AcŲ Kivi cŲŲZŲK KZŹ; AcŲ ej v nq| gŲŲ (Mooney)i fvlvq KZŹ;AcŲ nj EaŲŲb KZŔŲ KZŔ. Aa`b KZŔŲŲi ŲbKU mŲŲw`Ų ŲKQyKZŹ; AcŲ| "Delegation means conferring of specified authority from a higher to a lower authority." Gi dŲj Aa`b KgŔZŲev KgŲix Zvi ŲbKU n`ŲŲŲi Z ŲŲgZv cŲŲvM ev ŲfvM Kivi AvBbMZ AbŲŲZ cŲŲ nb hŲ I ŲZŲb EaŲŲb KZŔŲŲi AaxŲb ZLb KgŲZ `vŲKb| ŲUŲi (G.R. Terry) Aek` gŲŲ-i e`vL`vi mŲŲ\_ ŲfbŲZ ŲcvlY KŲib| ŲUŲi-i gŲZ KZŹ;AcŲ nj ŲŲGK ŲbeŲŲ ev msMVb-BDŲbU nŲZ Ab` Avi GK ŲbeŲŲ ev msMVb-BDŲbŲUi ŲbKU KZŹ; cŲŲb| "Delegation means conferring authority from one executive or organisation unit to another."

msMVŲbi KZŹ;AcŲ KvŲŲ cŲŲvŲbK bŲŲZgŲj vi ŲŲbqŲŲ cŲi ŲaŲ (Span of Control) bŲŲZ AbŲŲi Y KŲi ŲŲj | KZŹ;AcŲyi A`GB bq th AcŲKvix KZŔŲŲi cŲŲ ŲŲŲK mKj `ŲŲqZj Z`ŲM Kiv nŲŲŲQ ev ŲovŲŲ ŲŲgZv n`ŲŲŲi Kiv nŲŲŲQ| cŲKZ.AŲ`KZŹ; AcŲyi ŲŲŲŲ KZŹ;AcŲKvix KZcŲŲ ZŲi ŲŲgZv I `ŲŲŲZj ŲKQyŲw`Ų Ask AcŲ KŲi `vŲKb| ŲZŲb ZŲi AaxŲb KZŹ;MŲŲYKvix KZŔŲŲK cŲi`kŲ, ZŲŲeavb, ŲbqŲŲ Ges chŲŲŲŲyi ŲŲgZv aŲi ivŲLb| Ggb ŲK ŲZŲb ZŲi KZŹ;AcŲ th ŲKvb mgq evŲZj ev cŲŲ`vŲvi KŲi ŲbŲZ cvŲib Ges ŲbŲŲi nŲŲZ cŲŲivq mg`ŲŲŲgZv b`ŲKiŲZ cvŲib| KvŲRB KZŹ;AcŲyi `ŲŲ `enkŲ`j ŲŲ Kiv hvq| GKŲU nj, EaŲŲb KZcŲŲ ŲbŲŲi B`QvŲŲvqŲ th ŲKvb KvŲŲŲ `ŲŲqZj Aa`b KZŔŲŲi ŲbKU b`ŲKiv Ges AcŲŲU nj Aa`b KZŔŲŲK ZŲŲeavb I cŲi`kŲ Kiv|

## **KZŹ;AcŲ I ŲetKŲ`KiŲyi gŲa` cv\_Ŕ`**

ŲetKŲ`KiY I KZŹ;AcŲ AvcŲZ`ŲŲZ GKB iKg etj gŲb nŲj I DŲŲŲi gŲa` hŲ\_Ų cv\_Ŕ` iŲŲŲQ| Aek` GB cv\_Ŕ`ŲU cŲi gŲŲMZ| ŲetKŲ`KiY nj KŲhŲmŲuv`Ųbi Rb` ŲŲgZvi cŲŲn`ŲŲŲi KiY| Avi KZŹ;AcŲ nj ŲŲgZv ev `ŲŲŲZj ŲKQyŲw`Ų AŲŲki



n`lsh KiY| A\_# GLv#b Aa`b KZEግ EaYጌb KZEግግi GtR:U ev cZubwa intmte  
KivR Kti \_v#K| EaYጌb KZEግ Aa`b KZEግግi Dci wbt`R I Avt`k Rvix Kivi I  
wmxvšlcbtcixግግv Kivi ግገZv mKj mgqB ati ivtL| mstግግc ejv nq, "What is  
ceded is merely functions and not authority and responsibility." mZivs  
wetKw`KiY nj KZጌ;Acግ A#cግግv tenk ግገZv I `wqZ;Acግ|

### **KZጌ;Acግግi tkwiefull**

KZጌ;Acግ ግayEaYጌb KZEግግi wBKU t\_#K Aa`b KZEግግi wBKU nq bv, wbgwli  
t\_#K D`P`ti KZEግግi wBKU n#Z cvti, Avevi mg`ti KZEግግi gta`l n#Z  
cvti| mZivs KZጌ;Acግ wZb tkwiyi n#Z cvti, h\_v (1) wbgwfglyx (Downward),  
(2) DaYwfglyx (Upward) Ges (3) cvkfwfglyx (Sideward)| wbgwfglyx KZጌ;  
Acግግi ግግግi EaYጌb KZEግ wbgzጌ KZEግግi wBKU KZጌ;Acግ Kti \_v#K, thgb  
cåvb wግግK Zui Aaxb`ImnKvix cåvb wግግግi wBKU KZጌ;Acግ Kti b| EaYwfglyx  
KZጌ;Acግ ej #Z eSvq wbgzጌ KZEግ KZR. Zui EaYጌb KZEግግi wBKU KZጌ;  
Acግ, thgb- wግግKe, Zui KZጌ; wግግK mwguzi mfvuzi wBKU Acግ Kti  
\_v#Kb| cvkfwfglyx KZጌ;Acግግi tejvq KZጌ;mgchግግi KZEግግi gta`n`lsh Z  
n#q \_v#K, thgb Awa`Bti i Dc-cwi Pvj K ckwmb-Gi KZጌ;Dc-cwi Pvj K ckwግግY-Gi  
wBKU Acግ|

KZጌ;AcግግK gvIv ev cwi gvYMZ w`K t\_#Kl KtqKw tkwytZ fVM Kiv hvq| G\_#jv  
nj, (1) AvbግmbK ev AbvግmbK (Formal or Informal), (2) cYev AvsukK (Full  
or Partial), (3) kZጌaxb ev wtkZግ(Conditional or Unconditional) Ges (4)  
cZግግ ev ga`eZግ(Direct or Intermediate)| AvbግmbK KZጌ;Acግግi ግግግi KZጌ;  
Acግ mawukZ weva, cåva I Avt`kvewj wj wLZ AvKviti mibtek Kiv n#q \_v#K|  
cግግvšti AvvግmbK KZጌ;Acግ cግግ Z ixwZ, cግግ I mg#SvZvi wfiEtZ msNuUZ n#q  
\_v#K| EaYጌb KZEግ hLb tKvb Aa`b KZEግግK Ggbfvte KZጌ;Acግ Kti th  
Aa`b KZEግ tKvb Kvhmuv`b, Pw`muv`b ev Avjvc Avtj vPvri cYግግZvi cግqvM  
Ki#Z mግግ nq, ZLb Zv#K cYግKZጌ;Acግ ejv n#q \_v#K| wKs`Aa`b KZEግግK  
hw` Kvhmuv`b, Pw`muv`b ev Avtj vPvri tKvb chግግ EaYጌb KZEግግi Dct`k I  
wbt`Rbv Mh#Yi Rb``vqex \_v#KZ nq, ZLb AvsukK KZጌ;Acግ Kiv n#q#Q etj  
AvfwnZ Kiv hvq| KZጌ;Acግ kZጌaxb nq hLb Aaxb`lKZEግግi wuqvKjvc EaYጌb  
KZEግግi chግግY I Ab#gv`#bi A#cግግvaxb \_v#K| wKs`Aaxb`lKZEግግi hw` Zvi  
wuqvKjvc tKvbiKg msiግግ e`wZti#KB gግfvte muv`b Ki#Z cvti, ZLb Zv#K  
wtkZግKZጌ;Acግ ejv n#q \_v#K| cZግግ KZጌ;Acግግi ግግግi KZጌ;Acግ mawukZ  
cግግ ግግi gv#S tKvb ZZxq cግግ ev e`w` \_v#K bv ev n`ግግc Kti bv| ga`eZግKZጌ;  
Acግ K`wPr n#q \_v#K| Avgv`i t`#k RbM#Yi tfvU wbePZ mism`MY KZR.  
cåvbgšx I ivocåvb wbePb Gi cKó.D`vniY|





## KZĚ;AcŕYi cĚZeÜKZv

KZĚ;AcŕYi tĚĚĚ KZK,uj cĚZeÜKZv t`Lv wĚZ cvĚi th,tjv cĚvbZ `B aiĚbi nĚq \_vĚK, thgb- mvsMvĚK cĚZeÜKZv Ges e`w³MZ cĚZeÜKZv|

### **mvsMvĚK cĚZeÜKZv**

mvsMvĚK cĚZeÜKZv bvbvřĚ t`Lv wĚZ cvĚi| cĚgZ, tKvb mvsMvĚb cĚZwĚZ c\_xwZ I KvhĚĚj xi Afve \_vKĚj KZĚ;AcŕYi Kvr mnR I Zi wšZ nĚZ cvĚi bv| wĚZxqZ, mgšĚ I thvMřthvM gva`ġi Afve \_vKĚj I KZĚ;AcŕYi cĚ\_ cĚZeÜKZv mġo nĚq \_vĚK| ZZxqZ, msMvĚbi AvKvi I Ae`vbi KZĚ;AcŕYi cĚ\_ GKwU cĚZeÜK| mvsMvĚb ep`vKvi Ges AĚj wřwĚK me`Z.bv nĚj KZĚ;AcŕYi mel qwU weĚkl \_i aĚj;ciq bv Ges AcŕYi KvrwU mnR nq bv| G,tjv Qvov AvI GKwU mel q KZĚ;AcŕYi cĚZeÜK wntmĚ Kvr KĚi \_vĚK| tKvb tKvb cĚvmĚKi exgj- aviYv \_vĚK th, KZĚ;wbĚRi nĚZ aĚi bv ivLĚj mgMšmsMvĚw LÜ-meLÜ nĚq hvĚ| D`PZi cĚvmĚKĚi ġġb GB aiĚbi ġig thvM`Zvřeva Ges Aaxb`Ě`i thvM`Zv mġuĚK®mskq KZĚ;AcŕYi cĚ\_ GKwU meĚ³⁄₄bK cĚZeÜK|

### **e`w³MZ cĚZeÜKZv**

e`w³MZ KviYI KZĚ;AcŕYi cĚ\_ cĚZeÜKZv mġo KĚi \_vĚK| Gme e`w³MZ KviY,tjv nj h\_vġġg- KZĚ;ĚK aĚi ivLĚZ AvZcĚksmv, RbMĚYi `wġi mvgġb we`gvb \_vKvi Ges mg`lvKQy Rb` ab`ev` I cĚksmv cvl qvi tbkv, Aaxb`Ě`i cĚĚ t\_ĚK AvbM`Z`nxbZvi fq, mnřthvMĚ`i ewx I thvM`Zv mġuĚK®Av`vi Afve Ges RbMY I D`PZi KZĚ;ĚĚi wĚKU Revew wZv I `vqexZvi fq BZ`w |

Dchř mvsMvĚK I e`w³MZ mel qveġj KZĚ;AcŕYi cĚ\_ cĚZeÜKZv mġo KiĚj I th tKD wbtmĚ`tn `xKvi KiĚeb th, msMvĚb `ĚĚv ewx I MvZKvj Zv Avbqġbi Rb` KZĚ;AcŕYi e`e`v \_vKv evĚbřq| G Rb` KZĚ;AcŕYi cĚ\_ D³ evav meĚĚ, Ěj vĚK h\_vmĚe` ġřfZ Kiv cĚqvRb|

## KZĚ;AcŕYi bwxZgvj v

KZĚ;AcŕYi h\_vh\_ cwi KĚi bv cĚvmĚbi Kvg` Dbqġ Avbqġ KiĚZ mrvh` KĚi \_vĚK| KĚĚRB KZĚ;AcŕYi hvĚZ KvhŘi I mv\_Ř nq tmw`ĚK weĚkl `wġ t`qv cĚqvRb| KZĚ;AcŕYi tĚĚĚ wĚġġc wKQybw`Ě mvari Y bwxZ Abyři Y Kiv evĚbřq|

- KZĚ;AcŕYi mġbw`Ě I wġ wLZ nI qv DvPZ|
- AwĚZ KZĚ;Ěj ġvĚv ev cwi ġvY, KZĚ; cĚqvĚMi bwxZ, wġgq-Kvġb I KvhĚĚj x mġuġřĚ DĚj wLZ nI qv DvPZ hvĚZ AwĚZ KZĚ;Ěj e`vL`vi e`vcĚĚi msMvĚbi ġġa` mgġġcZv I ġ%ZK` we`gvb \_vĚK|
- KZĚ;AcŕYi wĚKUZg Aa`Ěbi Dci AwĚZ nI qv DvPZ| wĚKUZg Aa`b e`w³ĚK ġwġġ ev wMwĚġq Ab` tKvb e`w³i wĚKU KZĚ;AcŕYi Kiv nĚj D³ wĚKUZg Aa`b e`w³i ġġb ev msMvĚb tĚĚvĚĚi mġo nĚZ cvĚi |





**cvtVĒi gj`iqb: 2**

**A) eū ubePbx cĕæ**

mĭWK DĒi ũbt` Rgj-K Aŋi ũtK eĒvĭqZ Kiab | (D`vniY: Avcbri ubePZ DĒi ũ K ntj GtK **(K)** eĒvĭqZ Kiab)

1. KZĒj:AcP Aaxb`ĕ` i Rb` ũK mĭeav etq Avtb?  
 K. Zv` i `bĭZK gtbvej I AvZĕekĭm eĭx Kti  
 L. Zviv , iaZcP`elq, tj vtZ Mfxi gtbvthvM ũ` tZ cvti  
 M. Zv` i Őviv Kvhrix tbZZj:Mto I tV  
 N. Zviv cāv b cāv , iaZcP`elq i `vĭqZcĕB ntZ cvti |
  
2. tKvbĭU KZĒj:AcP Yi cĕ\_ mĭsMVĭbK cĕZeÜKZv?  
 K. RbMtiYi `ŵi mĭgĕb\_ vKvi tbkv  
 L. Aaxb`ĕ` i cŋ t\_ tK AvbMZ`nxbZvi fq  
 M. mĭsMVtbi ep` vKvi I Ae`rb  
 N. mnthvMx` i Dci Av`ri Afve |
  
3. KLb KZĒj: i `eaZv ũbtq mĭm`vi mĭŵ nq?  
 K. KZĒj:cĕqvtMi bĭvZi Dtj ĩ bv\_ vKtj  
 L. tKvb cĕ` i ũbKU ũK cĭi gY KZĒj:AcP Kiv ntqtQ Zvi Dtj ĩ bv\_ vKtj  
 M. KZĒj:cĕqvtMi Kvheŵvj xi Dtj ĩ bv\_ vKtj  
 N. KZĒj:AcP ũj ũLZfĕte bv ntq\_ vKtj |

**Av) mĭŋŋB DĒi cĕæ**

1. KZĒj:AcP Yi ũkŋŋMZ gj` ej tZ ũK tevSvq?
2. KZĒj:AcP Yi mĭsMVĭbK cĕZeÜKZv, tj v ũK?
3. KZĒj:AcP Yi e`ir<sup>3</sup>MZ cĕZeÜKZv, tj v ũK?
4. KZĒj:AcP Yi KtqKĭU mĭvri Y bĭvZi Dtj ĩ Kiab |



**mĭWK DĒi**

A) 1| K, 2| M, 3|



- 3) `dji bZb uk`JK ubtqum ubqgvbM Kivi Rb` Ges Salary Support c0v`bi Rb` ubtqum m`umKZ ue`AB I Resolution-Gi Kucmn c0qvRbxq KVMRCI gnvcwi Pvj tKi KvQ tc0Y Kiv|
- 4) me aitbi gva`ugK uk`Jv c0Z0vb cwi`k0 Kiv|
- 5) Dc-cwi Pvj tKi ubt`R gZ thme gva`ugK ue`ij q `xKuZ. I Avafie3 i Avte`b Kti Zv cwi`k0 Kiv|
- 6) gva`ugK uk`Jv c0Z0v`bi Dbqbgj-K Kg`mP ev`evqb I ZE`yavb Kiv|

Dch` `vqZi,tjv cvj b Kivi mvt\_ mvt\_ Av`ij K Dc-cwi Pvj K KZR. AucZ temi Kvix `z msµvš`th tKvb `vqZi| tRjv uk`Jv KgRZP cvj b Kti \_v`Kb| tRjv uk`Jv KgRZP `z KZE`JtK `z cwi`tek m`utK`Dct`k-ubt`Rbv c0vb, `dji thvM`Zvm`ubab`bZg msL`K uk`JK I b`bZg uk`JvKiy AvtQ uk`bv tm m`fU tLUR-Lei tbi qv, cix`Jvi djvdj ch`j vPbv Kiv BZ`w `vqZi cvj b Kti \_v`Kb| G cwi`tc0JtZ `z KZE`JtK `vbxq uk`Jv KZE`Ji mvt\_ tmšv`eY`m`uK`i Jv Kti Pj tZ nq|

**`vbxq uk`Jv KZE`J (c0`ugK `fi)**

c0`ugK uk`Jv `fi mivt`tk 481 uU \_v`v uk`Jv Aucdm `vbxq uk`Jv KZE`J intmte KvR Kti \_v`Kb| \_v`v uk`Jv Aucdmvi (TEO) Zui ubR \_v`vi c0`ugK uk`Jvi e`e`vcbv I ZE`yav`bi `vqZi cvj b Kti \_v`Kb| \_v`vi AšMZ mKj c0`ugK ue`ij q`K KZK,tjv K`v`v`i uef3 Kiv nq| mvariYZ GKiu K`v`v`i 20 t`K 30 uU `z AšfZ \_v`K Ges GKRb mnKvix \_v`v uk`Jv Aucdmvi (ATEO) GKiu K`v`v`i i `vqZi; ubtqumRZ \_v`Kb| uzvb c0`ugK uk`Jvi ,YMZ gv`v`v`q`bi j`J` K`v`v`i i AšMZ mKj c0`ugK uk`JtKi c0`JY Kv`h`g cwi`k0 I ZE`yavb Kti \_v`Kb| \_v`v uk`Jv Aucdmv`i i Dci thme KZ`j.I `vqZi;AcP Kiv ntqtQ Zv nj :

- 1) c0`ugK ue`ij qmg`ni cwi`k0 I ZE`yavb Kiv;
- 2) Avqb-e`qb KgRZP intmte KvR Kiv;
- 3) uk`JK I KgPvix`i e`jx, Aemi, tcbkb I Avb`ZvmlK msuk0 c0`te I KVMRCI tRjv c0`ugK uk`Jv Aucdmvi (DPEO)-Gi ubKU tc0Y Kiv;
- 4) Thana Education Committee (TEC)-Gi m`m` miPe intmte KvR Kiv| TEC-Gi um`v`š` tgvZiteK AM0aKvi w`f`E`Z Dbqbgj-K Kv`Ri Rb` c0`ugK ue`ij qmg`ni Zvuj Kv c0`Z Kiv|
- 5) c0`ugK `z m`umKZ hveZxq Z`w` msM0 Kti tRjv c0`ugK uk`Jv `Bti ev Av`Bti tc0Y Kiv;
- 6) thme GjvKvq tKvb `z tbB tmme GjvKvq bZb `z `v`v`bi mgvwi k Kiv;
- 7) uk`JKe`i m`v`f`e`k c0`Z Kiv I nvj bvMv` Kiv|







**cv#VvEi gj`vqb: 3**

**A) eü ubePbx cġæ**

m#K DĒi ubt`Rgj-K Aŋi#K eĚvqZ Kiab | (D`vniY: Avcbvi ubePZ DĒi#K ntj GtK (K) eĚvqZ Kiab)

1. tKvbi#i gva`tg gva`vgK ve`ij q KZĚŋ DaŸZb KZĚtŋi mvt\_ thvMvthvM Kti?
  - K. RvZiq ms`v
  - L. AvĀij K ukŋv`Bi
  - M. tRjv ukŋv`Bi
  - N. \_vbn ukŋv`Bi |
2. ukŋvi gj- KvhĚg tKv\_vq cwi Pvi Z nq?
  - K. ve`ij tŋ
  - L. AvĀ`Bti
  - M. RvZiq ms`vmgŋ
  - N. ukŋv gŸij tŋ |
3. tKvbi# tRjv ukŋv KgRZŋ KvR bq?
  - K. `tŋ i bZb ukŋK ubtŋiMi veĀB gnvcwi Pvj tKi KvQ tcĚY Kiv
  - L. `tŋ i `xKwZ. cĚvb Kiv
  - M. gva`vgK ukŋv cĚZĚtbi cwi`kĚ Kiv
  - N. ukŋKt`i teZtbi mi Kvix AbŸvb m`umKŸ KvMRcĬ cixŋv Kti t`Lv |
4. cĚ\_vgK `ti `vbxq ukŋv KZĚŋ tKvbi#?
  - K. tRjv cĚ\_vgK ukŋv KgRZŋ
  - L. \_vbn ukŋv KgRZŋ
  - M. \_vbn ubePbx KgRZŋ
  - N. mnKvix \_vbn ukŋv KgRZŋ

**Av) ms#ŋB DĒi cġæ**

1. ve`ij tŋi mvt\_ `vbxq ukŋv KZĚtŋi m`utKŋKifc Zv DŋL Kiab |
2. tRjv ukŋv KgRZŋ`i `vqZi | KvhĚj x DŋL Kiab |
3. \_vbn ukŋv KgRZŋ `vqZi | KvhĚj x DŋL Kiab |



**m#K DĒi**

A) 1| M, 2| K, 3| L, 4| L |







teZb I gh®vi w`K w`tq ukŷv wefvMi ubtPi `limgfni c`\_tjvi mvgwMk ckvmb e`e`vq tKvb ,iaZcY®vb tbB| dtj Kvhŷŷt Zuv Dchŷ vb civ bv etj Zt`i weikó fvgKv cvj tbi mŷhvM NtU bv| `fveZB ukŷv ckvmb e`e`vi Dci Gi cŷZKj cŷZdj b NtU|

**O) mgštqi Afie**

ukŷv e`e`vq weifbawefvM Ges GKB wefvMi weifbawefvMi gta` mnthvMZv I mgštqi Afie itqtQ| `ŷ I cwi`k® wefvM Ges Ktj R wefvMi gta` mnthvMZv I mgštqi wefkl tKvb e`e`v tbB| tZgub `ŷ cwi`k® Ges GKB wefvMi weifbawefvMi gta` mnthvMZv I mgštqi Afie itqtQ| `ŷ I cwi`k® GB GKB wefvMi gta` cŷvK I gva`vK `fii gta` mnthvMZv I mgštqi Afie ckvmbK e`e`vi mŷz cwi Pvj bvi cwi cŷt|

**P) ckvmbK cŷŷŷYi Afie**

ukŷv ckvmb e`e`vq Dchŷ cŷŷŷYcŷb thvM` ckvmbK I ckvmb cŷŷŷY e`e`vi Afie itqtQ| eZŷv tbi ukŷv wefvMi ckvmbK tŷŷŷ ubtqvMi Rb` tKvb cŷŷŷYi cŷŷŷY Rb nq bv| ukŷŷŷŷi ŷviv mvaviYZ ckvmbK tŷŷŷ c`\_tjv ciY Kiv nq| GB ukŷŷŷŷi ckvmbK weftq cŷŷŷYi tZgb tKvb e`e`v tbB| Ggb wK ukŷv ckvmb wefvMi ubtPi `fi mivmvi fivte ubtqvM cŷŷŷ KgRZŷ`i I cŷŷŷŷYi tKvb e`e`v tbB| Gi dtj ukŷv ckvmb e`e`vi cŷŷŷ hZuv Kvhŷi cŷŷ MŷY Kiv DvPZ ZZuv Kvhŷi cŷŷ Aej`b Kiv m`e nŷq I tV bv|

**Q) RvZxq ukŷvbwZi Afie**

`vaxbZv jvtfi `xN® b cŷi I tKvb RvZxq ukŷvbwZ cŷŷxZ nqub| RvZxq ukŷvbwZi AeZŷv tbi mgŷq mgŷq ckvmbK Avt`k etj ukŷvbwZ ubawŷi Z nŷq AvmŷQ| GB cŷYzv Avgt`i ukŷv ckvmb e`e`vi GKvU ,iaZcY®vU| RvZxq ukŷvbwZ nŷq hveZxq ukŷv Kgŷŷŷŷi Drmgj-| KvŷRB RvZxq ukŷvbwZi Avtj vŷK hZv`b ukŷv Kvhŷŷŷ cwi Pwŷ Z bv nŷe ZZv`b ukŷv Kvhŷŷŷ avivewKZv I mŷvŷgAm` eRvq ivLv m`e nŷe bv| GUv AZ`ŷŷ Avbŷ`i K\_v th, `xN® tbi cŷŷŷŷŷ RvZxq ukŷvbwZ 1998 mŷtj cŷŷxZ nŷqŷQ| RvZxq msm` KZR.Abŷgŷv Z nI qvi ci GvU kvNB Kvhŷŷŷ nŷe etj Avkv Kiv hvq|

**ckvmb I e`e`vcbvi mŷvŷŷŷK mgm`vej**

Dcwi Dvŷ wLZ mvariY mgm`vej `xN® b aŷi Avgt`i ukŷv ckvmb I e`e`vcbvi tŷŷŷŷ we`gvb itqtQ| mgvŷRi cwi ewZŷ cwi w`vZi mŷ`\_ mvgAm`vxb cvjZb ckvmb e`e`v Pvj y \_vKvi Kvŷŷŷŷ GLb chŷŷŷ Gme mvariY mgm`vi ubimb m`e nqub| mŷvŷŷŷK Kvŷŷŷŷ Avi I bZb wKQymgm`vi D`m`e nŷqŷQ hv cwi w`vZŷŷŷ AvwKZi RvUj Kŷi Zŷŷŷŷ Q| G`\_tjvi ga` t`ŷŷŷŷ Kŷŷŷŷŷ ,iaZcY®mgm`vi K\_v ubtP Dŷŷŷŷ Kiv nj |



**0) ct`vbnzi tŋtĀ` wŋwZv I AmgZv**

eZŋv#b Ktj R ukŋKt`i ct`vbnzi tŋtĀ mgZv iŋv Kiv mæe nt`Q br| KviY eZŋv#b  
welqirfwiEK ct`vbnz cŏvb Kiv nq| dtj cŏZthwMzigj-K weimGm cixŋvi gva'tg GKB  
m½ PKwi#Z thvM`vb Kti tKvb tKvb welŋqi ukŋKMY D³ welŋq c` kb`\_vKvi KviŋY  
ZrovZwo ct`vbnz tctq hv#Qb| cŋvš#i ukQymKQymelŋqi ukŋKMY ct`vbnz cvl qvi  
Rb` meiv`#K thvM` nI qv m#EjI welŋq c` kb` br\_vKvq mivWK mgŋq ct`vbnz cvt`Qb br|  
dtj wZvb Rŋŋqi ntq\_vKtQb| GtZ mgzckvmb I e'e`vcbvi tŋtĀ GK RŋUj Ae`vi  
mŋŋ nt`Q|

**P) Acvi Kiv Zfvte ukŋv cŏZŏvb `vcb**

tKvb cKvi `g` g`mcs Kvhŋg br\_vKvq t`tki weifbæ`v#b bvbwea KviŋY cŏqvR#b I  
AcŏqvR#b ukŋv cŏZŏvb Mto DVtQ hv ukŋv e'e`vcbvi tŋtĀ `bivR` mŋŋ Ki#Q Ges  
ukŋvi I ci A#nZK Pvc evotQ| hTzT we`'ij q Mto I Vvq ukŋvi ,YMZ gvb µgviŋŋq  
wb#Pi w`#K tbtg hv#Q| ukŋv cKvmb I e'e`vcbvi tŋtĀ GuU GKŋU ,iaZcYµŋU|

**Q) vbqšŷ emfZ ukŋv cŏZŏvb**

evsj vt`tki ukŋv e'e`vcbv bivfvte nef³| miKvvi, temiKvvi, `ŋqĒkvmmZ I  
Avav`ŋqĒkvmmZ miKvvi vbqšŷvaxb ukŋv cŏZŏv#bi evBti I e`w³ I tMvŏx gvŋj Kvbvaxb  
weifbæ`#i weifbæat#bi ukŋv cŏZŏvb itq#Q| thgb- ukŐvi Mv#UŦ, BstivR gva'g I-  
tj#fj Ges G-tj#fj ukŋv cŏZŏvb, wŋK`v#WU, tKvPs tm#Uvi BZ`w` hv`i I ci  
miKv#i tZgb tKvb KZŋj.tbB| ukŋvi cKvmmB tŋtĀ bvbwea RŋUj Zv mŋŋi cikvcvŋk  
Gme cŏZŏvb GKŋU mgZwfwĒK RvZxq ukŋv e'e`v Mto tZvj vi ct`\_ cŏZeÜKZvi mŋŋ  
Ki#Q|





**ci#VvEi gj`vqb: 1**

**A) msu#B DEi c#æ**

1. uk#v c#vmbi t#t# #gZv, `vqZ; I KZ#; i vRavb#Z tK#`KiY Kiv ntqtQ-  
K\_vuJ e`vL`v Kiab|
2. uk#vbmZi t#t# uk#vme`#`i g#Zi c#vb` t`qv D#PZ tKb?
3. c#vmb i #Ykxj g#bvfve t`Lv t`q tKb?
4. Avcbvi g#Z uk#v c#vmb I e`e`vcbvi t#t# m#u#ZK Kv#j i #ZbuJ c#vb  
mgm`v D#j L Kiab|

**Av) iPbvgj-K c#æ**

1. evsj v#`#ki uk#v c#vmb I e`e`vcbvi mvavi Y mgm`v, #j v uK?
2. uk#v c#vmb I e`e`vcbvi t#t# m#u#Z D#m#Z mgm`v, #j v e`vL`v Kiab|





**3. KvRi clyivej I Kvj t`qcy tiva KitZ nte**

t`tki eZgvb uk`qv e`vcbv I ckvmtbi wevfbae`Bti i gta` tZgb tKvb mgstqi e`v  
tbB| uk`qv gsjyjq I uk`qv cwi`Bi GKB KvRi clyivejEmn GKwaK ms`vq GKB  
KvRi clyivejEi`0Z I wdgjx e`vcbvi dtj Kvj t`qcmn ckvmtb `weiZvi mjo  
ntqtQ| dtj `vqexZv uk`v\_j nt`Q Ges Reven`wZv tjvc cvt`Q|

**4. cwi`k0 e`vi AvapKvKiY KitZ nte**

cwi`k0 e`vi eZgvb KvVtgv GKwU mgwSZ KgmuPi AvI Zvq Gtb GK avivi ckvmtbK  
I GKvWngK cwi`k0 KvVtgv MVb Kti AvAjij K, tRjv I \_vbi chSf m`u`vni Z Kiv  
`iKvi| G KvR mnvqZv `v`bi j`q` Avab`Bti eZgvb EMIS Kv`uDUvi tmj`K  
m`u`viY Kti AvapKvKiY Kiv c0qvRb| c0Z0vmbK Z\_`w` msi`q`Yi e`v wboZ  
Kti wixqv I cixqv Kiv mnRZi Kiv thtZ cvti| GQvor `z, Ktj R I gv`v`vvi  
uk`qv Kvhpq I cwiexqv KvR mnvqZv `v`bi Rb` Kv`uDUvii e`envi wboZ Kiv  
c0qvRb|

**5. ckvmb I e`vcbvq uk`vme`t`i m`u`3 KitZ nte**

`z I Ktj R chiqi uk`vvi m`z RwoZ uk`vme`t`i e`vcbvq Avak nvti m`u`3  
KitZ nte| tgav, `qv I AvfAZvi wfiEtZ c0k`q`Yi gva`tg wbePZ e`v`t`i uk`v  
ckvmtb w`h` Kiv thtZ cvti| uk`v K`wv`ti thvM`Zv I AvfAZv Abjvq me`ti  
c`v`q`bi Rb` wetePZ nI qvi m`h`vM \_vKtZ nte|

**6. uk`v ckvmt`i c0k`q`Y c0v`bi e`v M0Y KitZ nte**

uk`v wfv`Mi Avdmv`t`i ckvmtbK c` wbtqvRZ Kivi c`e`c0k`q`Y c0vb KitZ nte|  
e`Zc`q` uk`vvi mKj `ti uk`v KgRZ`i ckvmtbK c` wbtqv`Mi Ae`wnZ cti Ges  
c`v`biZi c`e`uk`v ckvmb I e`vcbv w`l`qi c0qvRbxq c0k`q`Y c0v`bi wbgg Kiv  
m0z`uk`v ckvmb e`v Mto tZvjvi Ab`Zg ceRZ` `z`i c0vb uk`vK, Aa`q,  
cwi`kR, w`kIA Ges KgRZ`i ckvmtbK I tckvMZ `qvZvi DrKI`eavbKt` wvfbae  
tgqv`x c0k`q`Y tKv`AvtqvR`bi Dci \_iaZj` I qv c0qvRb|

**7. miKvvi I temiKvvi uk`v c0Z0v`bi gta` `elg` vbimb KitZ nte**

t`tki uk`v e`vq miKvvi I temiKvvi GB `v aviv itqtQ| miKvvi uk`v c0Z0v`bi  
gZ temiKvvi uk`v c0Z0v`bi uk`vK wbtqv`Mi Rb` GKwU wbtqvM wewa I m0z`vniZgvjv  
\_vKv evAbxq| G Qvor `z g`v`b`Rs KvgwU Ges Mfwb`eww MVb I Zv`i `q`Zvi h\_vh\_  
e`envi wboZ Kivi Rb` m`p`wSZ bniZgvjv \_vKv evAbxq| miKvvi I `v`E`kvmmZ uk`v  
c0Z0v`bi m`z temiKvvi uk`v c0Z0v`bi uk`vK I KgPvixi teZb `elg` GLbl  
weivRgvb| ZvQvor G mKj c0Z0v`bi gta` QvT teZ`bi I e`vck ZviZg` itqtQ| G  
mKj `elg` `i Kiv c0qvRb Ges miKvvi I temiKvvi c0Z0v`bi QvT-QvT`i Avfbae



